

VISUALIZZAZIONE	DESCRIZIONE	SOLUZIONE
Il display visualizza Err7	Errore encoder	Verificare il collegamento dell'encoder
Il display visualizza Err8	Quando si cerca di eseguire una funzione di autoapprendimento il comando viene rifiutato. Significa che l'impostazione della centrale non è compatibile con la funzione richiesta.	<ol style="list-style-type: none"> 1. Verificare che gli ingressi di Start siano abilitati in modalità standard (menù Start impostato su Start) 2. Verificare che l'interfaccia ADI sia disabilitata (menù ADI impostato su no).
Il display visualizza Err9	Significa che la programmazione è stata bloccata con la chiave di blocco programmazione CL512K (codice 161266).	Per procedere con la modifica delle impostazioni è necessario inserire nel connettore interfaccia ADI 2.0 la stessa chiave usata per attivare il blocco programmazione e sbloccarla.
Il display visualizza Err10	Quando viene dato un comando di start il cancello non si apre. Significa che è fallito il test di funzionamento dei moduli ADI.	<ol style="list-style-type: none"> 1. Verificare che il modulo ADI sia inserito correttamente 2. Verificare che il modulo ADI non sia danneggiato e funzioni correttamente
Il display visualizza Err11	Quando viene dato un comando di start il cancello non si apre. Significa che è stato rilevato un malfunzionamento dei motori	Verificare i collegamenti del motore.
Il display visualizza Err12	Quando viene dato un comando di start il cancello non si apre. Significa che è stato rilevato un surriscaldamento del motore	Il sistema tornerà a funzionare normalmente appena il motore si sarà raffreddato. Se il problema si ripresenta contattare il servizio di assistenza tecnica V2
Il display visualizza Err13	Il circuito di autodiagnosi ha rilevato un malfunzionamento che impedisce il funzionamento sicuro dell'automazione	Contattare il servizio di assistenza tecnica V2 per inviare la centrale in riparazione
Il display visualizza Err14	Il circuito di autodiagnosi ha rilevato un errore nella tabella dei parametri di configurazione	Entrare nel menù di configurazione, verificare attentamente tutti i parametri e correggere gli eventuali errori. Se l'errore persiste contattare il servizio di assistenza tecnica V2 per inviare la centrale in riparazione
Il display visualizza Err15	Il limite del ciclo di lavoro è stato superato	La centrale tornerà a funzionare regolarmente dopo una pausa forzata. In questa situazione è possibile comunque attivare l'automazione in modalità FUNZIONAMENTO A UOMO PRESENTE D'EMERGENZA (capitolo 10)

INDEX

1 - IMPORTANT REMARKS	30
2 - DISPOSAL	30
3 - EU DECLARATION OF CONFORMITY	30
4 - TECHNICAL SPECIFICATIONS	31
5 - DESCRIPTION OF THE CONTROL UNIT	31
5.1 - ELECTRIC CONNECTIONS.....	32
5.2 - MOTORS.....	34
5.3 - STOP.....	34
5.4 - ACTIVATION INPUTS.....	35
5.5 - PHOTOCELLS.....	36
5.6 - SAFETY EDGES.....	36
5.7 - LIMIT SWITCHES AND ENCODER.....	37
5.8 - LOW VOLTAGE LIGHT (24V).....	38
5.9 - COURTESY LIGHT.....	38
5.10 - LOCK.....	39
5.11 - EXTERNAL AERIAL.....	39
5.12 - POWER SUPPLY.....	39
6 - PLUG IN RECEIVER	40
7 - ADI INTERFACE	40
8 - CONTROL PANEL	40
8.1 - USE OF THE DOWN, MENU AND UP KEYS FOR PROGRAMMING.....	41
9 - QUICK CONFIGURATION	42
10 - LOADING DEFAULT PARAMETERS	42
11 - SELF-LEARNING OF WORKING TIMES	43
12 - EMERGENCY DEAD MAN OPERATION	44
13 - READING THE COUNTER OF THE CYCLES AND EVENTS MEMORY	44
14 - CONTROL UNIT CONFIGURATION	46
15 - OPERATION DEFECTS	54

1 - IMPORTANT REMARKS

For any installation problem please contact our Customer Service at the number +39-0172.812411 operating Monday to Friday from 8:30 to 12:30 and from 14:00 to 18:00.

V2 has the right to modify the product without previous notice; it also declines any responsibility to damage or injury to people or things caused by improper use or wrong installation.

 **Please read this instruction manual very carefully before installing and programming your control unit.**

- This instruction manual is only for qualified technicians, who specialize in installations and automations.
- The contents of this instruction manual do not concern the end user.
- Every programming and/or every maintenance service should be done only by qualified technicians.

AUTOMATION MUST BE IMPLEMENTED IN COMPLIANCE WITH THE EUROPEAN REGULATIONS IN FORCE:

EN 60204-1 (Machinery safety, electrical equipment of machines, part 1: general rules)

EN 12453 (Safe use of automated locking devices, test methods, requirements)

- The installer must provide for a device (es. magnetothermal switch) ensuring the omnipolar sectioning of the equipment from the power supply. The standards require a separation of the contacts of at least 3 mm in each pole (EN 60335-1).
- After making connections on the terminal board, use one hose clamp to fix dangerous voltage wires near the terminal board and another hose clamp to fix safety low voltage wires used for accessories connection; this way, in case of accidental detachment of a conducting wire, dangerous voltage parts will not come into contact with safety low voltage ones.
- The plastic case has an IP55 insulation; to connect flexible or rigid pipes, use pipefittings having the same insulation level.
- Installation requires mechanical and electrical skills, therefore it shall be carried out by qualified personnel only, who can issue the Compliance Certificate concerning the whole installation (EEC Directive 2006/42/CE, Annex IIA).
- The automated vehicular gates shall comply with the following rules: EN 12453, EN 12978 as well as any local rule in force.
- Also the automation upstream electric system shall comply with the laws and rules in force and be carried out workmanlike.
- The door thrust force adjustment shall be measured by means of a proper tool and adjusted according to the max. limits, which EN 12453 allows.
- We recommend to make use of an emergency button, to be installed by the automation (connected to the control unit STOP input) so that the gate may be immediately stopped in case of danger.
- Always remember to connect the earth according to current standards (EN 60335-1, EN 60204-1).



2 - DISPOSAL

As for the installation operations, even at the end of this product's life span, the dismantling operations must be carried out by qualified experts.

This product is made up of various types of materials: some can be recycled while others need to be disposed of.

Find out about the recycling or disposal systems envisaged by your local regulations for this product category.

Important! – Parts of the product could contain pollutants or hazardous substances which, if released into the environment, could cause harmful effects to the environment itself as well as to human health.

As indicated by the symbol opposite, throwing away this product as domestic waste is strictly forbidden. So dispose of it as differentiated waste, in accordance with your local regulations, or return the product to the retailer when you purchase a new equivalent product.

Important! – the local applicable regulations may envisage heavy sanctions in the event of illegal disposal of this product.

3 - EU DECLARATION OF CONFORMITY

The manufacturer V2 S.p.A., headquarters in Corso Principi di Piemonte 65, 12035, Racconigi (CN), Italy

Under its sole responsibility hereby declares that the products: **CX EVO2**

comply with the following directives:

- 2014/30/UE (EMC Directive)
- 2014/35/UE (Low Voltage Directive)
- RoHS-3 2017/2102

Furthermore, the product complies with the following standards:

EN IEC 61000-6-2:2019, EN IEC 61000-6-3:2021
IEC 60335-1:2020

Racconigi, 01/03/2024

V2 S.p.A. legal representative.

Roberto Rossi

4 - TECHNICAL SPECIFICATIONS

	CX EVO2	CX EVO2 SP
Power supply	230V / 50Hz	K ECO-24
Maximum load consumed from the mains with two motors + accessories	250W	250W
Nominal load for each motor output	80W	80W
Max accessories load 24Vdc (terminals L6-L7, L8-L7)	12W	12W
Work cycle (*)	80%	80%
Protection fuse	2,5A	-
Weight	3000 g	1000 g
Dimensions	312 x 210 x 100 mm	
Working temperature	-20 ÷ +60°C	
Protection	IP55	

	CX EVO2 120V
Power supply	120V / 50-60Hz
Maximum load consumed from the mains with two motors + accessories	250W
Nominal load for each motor output	80W
Max accessories load 24Vdc (terminals L6-L7, L8-L7)	12W
Work cycle (*)	80%
Protection fuse	2,5A
Weight	3000 g
Dimensions	312 x 210 x 100 mm
Working temperature	-20 ÷ +60°C
Protection	IP55

(*) the work cycle is related to the following conditions:

2 motors @ nominal load

Room temperature = 25°C

5 - DESCRIPTION OF THE CONTROL UNIT

CX EVO2 is provided with a display that, not only makes programming simple, but also allows a continuous monitoring of the input statuses; in addition, thanks to a menu structure, the working schedule and the operation logic can be set easily.

In compliance with the European standards concerning electrical safety and electromagnetic compatibility (EN 60335-1, EN 50081-1 and EN 50082-1) it has been equipped with the low voltage circuit total electric insulation (motors included) from the network voltage.

Other characteristics:

- Power supply protected from short circuits within the controller, on the motors and on the connected accessories
- Adjustment of the power by partializing the current
- Detecting obstacles by monitoring the current on the motors (current sensing probe)
- Automatic learning of the operation time.
- Tests for safety devices (photocells, safety ribbons and mosfet) before each opening.
- Deactivation of safety inputs through the configuration menu: no jumper is required for terminals concerning safety devices that have not been installed, yet. You will only need to disable this function from its relevant menu.
- The device can operate without mains power, by using the optional battery pack (code 16Y016).
- Low voltage output that can be used for a signal light or a 24 V flashing light.
- Auxiliary relay with programmable logic for courtesy light, flashing light or other use.
- Automatic shutdown of all peripherals when the control unit is not operating the gate, to keep the power absorbed in stand-by below 500 mW.

5.1 - ELECTRIC CONNECTIONS

 **WARNING: The installation of the unit, safety devices and accessories must be carried out when the power supply is disconnected**

BEFORE PROCEEDING WITH THE ELECTRICAL CONNECTIONS, READ CAREFULLY THE CHAPTERS DEDICATED TO THE INDIVIDUAL DEVICES AVAILABLE IN THE PAGES THAT FOLLOW.

A1	Antenna shield
A2	Antenna

J1	Opening control for the connection of control devices with N.O. contact
J2	Opening controls for pedestrian access for the connection of control devices with N.O. contact
J3	24Vdc power supply for activation devices available even when the control unit is in stand-by (24V ± 15% / 3W)
J4	Common (-)
J5	FOT1 - Photocells type 1. N.C. contact
J6	FOT2 - Photocells type 2. N.C. contact
J7	COS1 - Safety edges type 1. N.C. contact
J8	COS2 - Safety edges type 2. N.C. contact
J9	Common (-)

L1	Open limit switch motor 1	Encoder motor 2
L2	Close limit switch motor 1	
L3	Open limit switch motor 2	Encoder motor 1
L4	Close limit switch motor 2	
L5	Common (-)	
L6	24 Vdc power output for photocells and other accessories which are turned off during stand-by	
L7	Common for accessories power supply	
L8	Photocell/optical edge TX power supply for functional test	
L9-L10	LOCK 12V	
L10-L11	Low voltage light (24V - 10W)	

E1	Motor 1 (OPENING)
E2	Motor 1 (CLOSING)
E3	Motor 2 (OPENING)
E4	Motor 2 (CLOSING)
E5	GROUND

B1 - B2	230VAC courtesy light or flashing light
----------------	---

L	Power phase 230V/120V
N	Neutral 230V/120V

BATTERY	Connector for buffer battery or solar panel
RM	Plug in receiver
ADI	ADI interface
OVERLOAD	It shows that there is an overload on accessories power supply
MAINS	It shows that the control unit is power supplied
F1	2,5 A

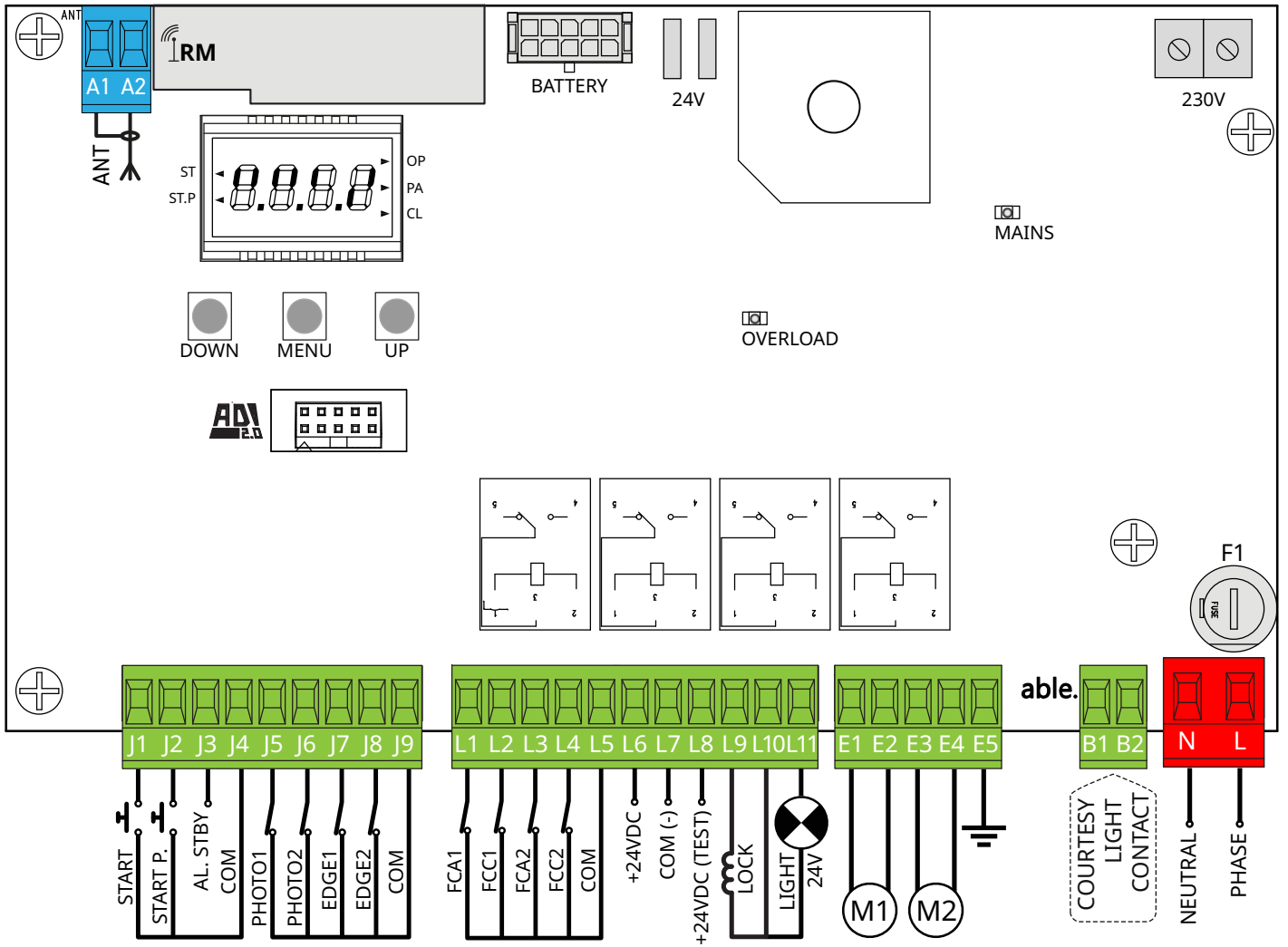

6.2 - MOTORS

CX EVO2 control unit can control one or two 24V motors.

If the control unit must control only one motor, this must be connected to the terminals relating to motor 1 and the P0L2 parameter must be set to no.

Connect motor 1 cables as follows:

- opening cable to terminal **E1**
- closing cable to terminal **E2**

Connect motor 2 (if any) cables as follows:

- opening cable to terminal **E3**
- closing cable to terminal **E4**

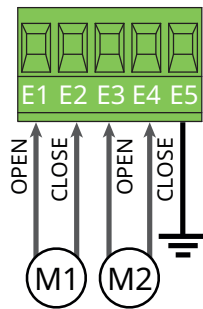

⚠ PLEASE NOTE: to avoid interference between the motor and the photocells, it is essential to connect both the motor casing and the control unit frame to the electrical system ground.

5.3 - STOP

For a better safety, you can fit a stop switch that will cause the immediate gate stop when activated.

This switch must have a normally close contact that will get open in case of operation.

In case the stop switch is operated while the gate is open, the automatic closing function will always be disabled. To close the gate again, you will need a start command.

The stop switch shares the input terminal with the sensitive edges; if you use this switch you must give up one of the two types of sensitive edges.

Connect the STOP switch cables between terminals **J7** (or **J8**) and **J9** of the control unit.

ATTENTION! If terminal **J7** or **J8** is used for a stop command, the control unit always considers it a normally closed input, regardless of the parameter setting C0.5E.

The STOP switch function can be activated by means of a remote control stored on channel 3 of MR receiver.

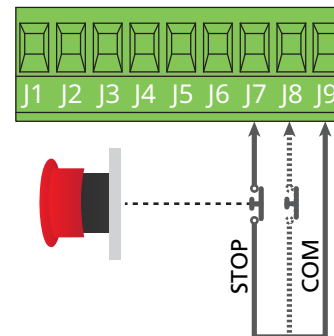

5.4 - ACTIVATION INPUTS

CX EVO2 control unit is equipped with two activation inputs (START and START P.), whose operation depends on the programmed operation modes (see **Start** item of programming menu):

Standard mode

START = START (a command will cause the complete opening of the gate)

START P. = PEDESTRIAN START (a command will cause the partial opening of the gate)

Open/Close command

START = OPENING (always controls the gate opening)

START P. = CLOSING (always controls the gate closing)

This is an impulse command, that is to say that an impulse will cause the complete gate opening or closing.

Manned operation

START = OPENING (always controls the gate opening)

START P. = CLOSING (always controls the gate closing)

This is a monostable command, that is to say, the gate will be opened or closed as long as the contact is closed and it will immediately stop as the contact is open

Mode with presence or fire sensor

In this mode, the PEDESTRIAN START input can be used to connect a maintained command device, such as a presence detector, a magnetic loop or a fire sensor.

Closing the contact causes the gate to open immediately and completely (or reopen if the gate is closing), and closing is no longer possible until the contact opens.

Depending on the option chosen in the **Start** menu, you can have normal operation, suitable for presence detectors, or emergency operation, for the fire sensor; in the first case, the opening is subject to all the controls of a normal opening, and if automatic re-closing is programmed, when the contact reopens the gate closes automatically; in the second case only the checks that could have consequences on safety are carried out, and a start command is necessary to close the gate once the alarm is over.

In both modes, the START input starts the cycle as in standard mode.

ATTENTION! If the device that controls the opening must be powered by the control unit, terminal J3 (+24V) and J4 (COM) must be used, so that the power supply is available even when the control unit is in stand-by.

Timer mode

This feature allows you to program time slots during the day for the gate to be open by using an external timer or other maintained command devices (e.g. magnetic loop detectors or presence detectors).

START = START (a command will cause the complete opening of the gate)

START P. = PEDESTRIAN START (a command will cause the partial opening of the gate)

The gate stays open (completely or partially) while the contact is closed on input; as soon as the contact is open the pause time count down will start, after which the gate will be closed again.

ATTENTION: Automatic closing must be enabled

NOTE: If the parameter **P.RPP = 0** the timer connected to START P. does not cause the opening, but can inhibit the automatic closing at preset times.

In all modes, inputs must be connected to devices having normally open contacts.

Connect cables of device controlling the START input between terminals **J1** (START) and **J4** (COM) of the control unit.

Connect cables of device controlling the START P. input between terminals **J2** (START P.) and **J4** (COM) of the control unit.

The START input function can also be activated by pressing UP key (outside the programming menu) or by means of a remote control stored on channel 1 of MR receiver.

The START P. input function can also be activated by pressing DOWN key (outside the programming menu) or by means of a remote control stored on channel 2 of MR receiver.

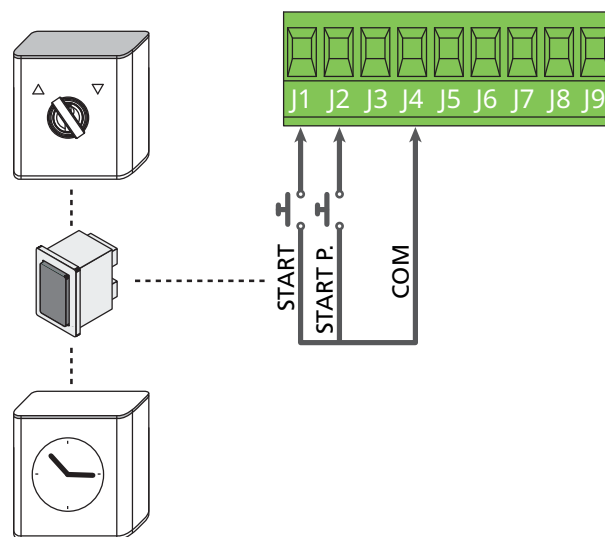

5.5 - PHOTOCELLS

The control unit considers two kinds of photocells, depending on the terminal to which they are connected:

Photocell 1

Photocells installed on the gate inner side, which are active both during the opening and the closing phase. When photocells 1 operate, the control unit stops the gate; as soon as the photocell beam is free, the control unit will open the gate completely.

⚠ WARNING: Type 1 photocells must be installed so that they completely cover the opening area of the gate.

Photocell 2

Photocells installed on the external gate side and which are active during the closing phase only. When photocells 2 operate, the control unit opens the gate immediately, without waiting for release.

CX EVO2 control unit supplies a 24Vdc power supply to photocells and it can perform a photocell operation test before starting the gate opening phase. Photocell power terminals are protected by an electronic fuse that stops current in case of overload.

⚠ PLEASE NOTE: it is recommended that the cable ducts used for the motor cables NOT BE USED for the cables connecting the photocells.

- Connect power supply cables of photocells transmitter between terminals **L7 (-)** and **L8 (+Test)** of the control unit.
- Connect power supply cables of photocells receiver between terminals **L6 (+)** and **L7 (-)** of the control unit.
- Connect receiver output of photocells 1 between terminals **J5 (PHOTO1)** and **J9 (COM)** of the control unit and receiver output of photocells 2 between terminals **J6 (PHOTO2)** and **J9 (COM)** of the control unit.
Use outputs having normally closed contact.

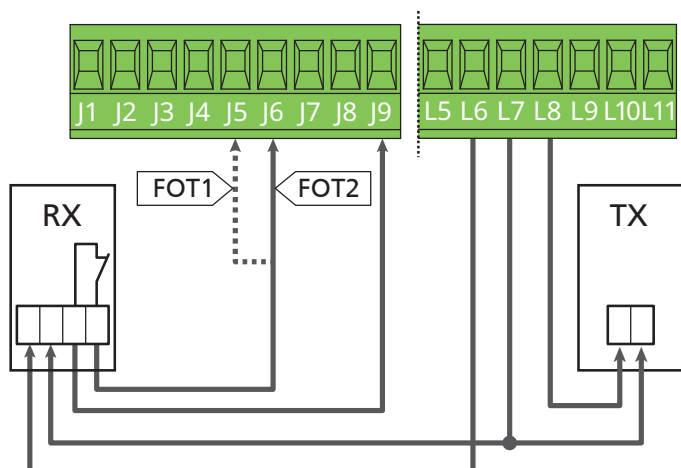

⚠ WARNING:

- if several couples of same kind photocells are mounted, their outputs must be connected in series.
- In case of reflection photocells, power supply must be connected to terminals **L7 (-)** and **L8 (+Test)** of the control unit to carry out the operation test.

5.6 - SAFETY RIBBONS

The control unit considers two kinds of safety ribbons, depending on the terminal to which they are connected:

Type 1 (fixed)

They are mounted on walls or on other fixed obstacles that are approached by the gate doors during the opening phase. When type 1 safety ribbons operate during the gate opening phase, the control unit will close the doors for 3 seconds, then it stands still; when type 1 safety ribbons operate during the gate closing phase, the control unit will stand still immediately. The direction of the gate at next command of START or PEDESTRIAN START depends upon the parameter STOP (it inverts or continues the motion).

If the input STOP is disabled, the command makes the motion continue in the same direction. If the STOP input is disabled, the control restarts motion in the same direction it was travelling prior to the intervention of the edge.

Type 2 (mobile)

They are mounted to the door ends.

When type 2 safety ribbons operate during the gate opening phase, the control unit will stand still immediately; when type 2 safety ribbons operate during the gate closing, the control unit will open the doors for 3 seconds, then it will stand still. The direction of the gate at next command of START or PEDESTRIAN START depends upon the parameter STOP (it inverts or continues the motion). If the input STOP is disabled, the command makes the motion continue in the same direction.

If the STOP input is disabled, the control restarts motion in the same direction it was travelling prior to the intervention of the edge.

Both the input can manage the classic safety edge with n.c. contact and the conductive rubber safety edge with 8,2 kohm nominal resistance.

Connect type 1 safety ribbons cables between terminals **J7 (EDGE1)** and **J9 (COM)** of the control unit.

Connect type 2 safety ribbons cables between terminals **J8 (EDGE2)** and **J9 (COM)** of the control unit.

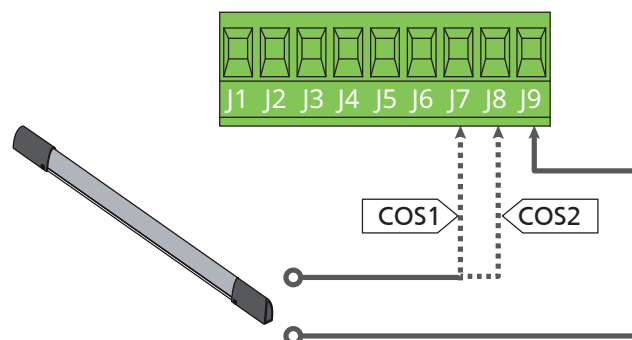

In order to meet the requirements of the EN12978 rules, it is necessary to install safety edges controlled by a control unit continuously checking the proper working. If using control units suited to the test by power outage, connect the power supply cables of the control unit between terminals **L7 (-)** and **L8 (+Test)** of the control unit.

Otherwise, connect them between terminals **L6 (+)** and **L7 (-)**.

⚠ WARNING:

- Make use of safety ribbons having outputs with normally close contact.
- Outputs of same kind safety ribbons must be connected in series.

5.7 - LIMIT SWITCH AND ENCODER

The CX EVO2 controller can control the gate's travel using a limit switch and/or an encoder.

⚠ CAUTION: The use of these devices is recommended to ensure that the gate opens and closes correctly.

The speed of operation of the DC motors can be conditioned by variations in mains power, atmospheric conditions, and friction of the gate. Furthermore, encoders also allow the controller to determine if the gate stops in an irregular position due to an obstacle.

For encoder operation, it is required that the closure position for each section of the gate be detectable using a limit switch sensor or a mechanical stop.

Each time the controller is turned on, to realign the encoders, the gate is closed until it reaches the limit switch or the mechanical stop.

The control unit supports two kinds of end of stroke:

- end of stroke equipped with a normally close switch that will be opened as soon as the door reaches its position desired (set the parameter $FC.En = L.S'W'$)
- end of stroke in series of motor winding (set the parameter $FC.En = Cor.O$)

GATES WITH TWO PANELS

For gates with two panels, limit switches and encoders share the same terminals so it is not possible to install both of these devices at the same time.

⚠ PLEASE NOTE: refer to the motor manual

Installation of limit switch

- Connect the open limit switch to motor 1 using terminals **L1 (FCA1)** and **L5 (COM)**
- Connect the close limit switch to motor 1 using terminals **L2 (FCC1)** and **L5 (COM)**

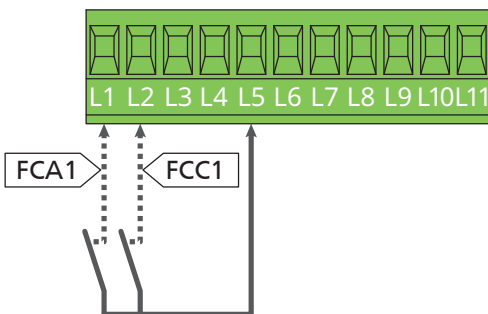

- Connect the open limit switch to motor 2 using terminals **L3 (FCA2)** and **L5 (COM)**
- Connect the close limit switch to motor 2 using terminals **L4 (FCC2)** and **L5 (COM)**

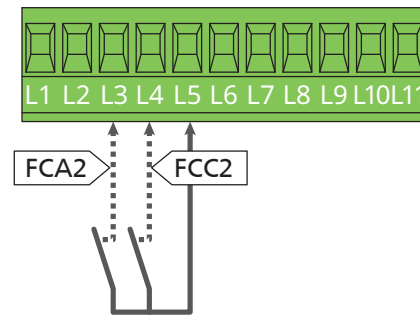

Installation of encoders

- Connect the negative power supply of both encoders to terminal **L5 (COM)**
- Connect the positive power supply of both encoders to terminal **L6 (+)**

If the encoder has 2 channels

- Connect the encoder outputs of motor 1 to the terminals **L3 (FCA2)** and **L4 (FCC2)**
- Connect the encoder outputs of motor 2 to the terminals **L1 (FCA1)** and **L2 (FCC1)**

If the encoder has 1 channel

- Connect the encoder output of motor 1 to the terminal **L3 (FCA2)**
- Connect the encoder output of motor 2 to the terminal **L4 (FCC2)**

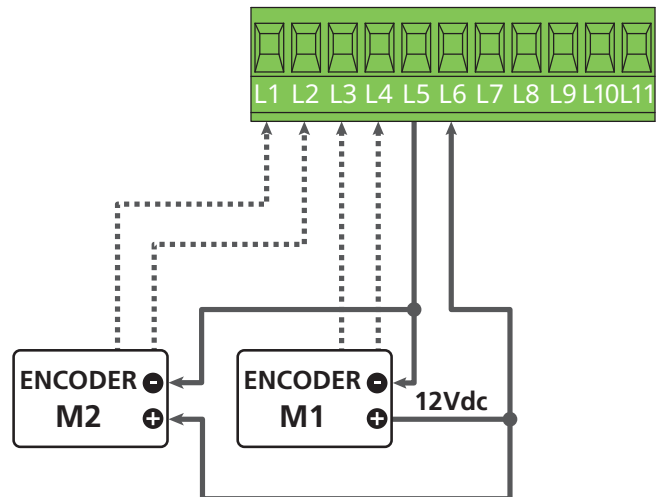

⚠ Check that the two pairs of wires have been correctly connected and after installation proceed as follows:

1. Disable encoder operation (Enco menu)
2. Set a meaningful open delay (r.RP menu)

NOTE: The default settings in the controller satisfy points 1 and 2.

3. Give a START command:
 - If both gate panels move, the wires are connected correctly
 - If **Err1** appears on the display once panel 1 starts to move, invert the wires connected to terminals **L3 (FCA2)** and **L4 (FCC2)**
 - If **Err1** appears on the display once panel 2 starts to move, invert the wires connected to terminals **L1 (FCA1)** and **L2 (FCC1)**

GATES WITH SINGLE PANELS

Installation of limit switch

- Connect the open limit switch to terminals **L1 (FCA1)** and **L5 (COM)**
- Connect the close limit switch to terminals **L2 (FCC1)** and **L5 (COM)**

Installation of encoder

- Connect the negative feeds to terminal **L5 (COM)**
- Connect the positive feeds to terminal **L6 (+)**

If the encoder has 2 channels

- Connect the encoder outputs to the terminals **L3 (FCA2)** and **L4 (FCC2)**

If the encoder has 1 channel

- Connect the encoder output to terminal **L3 (FCA2)**

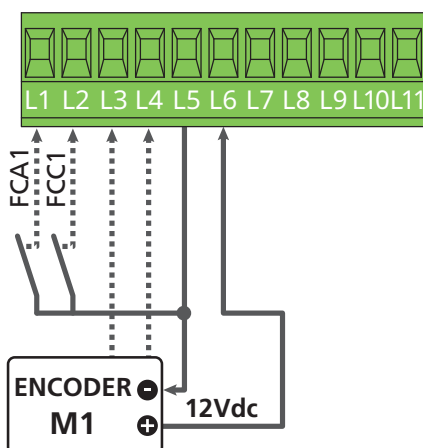

Check that the two encoder wires have been correctly connected and after installation proceed as follows:

1. Disable encoder operation (Enco menu)
2. Give a START command:
 - If the gate moves, the wires are connected correctly
 - If **Err1** appears on the display once the gate starts to move, invert the wires connected to terminals **L3 (FCA2)** and **L4 (FCC2)**

5.8 - LOW VOLTAGE LIGHT (24V)

The CX EVO2 controller has a 24 V DC output that allows connections to a load up to 10 W. This output can be used to connect a signal light that indicates that status of the gate, or for a low voltage flashing light.

Connect the low voltage signal light or flashing light wires to terminals **L10 (+)** and **L11 (-)**.

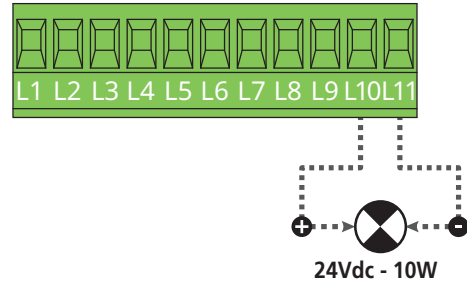

⚠ CAUTION: Pay attention to the polarity of the connected device if necessary.

5.9 - COURTESY LIGHT

Thanks to the output COURTESY LIGHT the control unit allows the connection of an electric appliance (e.g. courtesy light or garden lights), controlled automatically or by means of the special transmitter key.

CAUTION: When the controller is operating on battery power, the 230 V flashing light will not work.

The output COURTESY LIGHT is a simple N.O. contact with no power supply (the maximum rating of the relay is 5A - 230V).

Connect the cables to terminals **B1** and **B2**.



Example for connecting a 230V light

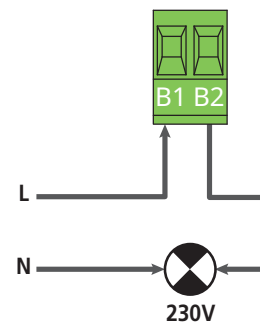

5.10 - LOCK

An electric lock can be assembled on the gate, to ensure a good closing of doors. Make use of a 12V lock.

Connect lock cables to terminals **L9** and **L10** of the control unit.

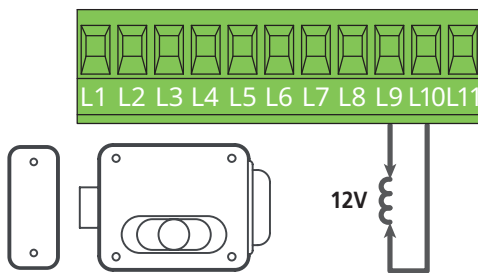

5.11 - EXTERNAL AERIAL

We suggest to use the external aerial (model: ANS433) in order to guarantee the maximal range.

Connect the antenna hot pole to terminal **A2 (ANT)** of the control unit and the braiding to terminal **A1 (ANT-)**.

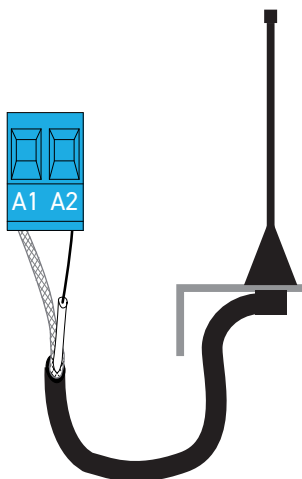

5.12 - POWER SUPPLY

The control unit must be fed by a 230V - 50Hz (120V - 50/60Hz for 120V model) electric line, protected by a differential magnetothermal switch complying with the law provisions in force.

Connect power supply cables to terminals **L** and **N**.

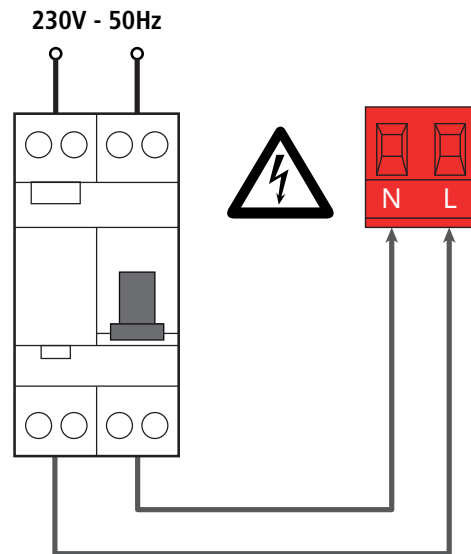

6 - PLUG IN RECEIVER

CX EVO2 control unit is suitable for plugging in a MR receiver.

⚠ WARNING: Pay attention to the way you connect the removable modules.

MR module receiver is provided with 4 channels and each of them is suitable for a command of CX EVO2 control unit:

- CHANNEL 1 → START
- CHANNEL 2 → PEDESTRIAN START
- CHANNEL 3 → STOP
- CHANNEL 4 → COURTESY LIGHT

⚠ WARNING: Before programming 4 channels and function logics read carefully the instructions of MR.

7 - ADI INTERFACE

The ADI (Additional Devices Interface) interface of the control unit CX EVO2 allows the connection to V2 optional modules.

Refer to V2 catalogue or to the technical sheets to see which optional modules with ADI interface are available for this control unit.

⚠ WARNING: Please read the instructions of each single module to install the optional modules.

For some devices, it is possible to configure the mode for interfacing with the control unit; in addition, it is necessary to enable the interface so that the control unit can process the signals arriving from the ADI device.

Please refer to the **1. Ad** programming menu to enable the ADI interface and access the device configuration menu.

The ADI device can signal photocell, edge or stop alarms:

- **Photocell alarms** - the gate stops moving, when the alarm stops opening restarts.
- **Edge alarm** - inverts motion of the gate for 3 seconds.
- **Stop alarm** - the gate stops and cannot restart until the alarm stops.

8 - CONTROL PANEL

When power is on, the control unit checks that display correctly operates by switching on all segments for 1 sec. **8.8.8.8.**

In the next second, the **C.E. 2** model is indicated.

Firmware version, e.g. **Pr 1.0**, will be viewed in the following 2 sec.

Panel will be viewed upon completion of this test.

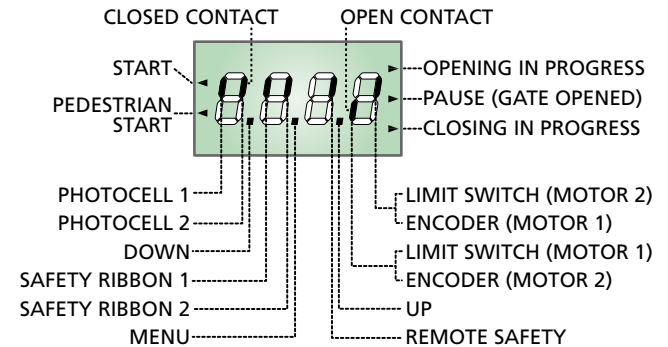

The control panel represents the physical status of the terminal board contacts and of the program mode keys: if the upper vertical segment is on, the contact is closed; if the lower vertical segment is on, the contact is open (the above picture shows an instance where the inputs LIMIT SWITCH, PHOTOCELL 1, PHOTOCELL 2, SAFETY RIBBONS 1, SAFETY RIBBONS 2 and STOP have all been correctly connected).

The segments indicated as REMOTE SAFETY show the status of the remote safety devices for the device connected to the ADI connector.

- If the ADI interface is not enabled (no device connected), both segments remain turned off.
- If the device indicates a photocell alarm, the upper segment comes on.
- If the device indicates an edge alarm, the lower segment comes on.
- If the device indicates a stop alarm, both segments start flashing.

Points being among display digits show the status of programming push-buttons: as soon as a push-button is pressed, its relevant point turns on.

The arrows on the left of the display show the state of the start inputs. The arrows light when the related input is closed.

The arrows on the display right side show the gate status:

- The highest arrow turns on when the gate is into its opening phase. If it blinks, it means that the opening has been caused by a safety device (border or obstacle detector).
- The central arrow shows that the gate is on pause. If it blinks, it means that the time countdown for the automatic closing has been activated.
- The lowest arrow blinks when the gate is into its closing phase. If it blinks, it means that the closing has been caused by a safety device (border or obstacle detector).

8.1 - USE OF THE DOWN, MENU AND UP KEYS FOR PROGRAMMING

Programming of the functions and times of the controller is performed using a special configuration menu that is accessed and explored using 3 keys, DOWN, MENU, and UP, which are located below the display.

⚠ CAUTION: Except in the configuration menu, pressing the UP key activates a START command and pressing the DOWN key activates a START PEDESTRIAN command.

To activate the programming modes (the display must show the control panel), press and hold down the MENU key until **-PrG** appears on the display.

Hold down the MENU key to scroll through the 4 main menus:

- PrG CONTROLLER PROGRAMMING
- Cnt COUNTERS
- APP SELF-LEARNING OF WORKING TIMES
- dEF LOAD DEFAULT PARAMETERS

To enter one of the four main menus, just release the MENU key when the menu you want appears on the display.

To move through the four main menus, press the UP and DOWN keys to scroll through the various items. Press the MENU key to display the current value of the selected item and change it if needed.

● KEY PRESSED

○ KEY RELEASED

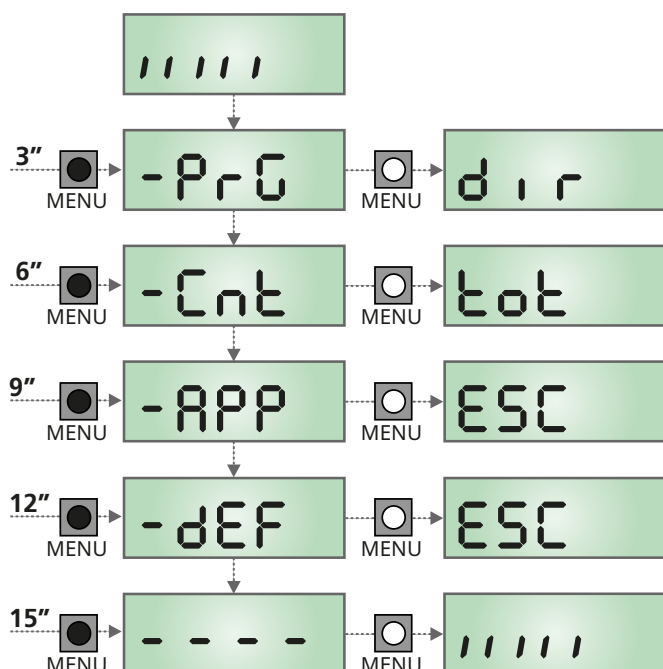

9 - QUICK CONFIGURATION

This paragraph concerns a quick procedure to set the control unit and set it at work immediately.

We recommend following these instructions, in order to check quickly the correct operation of control unit, motor and accessories, and then changing the configuration in case of any non-satisfactory parameter.

1. Call up the default configuration (chapter 10)

⚠ CAUTION: If there is only one motor, set the P0E2 parameter to n0 in order to inform the controller that the parameters for motor 2 do not need to be considered.

2. Set items S5oP - F0E1 - F0E2 - C0S1 - C0S2 according to the safety devices installed on the gate.
3. Start the self-learning cycle (chapter 11)
4. check that the automation work properly and if necessary modify the configuration of the desired parameters.

10 - LOADING OF DEFAULT PARAMETERS

If necessary, it is possible to restore all the parameters to their standard or default value (see table at the end)

⚠ WARNING: This procedure causes the loss of all the customized parameters, therefore it has been put outside the configuration menu, to reduce the possibility of executing it by mistake.

1. Press and hold down the MENU key until the -dEF appears on the display
2. Release the MENU key: the display will show ESC (press the MENU key only if you want to leave this menu)
3. Press the DOWN key: dEF will appear on the display.
4. Press the MENU key: no will appear on the display.
5. Press the DOWN key: S1 will appear on the display.
6. Press the MENU key: All of the parameters are returned to their default values (see the table on pages 37) and the display shows the control panel

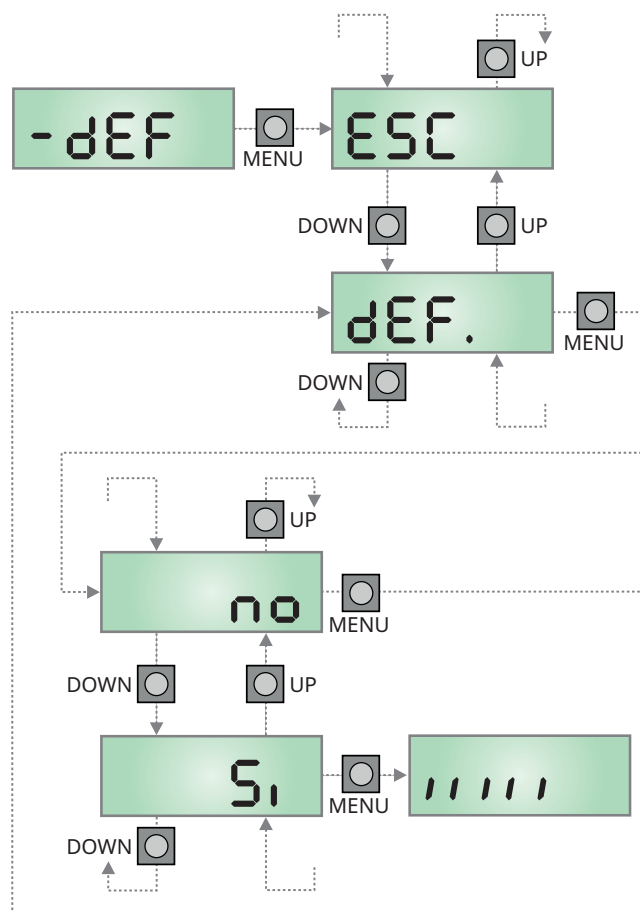

11 - SELF-LEARNING OF WORKING TIMES

This **MENU** allows the automatic learning of the times necessary to open and close the gate.

⚠ WARNING: to perform the automatic learning procedure it is necessary to:

- set the **SEn.E** parameter as default (**SEAn**)
- disable the **ADI** interface via the **ADi** MENU. If there are safety devices that are controlled via the **ADI** module during the self-learning phase, they will not be active.
- if you only perform the acquisition of the positions (point 4 of the sequence), first adjust the amperometric sensitivity (parameters **SEn.A** and **SEn.C**)

Place the doors, or door, at half run and proceed with the following points:

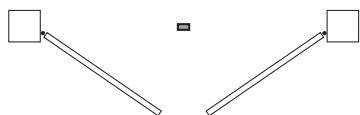

1. Press and hold the **MENU** key until the display shows **-APP**
2. Release the button **MENU** and select the type of learning you wish to perform using the buttons **UP** e **DOWN** :

ESC no learning is performed. Pressing the button **MENU** returns to normal operation

L.LAu **position learning**: the gate performs a cycle at reduced speed (**Po.AL** parameter) to acquire the limit switch positions. The procedure will take place as follows:

a. Door 1 is opened for a few seconds

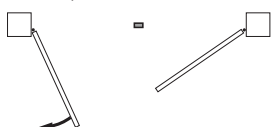

b. Door 2 is closed until the limit switches comes into action, or the sensor of obstacles detects that the door is locked

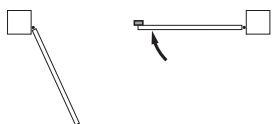

c. Door 1 is closed until the limit switches comes into action, or the sensor of obstacles detects that the door is locked

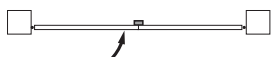

d. An opening manoeuvre for each door is carried out, the operation ends when the limit switches comes into action, or the sensor of obstacles detects that the door is locked

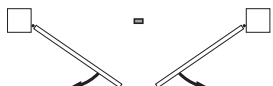

e. A closing manoeuvre for each door is carried out, the operation ends when the limit switches comes into action, or the sensor of obstacles detects that the door is locked

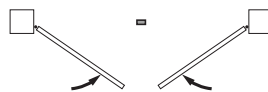

AMP **learning efforts**: the gate performs a cycle at normal speed to acquire the currents and stores the values of **SEn.A** and **SEn.C**

SMA **learning positions + efforts**: the gate first executes the learning positions cycle and then the learning efforts cycle

3. Press the button **MENU** to start the self-learning cycle: the display shows the control panel and the time self-learning procedure begins.

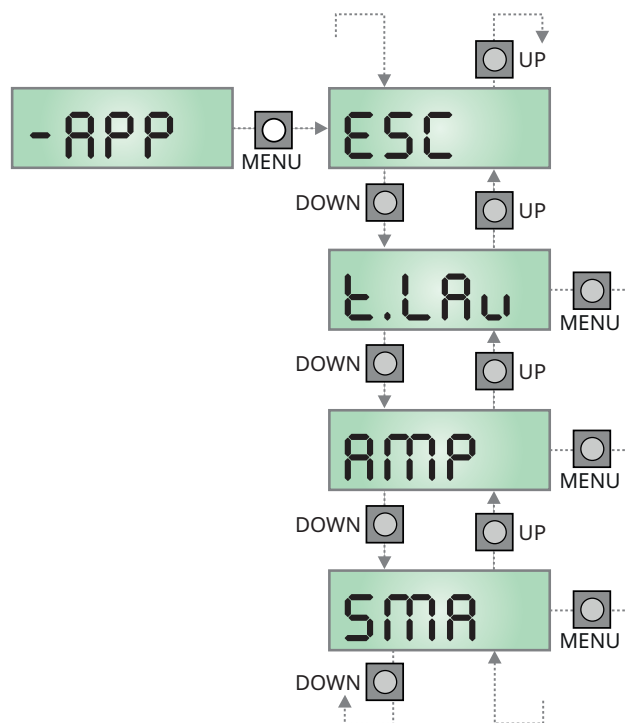

12 - EMERGENCY DEAD MAN OPERATION

This operational mode can be used to move the gate in DEAD MAN mode in case of malfunctioning of photocell, edge, limit switches or encoder.

To activate the function the START command must be pressed 3 times (presses must last at least 1 second; the pause between commands must last at least 1 second).

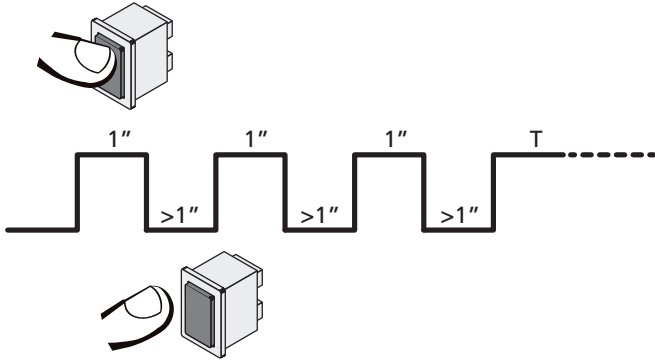

The fourth START command activates the gate in MAN PRESENT mode. To move the gate keep the START command pressed for the duration of the operation (time T). The function will automatically turn off after 10 seconds of inactivity of the gate.

NOTE: if the $S_{E_{R_{E}}}$ parameter is set as $S_{E_{R_{N}}}$, the Start command (from the terminal block or remote control) moves the gate in the open and closed directions alternatively (unlike the normal DEAD MAN mode).

13 - READING THE COUNTER OF THE CYCLES AND EVENTS MEMORY

CX EVO2 control unit counts the completed opening cycles of the gate and, if requested, it shows that service is required after a fixed number of cycles. Furthermore, events can be recorded which occurred during operation, associating to each a code and a date/time in which each occurred; this information must be communicated to the support service if problems arise.

ATTENTION: the correct date/time information of an event is stored only if the information is supplied to the control panel by a device equipped with a clock, such as the WiFi interface.

There are 3 counters available:

- A totalizing counter for completed opening cycles that cannot be zeroed (option $S_{E_{T_{E}}}$ of item $C_{N_{E}}$)
- A downward counter for the number of cycles before the next request for service (option $S_{E_{R_{U}}}$ of item $C_{N_{E}}$).
When the counter of missing cycles for the next maintenance intervention reaches zero, the control unit signals the maintenance request by means of an additional pre-flashing of 5 seconds. The signal is repeated at the beginning of each opening cycle, until the installer accesses the meter reading and setting menu, possibly programming the number of cycles after which maintenance will be required again. If a new value is not set (i.e. the counter is left at zero), the maintenance request signaling function is disabled and the signaling is no longer repeated.
- Events counter (option $E_{U_{E_{N}}}$)

The scheme hereafter shows how to read the totalizing counter, how to read the number of cycles before the next service is required as well as how to program the number of cycles before the next request for service (as for the example shown, the control unit completed no. 12451 cycles and there are no. 1300 cycles before the next service request; the code of the last recorded event is 176, and it occurred at 14.14.19 on 20 August.

Area 1 is the reading of the total number of completed cycles; through UP and DOWN keys, you can alternate the display of thousands or units.

Area 2 is the reading of the number of cycles before the next request for service: its value is rounded down to the hundreds.

Area 3 represents the setting of this counter: on first pressing of the key UP or DOWN the current value of the counter, it is rounded off to the thousand, every subsequent press increases the setting by 1000 units or decreases by 100. The previously displayed count is lost.

Area 4 represents reading of the events memory. The first data is an index that allows identification of the event: **n 1** is the last event recorded, **n 2** is the previous one and so on. The other data are automatically displayed in succession and provide information on the date/time (each data remains displayed for approximately one second, if you want to temporarily stop the display, keep the MENU key pressed); the last data displayed is the code of the event (in some cases, after the event code additional data is displayed), then the sequence restarts from the index.

The data are displayed for 1 minute, after which the display returns to normal view.

All events with their meaning can be viewed in the table available at the following link

EVENTS TABLE

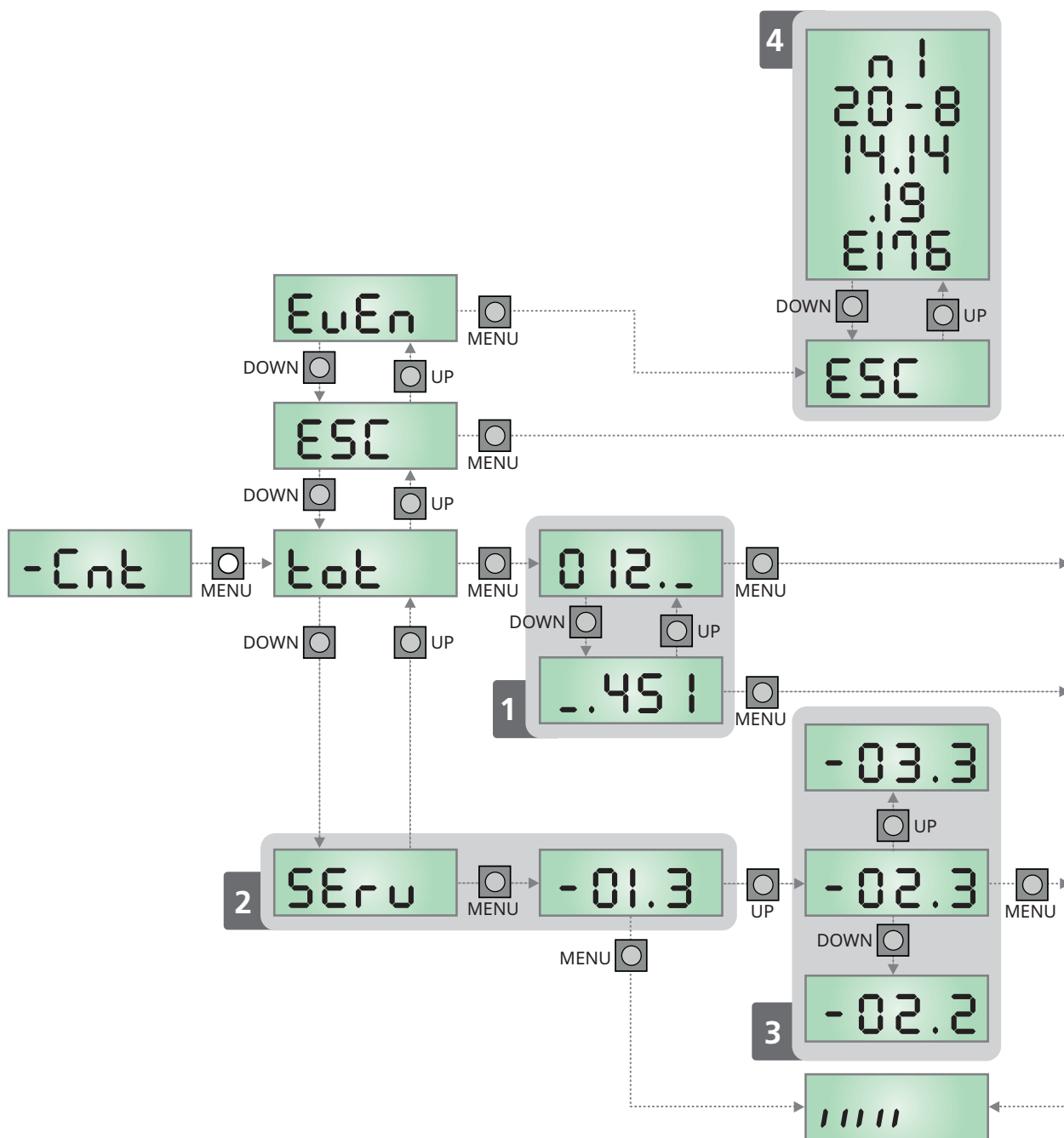

14 - CONTROL UNIT CONFIGURATION

Control unit time and function programming is made within a special configuration menu, to which you can access and where you can shift through DOWN, MENU and UP keys placed under the display.

Hold down the MENU key until **-PrG** appears on display, to activate the programming mode while display views the panel.

The configuration menu consists in a list of configurable items; the display shows the selected item.

- By pressing DOWN, you will pass to the next item
- By pressing UP, you will return to the previous item
- By pressing MENU, you can view the current value of selected item and possibly change it.

The last menu item (**FinE**) allows storing the carried out changes and going back to the control unit normal operation.



You must exit from programming mode through this menu item if you do not want to lose your configuration.

⚠ WARNING: in case no operation is carried out for more than one minute, the control unit exits from the programming mode without saving any of your setups and changes, which will get lost.

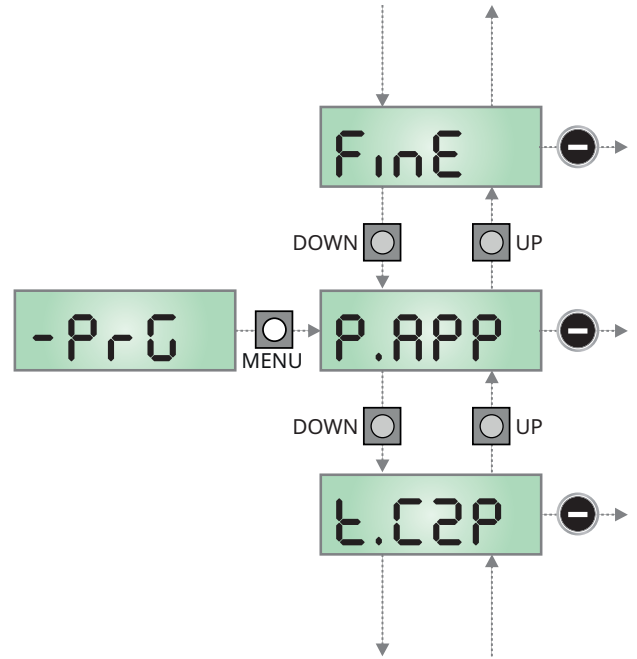

NOTE: By holding down the UP or DOWN keys, configuration menu items will scroll fast, until item **FinE** is viewed. In this way, you can quickly reach either the top or bottom of the list.



PARAMETER	VALUE	DESCRIPTION	DEFAULT
P.APP		Partial opening	25
	0 - 100	The percentage of the path the gate performs in the case of opening using the Pedestrian Start command	
E.C2P		Leaf 2 closing time during pedestrian cycle	no
	0.5" - 1'00	During a partial opening cycle (pedestrian access) leaf 2 may move slightly because of the wind or its own weight; in this case at closing time leaf 1 could hit leaf 2 and the gate would remain not perfectly closed. To avoid this, in the last seconds of the cycle a light closing force is applied to leaf 2 too.	
	no	Function deactivated	
r.AP		Opening door delay	1.0"
	0.0" - 1'00	During the opening phase, leaf 1 must start moving before leaf 2, to avoid that both doors may collide. Leaf 2 opening will be delayed for the setup time	
r.Ch		Closing door delay	3.0"
	0.0" - 1'00	During the closing phase, leaf 1 must start moving after leaf 2, to avoid that both doors may collide. Leaf 1 closing will be delayed for the setup time	
C2.rA		Leaf 2 closing during the opening delay	no
	no	Function disabled	
	Si	Function enabled	

PARAMETER	VALUE	DESCRIPTION	DEFAULT
Ł.SEr		Lock time	2.0"
	0.5" - 1'00	Before the opening phase begins, the control unit will energize the electric lock in order to release it and enable the gate motion. Ł.SEr time will fix the energizing time.	
		 WARNING: in case the gate has no electric lock, set the value no	
	no	Function deactivated	
Ł.RSE		Lock advance time	1.0"
	0.0" - 1'00	While the electric lock is energized, the gate will stay standstill for Ł.RSE time, to make its release easier. In case Ł.RSE is lower than Ł.SEr , the lock energizing will go on while the doors will start moving.	
		 WARNING: in case the gate has no electric lock, set the value 0.0"	
SEr.S		Silent Locking Mode	Si
	Si	Function activated	
	no	Function deactivated	
Ł.inu		Backlash time	no
	0.5" - 1'00	It could be useful to give a closing command to motors, to help the electric lock release. The control unit controls the motors in reduced power in closing direction for the setup time	
	no	Function deactivated	
Ł.PrE		Pre-blinking time	1.0"
	0.5" - 1'00	Before any gate movement, blinker will be activated for Ł.PrE time, to warn about the incoming motion	
	no	Function deactivated	
Ł.PCh		Different closing pre-flashing time	no
	0.5" - 1'00	If this parameter has a value assigned to it, the control unit will activate pre-flashing prior to closure for the length of time set in this menu (adjustable time from 0.5" to 1'00)	
	no	The closing pre-flashing time corresponds to Ł.PrE	
PoŁ1		Motor 1 power	80
	30-100	The displayed value is the percentage of max. motor power	
PoŁ2		Motor 2 power	80
	30-100	The displayed value is the percentage of max. motor power	
	no	Single leaf operation	
Po.r1		Power motor 1 during slow-down phase	30
	10-70	The displayed value is the percentage of max. motor power	
Po.r2		Power motor 2 during slow-down phase	30
	10-70	The displayed value is the percentage of max. motor power	
Po.AL		Power used for realignment on the limit switch	50
	10 - 70	Power used in searching for the position of the limit switch, in the self-learning phases or after the reset	

PARAMETER	VALUE	DESCRIPTION	DEFAULT
SPUn		Start off When the gate is standstill and it begins moving, the initial inertia must be faced, therefore, if your gate is quite heavy, its doors could not move. In case the SPUn (pickup) function is activated, for the first 2 seconds of motion of each door, the control unit will ignore both Pot1 and Pot2 values and it will give motors the maximum power command in order to overcome the gate inertia.	no
	Si	Function activated	
	no	Function deactivated	
rAM		Starting ramp	4
	0-10	In order not to stress too much the motor, when the motion starts the power is gradually increased, until reached the set value or 100% if the take-off is enabled. Higher is the set value, longer the length of time of the ramp, that is the time necessary to reach the value of nominal power.	
SEn1		Enable the obstacle sensor for motor 1	no
	1.0A-12.0A	This menu allows you to regulate the sensitivity of the obstacle sensor for motor 1. When the current absorbed by the motor exceeds the set value, the controller detects an alarm. When the sensor intervenes, the gate stops and is operated in the reverse direction for 3 seconds to remove the obstacle. The next start command restarts the movement in the previous direction. NOTE: If set to 0.0A, this function is disabled ⚠ WARNING: if either the limit switches or the slowing down are disabled, when detected an obstacle the control unit stops the opening or closing phase without inverting the motion.	
	no	Function deactivated	
SEn2		Enable the obstacle sensor for motor 2	no
	1.0A-12.0A	This menu allows you to regulate the sensitivity of the obstacle sensor for motor 2. When the current absorbed by the motor exceeds the set value, the controller detects an alarm. When the sensor intervenes, the gate stops and is operated in the reverse direction for 3 seconds to remove the obstacle. The next start command restarts the movement in the previous direction. NOTE: If set to 0.0A, this function is disabled ⚠ WARNING: if either the limit switches or the slowing down are disabled, when detected an obstacle the control unit stops the opening or closing phase without inverting the motion.	
	no	Function deactivated	
SEn.u		Speed sensor adjustment	1
	0 - 7	This menu allows you to adjust the sensitivity of the speed sensor (virtual encoder), which determines any stalling. 0 = minimum sensitivity 7 = maximum sensitivity When the sensor intervenes the control unit behaves as if it detected an obstacle.	
rARP		Slow down in opening	20
	0 - 100	This menu allows regulating the percentage of the ride/drive that is carried out at reduced speed during the last opening stretch	
rRCh		Slow down in closing	20
	0 - 100	This menu allows regulating the percentage of the ride/drive that is carried out at reduced speed during the last closing stretch	

PARAMETER	VALUE	DESCRIPTION	DEFAULT
MFC		Edge of the limit switch This menu allows you to establish that an obstacle, even if detected before pause positioning (gate open) is however interpreted as a mechanical stop.	10
	0 - 40	Percentage of the stroke relating to the edge	
	no	Function disabled	
E.CuE		Fast closing time after slowing down	0.0"
	0.0" - 5.0"	If a slowing time other than 0 is set up, it could be likely that the gate speed is not enough for the lock to fasten during the closing phase. In case this function is enabled, once the slowing down phase is finished, the control unit will give a normal speed command (that is to say, with no slowing down) for the set up time.  WARNING: in case the gate has no electric lock, set the value 0.	
St.AP		Start command during the opening phase This menu allows fixing the control unit conduct in case it receives a Start command during the opening phase	PAUS
	PAUS	The gate stops and goes to pause	
	ChiU	The gate immediately starts closing	
	no	The gate go on with the opening phase (command is ignored)	
St.Ch		Start command during the closing phase This menu allows fixing the control unit conduct in case it receives a Start command during the closing phase	StoP
	StoP	The gate stops and its cycle is considered as finished	
	APEr	The gate opens again	
St.PA		Start command during the pause This menu allows fixing the control unit conduct in case it receives a Start command when the gate is open during its pause phase	ChiU
	ChiU	The gate starts closing	
	no	Command is ignored	
	PAUS	The pause time is reset (Ch.AU)	
SPAP		Pedestrian Start during the partial opening phase This menu allows fixing the control unit conduct in case it receives a Pedestrian Start command during the partial opening phase.  WARNING: a Start command in any phase of partial opening will cause the total opening; the Start Pedestrian command is always ignored during a total opening.	PAUS
	PAUS	The gate stops and goes to pause	
	ChiU	The gate immediately starts closing	
	no	The gate goes on with the opening phase (command is ignored)	
Ch.AU		Automatic closing	no
	no	Function deactivated	
	0.5" - 20.0'	The gate closes after the setup time	

PARAMETER	VALUE	DESCRIPTION	DEFAULT
Ch.Tr		Closing after transit This function allows having a fast closing as soon as transit through the gate is completed, therefore, a time shorter than Ch.RU is generally used	no
	no	Function deactivated. The gate closes after the time set for the function Ch.RU	
	0.5" - 20.0'	The gate closes after the setup time	
PA.Tr		Pause after transit Per rendere minimo il tempo in cui il cancello rimane aperto, è possibile fare in modo che il cancello si fermi non appena viene rilevato il passaggio davanti alle fotocellule. Se abilitato il funzionamento automatico, come tempo di pausa viene caricato il valore Ch.Tr	no
	no	Function deactivated	
	Si	Function activated	
LUC.		Courtesy lights This menu allows setting the automatic operating of the courtesy lights during the opening cycle of the gate.	t.LUC 1'00
	t.LUC	Timed operation (from 0 to 20 min)	
	no	Function disabled	
	CiCL	On for the entire cycle duration	
AUS		Auxiliary channel This menu allows setting the operating of the relay of the lighting of the courtesy lights by means of a remote control stored on the channel 4 of the receiver.	Mon
	t im	Timed operation (from 0 to 20 s)	
	bist	Bistable operation	
	Mon	Monostable operation	
SP.A		Low voltage output setup This menu allows you to set the operation of the low voltage output.	FLSh
	no	Not used	
	FLSh	Flasher operation (fixed frequency)	
	W.L.	Indicator light operation: Indicates the status of the gate in real-time. The type of blinking indicates the four possible conditions: - GATE STOPPED: Light off - GATE IN PAUSE: the light is on, fixed - GATE OPENING: the light blinks slowly (2 Hz) - GATE CLOSING: the light blinks quickly (4 Hz)	
LP.PA		Blinker during pause time	no
	no	Function deactivated	
	Si	Blinker will be on during the pause time too	

PARAMETER	VALUE	DESCRIPTION	DEFAULT
StEt		Activation inputs function This menu allows selecting input operation modes (see chapter 4.4)	StAn
	StAn	Standard mode	
	no	Start inputs from terminal board are disabled. Radio inputs operate in standard mode StAn	
	St.Fi	Start + fire sensor	
	St.Pr	Start + presence detector or magnetic loop	
	AP.Ch	Open/Close command	
	d.MA	Manned operation	
	oroL	Timer mode	
StoP		Stop Input	no
	no	The input STOP is not available (ignored by the control unit)	
	ProS	The input STOP stops the gate: pressing the command START the gate continues the motion	
	inuE	The command STOP stops the gate: at the next START the gate starts moving in the opposite direction	
FoEt1		Photocell 1 input This menu allows enabling the input for type 1 photocells, that is to say, photocells active both during the opening and closing phase	no
	no	Input disabled. No jumper with the common is required	
	AP.Ch	Input enabled	
FoEt2		Photocell 2 input This menu allows enabling the input for type 2 photocells, that is to say, photocells non active during the opening phase	CFCh
	CFCh	Input enabled even at standstill gate too	
	no	Input disabled. No jumper with the common is required	
	Ch	Input enabled for the closing phase only WARNING: if you select this option, you must disable photocell test	
FtEtE		Test of the photocells In order to achieve a safer operation for the user, the unit performs a photocells operational test, before a normal working cycle. If no operational faults are found, the gate starts moving. Otherwise, it will stand still and the flashing light will stay on for 5 sec. The whole test cycle lasts less than one second	no
	no	Function deactivated	
	Si	Function activated	
CoSi		Safety ribbon 1 input This menu allows enabling the input for type 1 safety ribbon, that is to say, fixed ribbons	no
	no	Input disabled (ignored by the control unit)	
	AP	Input enabled during the opening and disabled during the closure	
	APCh	Input enabled in opening and closure	
	StoP	Activating the input during both opening and closing causes the gate to stop immediately.	

PARAMETER	VALUE	DESCRIPTION	DEFAULT
CoS2		Safety ribbon 2 input This menu allows enabling the input for type 2 safety ribbon, that is to say mobile ribbons	no
	no	Input disabled (ignored by the control unit)	
	RPCh	Input enabled in opening and closure	
	Ch	Input enabled during closure and disabled during opening	
	StoP	Activating the input during both opening and closing causes the gate to stop immediately.	
Co.tE		Test of the safety edges This menu allows setting the method of control of the safety edges working	no
	no	Test disabled	
	rESi	Test enabled for conductive rubber safety edges	
	Foto	Test enabled for optical safety edges	
FC.En		End of Stroke Inputs	no
	no	End of stroke inputs are disabled	
	L.SW'	End of stroke equipped with a normally close switch	
	Cor.O	End of stroke in series of motor winding	
EnCo		Encoder input	no
	no	Input disabled	
	1 Ch	Management of 1 channel encoder	
	2 Ch	Management of 2-channel quadrature encoders	
rLR		Motor Release on Mechanical Stop When the gate halts against the mechanical stop, the motor is controlled for a fraction of a second in the opposite direction, decreasing the motor gear tension	2
	0	Function disabled	
	1 - 10	Time motor release (max. 1 second)	
i.Ad1		Enabling the ADI device This menu makes it possible to enable operation of the device connected to the ADI connector. PLEASE NOTE: selecting S1 and pressing MENU accesses the configuration menu for the device connected to the ADI connector. This menu is managed by the device itself and is different for each device. Please refer to the manual for the device. If the S1 option is selected, but no device is connected, the display will show a series of dotted lines. Exiting the ADI device configuration menu returns to the i.Ad1 option	no
	no	Interface disabled, any signals will be ignored	
	S1	Interface enabled	

PARAMETER	VALUE	DESCRIPTION	DEFAULT
RSM		<p>Anti-skid</p> <p>When an opening or closing operation is interrupted by a command or for the intervention of the photocell, the set-up time for the opposite movement would be excessive, so the control unit operates the motors only for the time necessary to recover the actually covered journey.</p> <p>This could be not sufficient, particularly in the case of very heavy gates, as because of the inertia at the inversion moment the gate runs an extra space in the previous direction that the control unit is not able to take into account. If after an inversion the gate does not return exactly to the starting position, it is possible to set an anti-skid time that is added to the time calculated by the control unit in order to recover the inertia.</p>	2.0"
	no	Function disabled	
	0.0" - 1.0"	Anti-skid time	
FinE		<p>End of Programming</p> <p>This menu allows to finish the programming (both default and personalized) saving the modified data into memory</p>	no
	no	It does not exit from the program menu	
	Si	It exits from the program menu by storing the setup parameters	

13 - OPERATION DEFECTS

This paragraph shows some possible operation defects, along with their cause and applicable remedy.

Some anomalies are signalled using a message on the display, others with flashing signs or the leds assembled on the control unit.

DISPLAYING	DESCRIPTION	SOLUTION
OVERLOAD led is on	It means that there is an overload on accessory power supply	<ol style="list-style-type: none"> 1. Remove the extractable part containing terminals J1 - J9 . OVERLOAD led will switch off. 2. Remove the overload cause. 3. Reinsert the terminal board extractable part and check that this led is not on again.
Too long pre-blinking	When a Start command is given and the blinker switches on immediately but the gate is late in opening	It means that the setup cycle count down expired and the control unit shows that service is required
The display shows Err2	When a start command is given the gate won't open. It means that MOSFET test failed.	Before sending the control unit to V2 S.p.A. for repair, be sure that motors have been properly connected.
The display shows Err3	When a start command is given the gate won't open. It means that the photocell test failed.	<ol style="list-style-type: none"> 1. Be sure that no obstacle interrupted the photocell beam when the Start command was given. 2. Be sure that photocells, as enabled by their relevant menus, have been installed actually. 3. If you have photocells 2, be sure that Fot2 menu item is on CF.Ch. 4. Be sure that photocells are powered and working: interrupt the ray and check that the photocell segment on the display changes position.
The display shows Err4	When a Start command is given and the gate does not open	<p>This anomaly can occur when in one of the following conditions:</p> <ol style="list-style-type: none"> 1. If a START command is sent with the motor released. 2. During the self-learning cycle if there are any problems with the range limits. If the magnets are installed correctly, it means that the limit switch sensor is damaged or the cabling connecting the sensor to the central control unit is broken/damaged. Change the end of stroke sensor or the broken wiring. 3. During normal operation. If the error persists send the control unit to V2 S.p.A. for repair.
The display shows Err5	When a start command is given the gate won't open. It means that the test of the safety edges failed.	<ol style="list-style-type: none"> 1. Make sure that the menu relative to the test of the facets for cables (Co.tE) is configured correctly. 2. Make sure that the safety edges enabled by menu are actually installed.
The display shows Err6	The MOSFET verification circuit is faulty	Contact the V2 technical assistance service to send the control unit for repair