

# INDEX

<b>1 - GENERAL WARNINGS: SAFETY - INSTALLATION</b> .....	32
1.1 - INSTALLATION WARNINGS .....	33
1.2 - PRELIMINARY CHECKS AND IDENTIFICATION OF THE TYPE TO BE USED .....	33
1.3 - EU DECLARATION OF CONFORMITY .....	34
<b>2 - TECHNICAL DATA</b> .....	35
<b>3 - INSTALLATION OF THE MOTOR</b> .....	36
3.1 - INSTALLATION OF THE MOTOR .....	36
3.2 - MOUNTING THE RACK .....	37
3.3 - FIXING OF THE MOTOR .....	37
3.4 - INSTALLING THE MAGNETIC LIMIT SWITCHES .....	38
3.5 - MOTOR OVERRIDING SYSTEM .....	39
3.6 - INSTALLATION LAYOUT .....	39
<b>4 - CONTROL UNIT</b> .....	40
4.1 - POWER SUPPLY .....	40
4.2 - FLASHING LIGHT .....	40
4.3 - COURTESY LIGHTS .....	40
4.4 - ACTIVATION INPUTS .....	40
4.5 - STOP .....	40
4.6 - PHOTOCELLS .....	41
4.7 - SAFETY RIBBONS .....	42
4.8 - EXTERNAL AERIAL .....	42
4.9 - ELECTRICAL CONNECTION .....	42
4.10 - PLUG IN RECEIVER .....	44
4.11 - ADI INTERFACE .....	44
<b>5 - CONTROL PANEL</b> .....	45
5.1 - DISPLAY .....	45
5.2 - USE OF THE KEYS FOR PROGRAMMING .....	45
<b>6 - ACCESSING THE CONTROL UNIT SETTINGS</b> .....	46
<b>7 - QUICK CONFIGURATION</b> .....	46
<b>8 - LOADING THE DEFAULT PARAMETERS</b> .....	46
<b>9 - SELF-LEARNING OF WORKING TIMES</b> .....	47
<b>10 - EMERGENCY DEAD MAN OPERATION</b> .....	47
<b>11 - READING THE COUNTER OF THE CYCLES AND EVENTS MEMORY</b> .....	48
<b>12 - PROGRAMMING THE CONTROL UNIT</b> .....	50
<b>13 - OPERATION DEFECTS</b> .....	56
<b>14 - TESTING AND START-UP</b> .....	58
<b>15 - MAINTENANCE</b> .....	58
<b>16 - DISPOSAL OF THE PRODUCT</b> .....	58

## 1 - GENERAL WARNINGS: SAFETY - INSTALLATION

 **These warnings are copies straight from the Regulations and as far as possible applicable to the product in question.**

 **ATTENTION: Important safety instructions. Follow all instructions as improper installation may cause serious damage.**

 **ATTENTION: Important safety instructions. It is important for you to comply with these instructions for your own and other people's safety. Keep these instructions**

- Before commencing the installation, check the "Technical characteristics" (in this manual), in particular whether this product is suitable for automating your guided part. If it is not suitable, DO NOT continue with the installation
- The product cannot be used before it has been commissioned as specified in the chapter on "Testing and commissioning"

 **ATTENTION: According to the most recent European legislation, the implementation of an automation system must comply with the harmonised standards provided by the Machinery Directive in force, which enables declaration of the presumed conformity of the automation. Taking this into account, all operations regarding connection to the electricity grid, as well as product testing, commissioning and maintenance, must be performed exclusively by a qualified and skilled technician!**

- Before proceeding with the installation of the product, check that all the materials are in good working order and suited to the intended applications
- This product is not intended to be used by persons (including children) whose physical, sensory or mental capacities are reduced, or who lack the necessary experience or skill
- Children must not play with the appliance
- Do not allow children to play with the fixed control devices of the product. Keep the remote controls away from children.

 **ATTENTION In order to avoid any danger from inadvertent resetting of the thermal cut-off device, this appliance must not be powered through an external switching device, such as a timer, or connected to a supply that is regularly powered or switched off by the circuit**

- Provide a disconnection device (not supplied) in the plant's power supply grid, with a contact opening distance permitting complete disconnection under the conditions dictated by overvoltage category III
- Handle the product with care during installation, taking care to avoid crushing, denting or dropping it, or allowing contact with liquids of any kind. Keep the product away from sources of heat and naked flames. Failure to observe the above can damage the product, and increase the risk of danger or malfunction. Should this happen, stop installation immediately and contact Customer Service
- The manufacturer assumes no liability for damage to property, items or persons resulting from non-compliance with the assembly instructions. In such cases the warranty for material defects is excluded

- The weighted sound pressure level of the emission A is lower than 70 dB(A)
- Cleaning and maintenance reserved for the user must not be carried out by children
- Before working on the system (maintenance, cleaning), always disconnect the product from the mains power supply
- Check the system periodically, in particular all cables, springs and supports to detect possible imbalances, signs of wear or damage. Do not use if repairs or adjustments are necessary, since installation failure or an incorrectly balanced door may cause injury
- The packing materials of the product must be disposed of in compliance with local regulations
- When operating a biased-off switch, make sure that other persons are kept away
- When operating the gate, keep an eye on the automated mechanism and keep all bystanders at a safe distance until the movement has been completed
- Do not operate the product if anyone is working nearby; disconnect its power supply before permitting such work to be done

### 1.1 - INSTALLATION WARNINGS

- Prior to installing the drive motor, check that all mechanical components are in good working order and properly balanced, and that the automation moves correctly
- If the gate or door being automated has a pedestrian gate, then the system must include a control device that will inhibit the operation of the motor when the pedestrian gate is open
- Make sure that the control devices are kept far from moving parts but nonetheless in a visible position. Unless a selector is used, the control devices must be installed at a height of at least 1.5 m and must not be accessible
- That windows, having a gap exceeding 200 mm when open, are to be closed using a biased-off switch if the opening movement is controlled by a fire-sensing system
- Ensure that entrapment between the driven part and the surrounding fixed parts due to the opening movement of the driven part is avoided
- Permanently fix the label concerning the manual release adjacent to its actuating member
- After installing the drive motor, make sure that the mechanism, protective system and all manual manoeuvres operate properly

## 1.2 - PRELIMINARY CHECKS AND IDENTIFICATION OF THE TYPE TO BE USED

The automation device should not be used until installation, as specified in “Testing and start-up”, has been performed. It should be remembered that the device does not compensate for defects caused by improper installation, or poor maintenance, thus, prior to proceeding with installation, ensure that the structure is suitable and meets current standards and, if necessary, perform any structural modifications aimed at the implementation of safety gaps and the protection or segregation of all crushing, shearing and transit zones, and verify that:

- The gate has no friction points, either during closing or opening.
- The gate must be equipped with mechanical stoppers.
- The gate is well balanced, i.e. there is no tendency to move spontaneously when stopped in any position.
- The position identified for fixing the motor reducer allows easy and safe manual manoeuvring, compatible with the size of the motor reducer itself.
- The support on which the automation device will be fixed is solid and durable.
- The mains power supply to which the automation device is connected has a dedicated safety earthing system and differential breaker with tripping current less than or equal to 30 mA (the breaker gap distance should be greater than or equal to 3 mm).

**Warning: The minimum safety level depends on the type of use; please refer to the following outline:**

TYPE OF ACTIVATION COMMANDS	CLOSURE USE TYPE		
	GROUP 1 Informed people (use in private area)	GROUP 2 Informed people (use in public area)	GROUP 3 Informed people (unlimited use)
Man-present command	A	B	Not possible
Remote control and closure in view (e.g. infrared)	C or E	C or E	C and D or E
Remote control and closure not in view (e.g. radio)	C or E	C and D or E	C and D or E
Automatic control (e.g. timed closure control)	C and D or E	C and D or E	C and D or E

**GROUP 1** - Only a limited number of people are authorised for use, and closure is not in a public area. Examples of this type are gates inside business premises, where the sole users are employees, or a part of them who have been suitably informed.

**GROUP 2** - Only a limited number of people are authorised for use, but in this case, closure is in a public area. An example of this may be a company gate that accesses onto a public street, and which is only used by employees.

**GROUP 3** - Anyone can use the automated closure, which is thus located on public land. For example the access gate to a supermarket or an office, or a hospital.

**PROTECTION A** - Closure is activated by means of a control button with the person present, i.e. with maintained action.

**PROTECTION B** - With the person present, closure is activated by a command controlled by means of a key-switch or the like, in order to prevent use by unauthorised persons.

**PROTECTION C** - Restricts the force of the leaf of the door or gate. I.e., in the case of the gate striking an obstacle, the impact force must fall within a curve established by the regulations.

**PROTECTION D** - Devices, such as photocells, capable of detecting the presence of people or obstacles. They may be active on just one side or on both sides of the door or gate.

**PROTECTION E** - Sensitive devices, such as footboards or immaterial barriers, capable of detecting the presence of a person, and installed in such a way that the latter cannot be struck in any way by a moving leaf or panel. These devices should be active within the entire “danger zone” of the gate. The Machinery Directive defines “Danger Zone” as any zone surrounding and/or near machinery where the presence of an exposed person constitutes a risk to the health and safety of that person.

**The risk analysis should take into consideration all danger zones for the automation device, which should be appropriately protected and marked.**

**In a clearly visible area, apply a sign with information identifying the motorised door or gate.**

**The installer should provide the user with all the information relating to automatic operation, emergency opening and maintenance of the motorised door or gate.**

### 1.3 - EU DECLARATION OF CONFORMITY AND DECLARATION OF INCORPORATION OF PARTLY COMPLETED MACHINE

Declaration in accordance with Directives: 2014/35/UE (LVD); 2014/30/UE (EMC); 2006/42/CE (MD) ANNEX II, PART B

The manufacturer V2 S.p.A., headquarters in Corso Principi di Piemonte 65, 12035, Racconigi (CN), Italy

Under its sole responsibility hereby declares that: the partly completed machinery model(s):

**SL MEDIUM 1000 24**

Description: electromechanical actuator for sliding gates

- is intended to be installed on sliding gates, to create a machine according to the provisions of the Directive 2006/42/EC. The machinery must not be put into service until the final machinery into which it has to be incorporated has been declared in conformity with the provisions of the Directive 2006/42/EC (annex II-A).
- is compliant with the applicable essential safety requirements of the following Directives: Machinery Directive 2006/42/EC (annex I, chapter 1) Low Voltage Directive 2014/35/EU Electromagnetic Compatibility Directive 2014/30/EU Directive RoHS3 2015/863/EU

Furthermore, the product complies with the following standards:

EN IEC 61000-6-2:2019, EN IEC 61000-6-3:2021  
EN 60335-1:2012 + A11:2014 + A13:2017 + A1:2019 + A2:2019 + A14:2019 + A15:2021, EN 62233:2008, EN 60335-2-103:2015

The relevant technical documentation is available at the national authorities' request after justifiable request to:

V2 S.p.A.  
Corso Principi di Piemonte 65, 12035, Racconigi (CN), Italy

The person empowered to draw up the declaration and to provide the technical documentation:

**Roberto Rossi**

Legal representative of V2 S.p.A.  
Racconigi, 10/01/2024

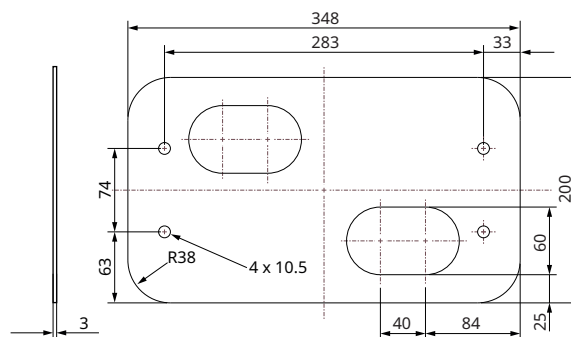
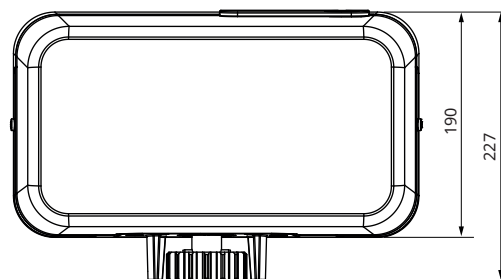
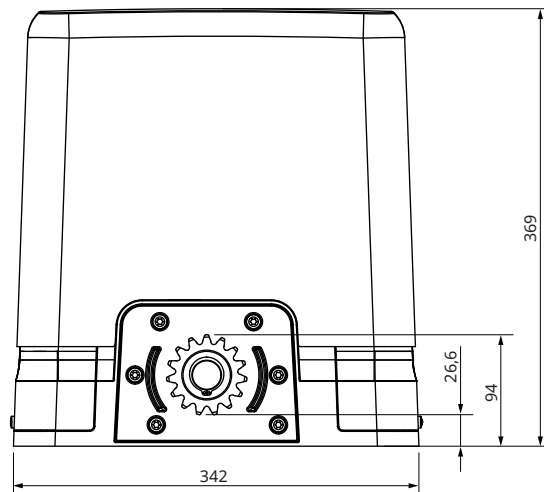
### PRODUCT COMPLIANCE WITH EU REGULATION 2023/826 (Standby)

This product complies with the criteria set out in the "Standby" regulation. The control panel goes into Standby Mode after one of its main functions ends.

This product has a STBY PWR output from which you can draw power for additional accessories.

This product has a RECEIVER connector and an ADI connector onto which accessory cards can be inserted for additional functions.

When calculating consumption in Standby Mode, the energy consumption of the accessories was not considered. Check the consumption of these accessories in the respective instructions.

## 2 - TECHNICAL DATA

	<b>SL MEDIUM 1000 24</b>
Gate maximum weight	1200 Kg
Power supply	230~ 50/60Hz
Maximum / rated power	600 / 250 W
Maximum/nominal leaf speed	41 / 22 cm/s
Maximum / nominal thrust	1000 / 300 N
Cycles / hour (4 meter gate)	35
Pinion	M4-Z15
Operating temperature	-20 +55 °C
Engine weight	15,5 Kg
Protection	IP44
Max load of accessories powered at 24 Vdc (terminals Z1-Z2, Z3-Z2)	12W
Protection fuses	F5A - 250V

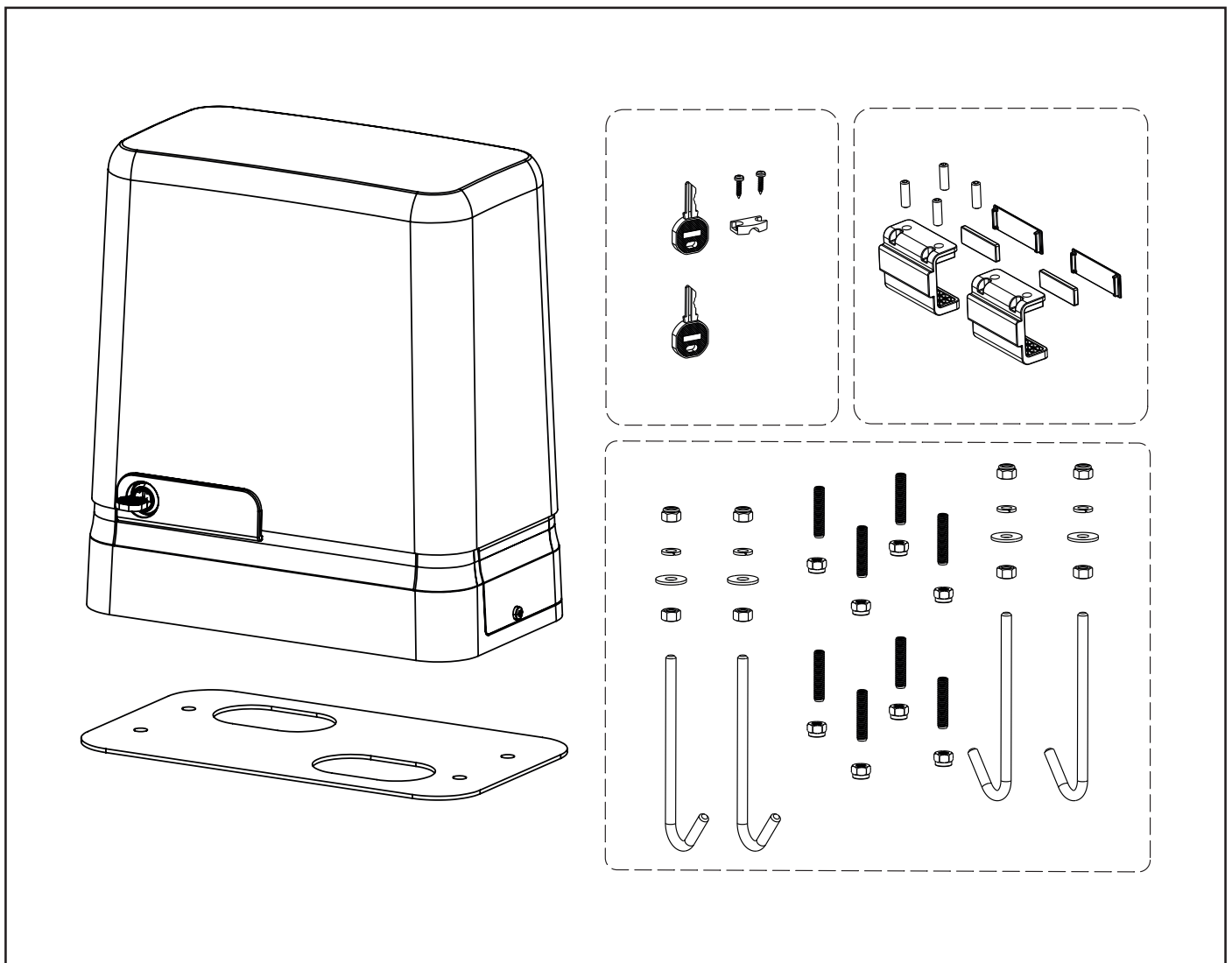

### 3 - INSTALLATION OF THE MOTOR

#### 3.1 - POSITIONING OF THE MOTOR

To fix the motor, follow the instructions below:

1. Use the measurements indicated in the drawing for the foundations
2. Arrange for one or two pipes for the passage of electric cables
3. Assemble the 4 clamps on the anchoring plate and fix them with the 8 bolts issued with the motor
4. Pour the concrete and position the anchoring plate

**⚠ WARNING: check that the plate be on a perfectly levelled surface and parallel to the gate**

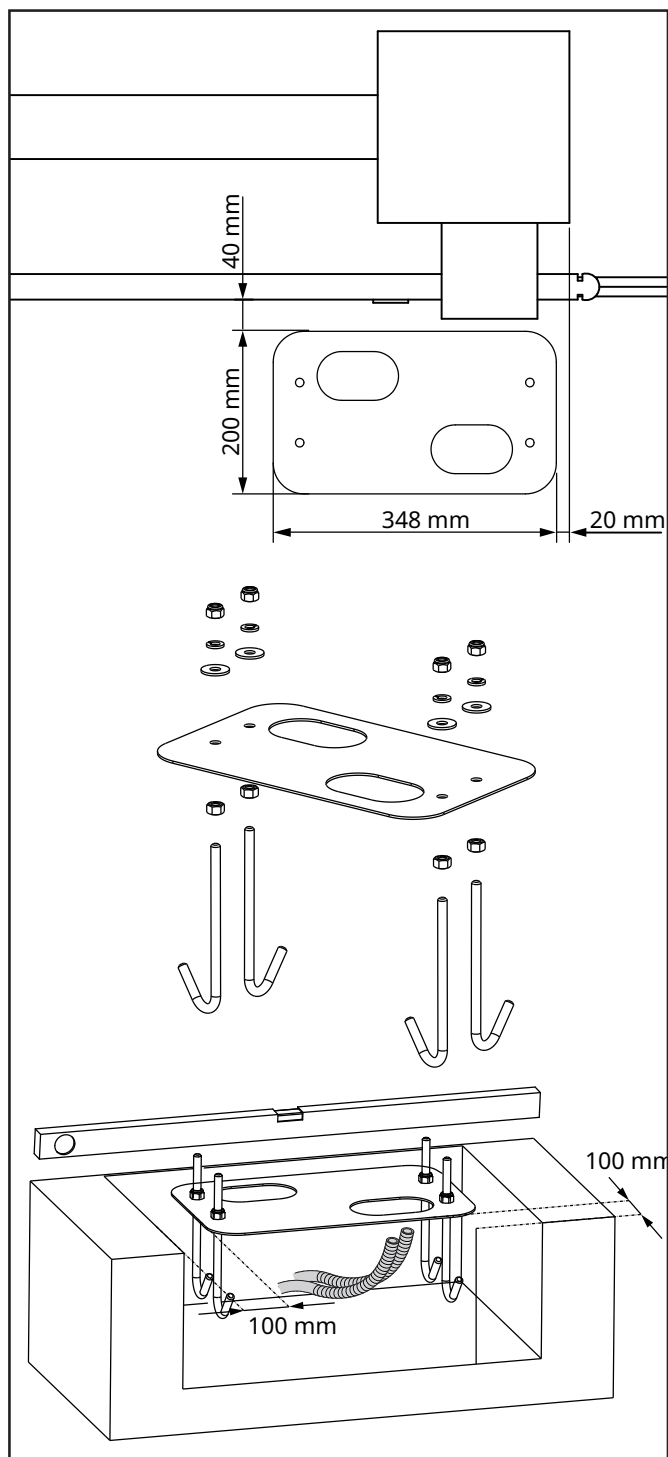

5. Wait for the complete setting of the concrete
6. Unscrew the 4 bolts fixing the base to the clamps and put the motor on the plate
7. Insert the 4 grains with their nuts in the proper place. Adjust the 4 grains to make the motor be perfectly levelled
8. Control that the motor is perfectly parallel to the gate, then insert 4 flat washers **R**, 4 grower washers **Q** and lightly screw the 4 bolts **D**

**⚠ WARNING: put the washer G into the hole for the passing of the cables as shown in the picture. Pierce the washer to let the cable to be connected to the control unit pass, paying attention to the dimensions in order to avoid the entrance of insects and other small animals.**

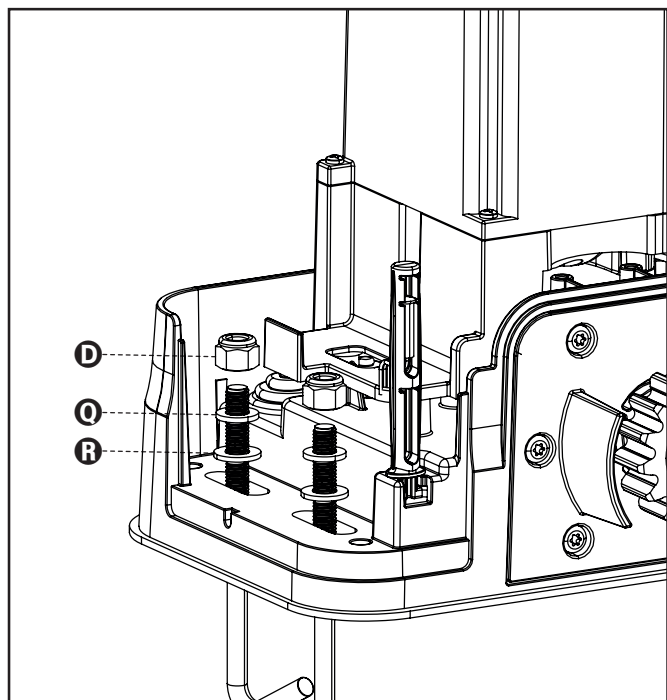
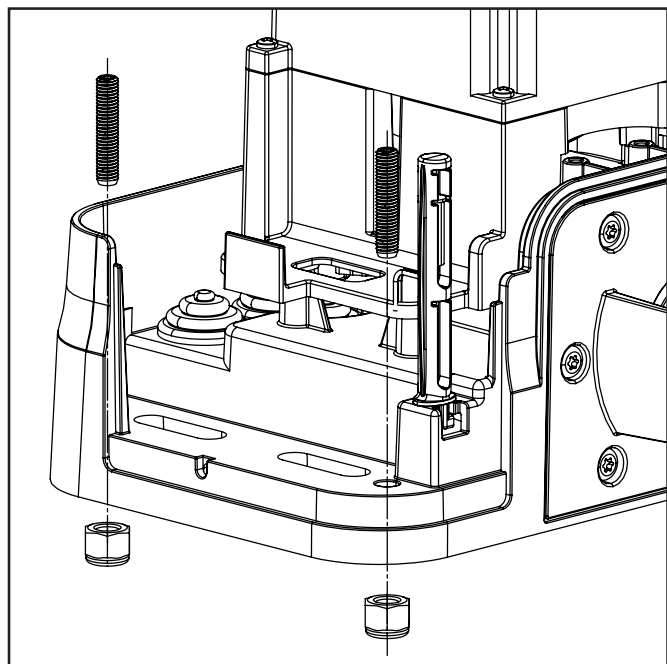

### 3.2 - MOUNTING THE RACK

1. Release the motor and turn the gate completely open.
2. Fix all the rack elements to the gate, making sure that they stand at the same height than the motor pinion.

The rack **MUST BE** positioned 1 or 2 mm over the pinion of the motor all the gate length.

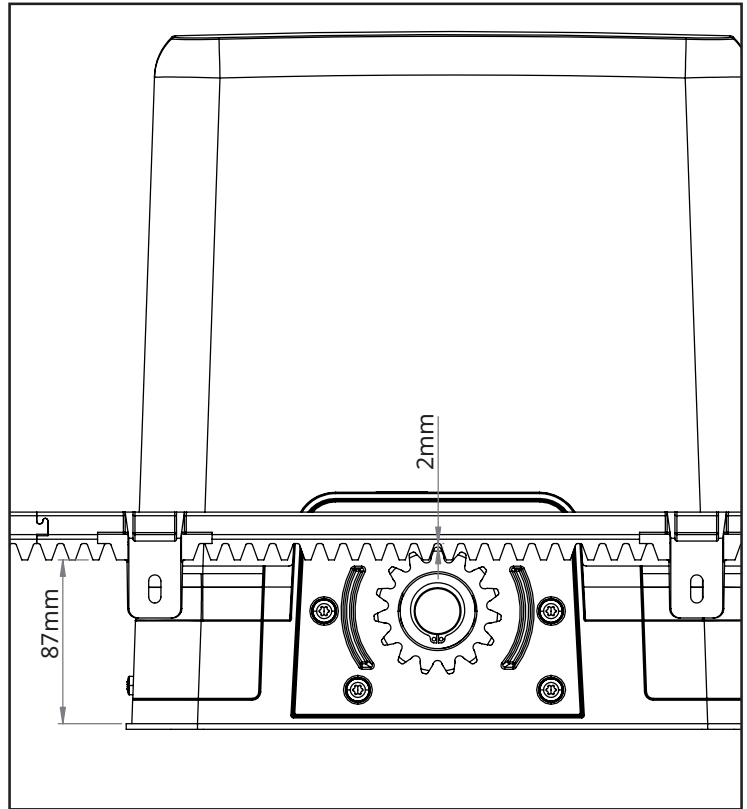

### 3.3 - FIXING OF THE MOTOR

Check the following points:

1. the motor must be on a levelled surface and perfectly parallel to the gate
2. the distance between pinion and rack must be 1 or 2 mm. If needed, adjust the 4 grains
3. the rack must be trued up with the pinion of the motor
4. the minimum distance between the maximum overall of the gate and the case of the pinion of the motor must be of at least 5 mm
5. Check the above indicated conditions and proceed fixing the 2 bolts **D** anchoring the motor to the plate.

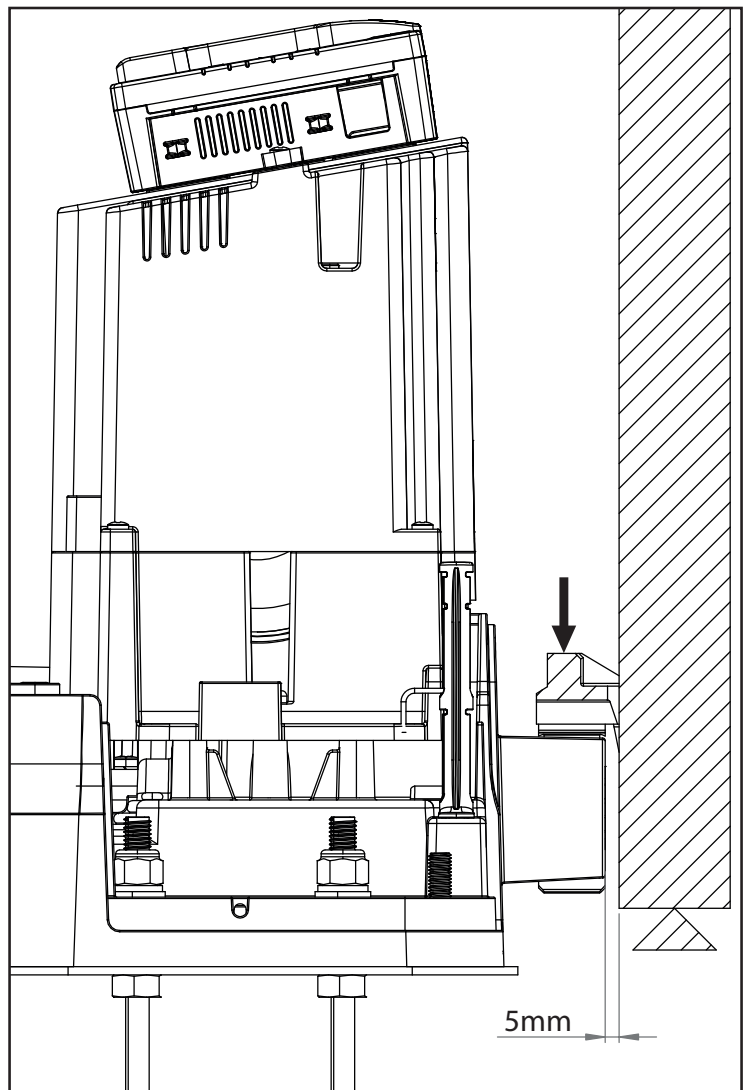

### 3.4 - INSTALLING THE MAGNETIC LIMIT SWITCHES

**⚠ WARNING:** For your safety, it is necessary that the gate is equipped with mechanical stoppers. If the gate is not equipped with these stoppers, an erratic movement past the range limit may cause the gate to fall.

Slide the gate leaf open by hand, stopping it 2/3 before the mechanical stop.

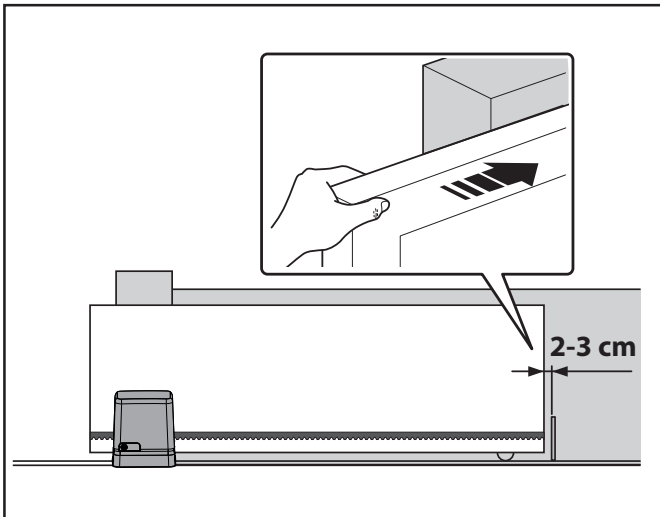

Apply the limit switch bracket **L** to the rack as close as possible to the sensor **M** and fasten it with the appropriate grub screws.

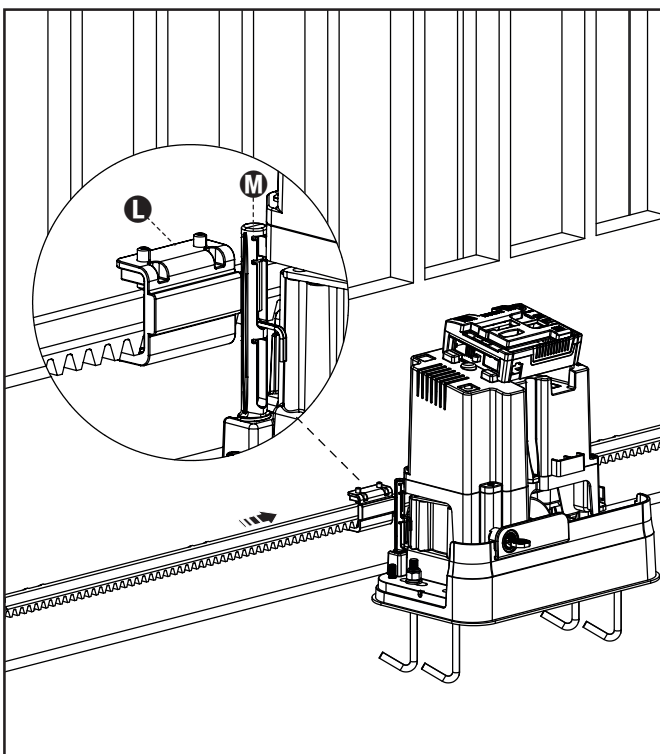

Manually close the gate leaf leaving it 2/3 cm from the mechanical stop and repeat the operations described above to fasten the limit switch bracket.

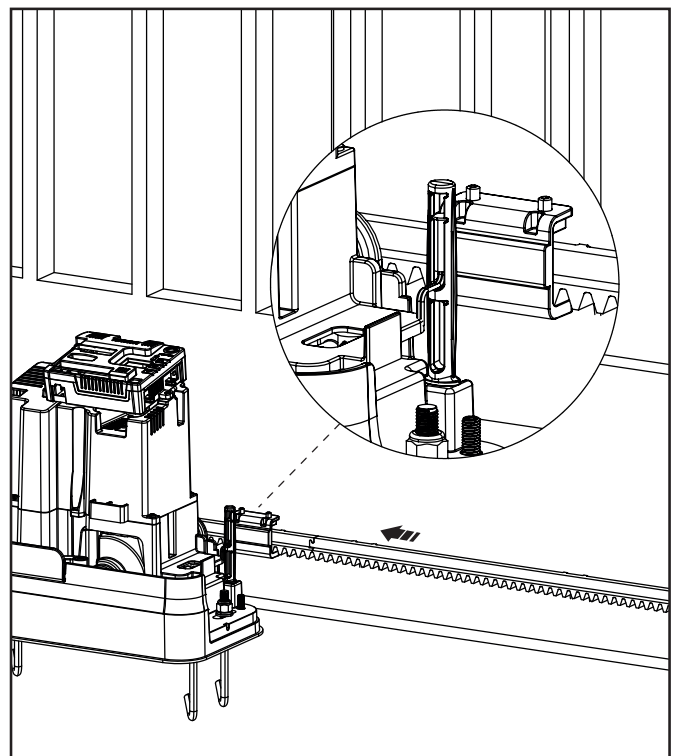
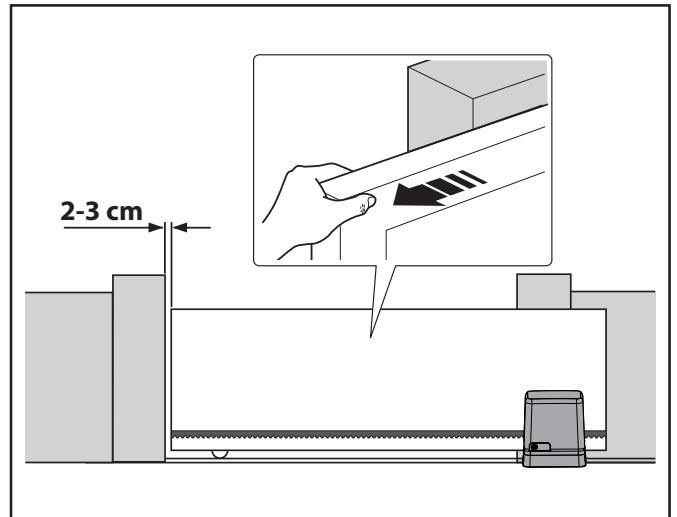

### 3.5 - MOTOR OVERRIDING SYSTEM

The gearmotor is equipped with a mechanical unlocking system that allows for opening and closing the gate manually.

These manual operations should only be performed in case of a power outage, malfunctions or during the installation phases.

To unlock the device:

1. Open the locking hook using the key provided
2. At this point, the automation can be moved manually to the desired position.
3. To lock the gate, close the locking hook, turn the key anti-clockwise and remove it.

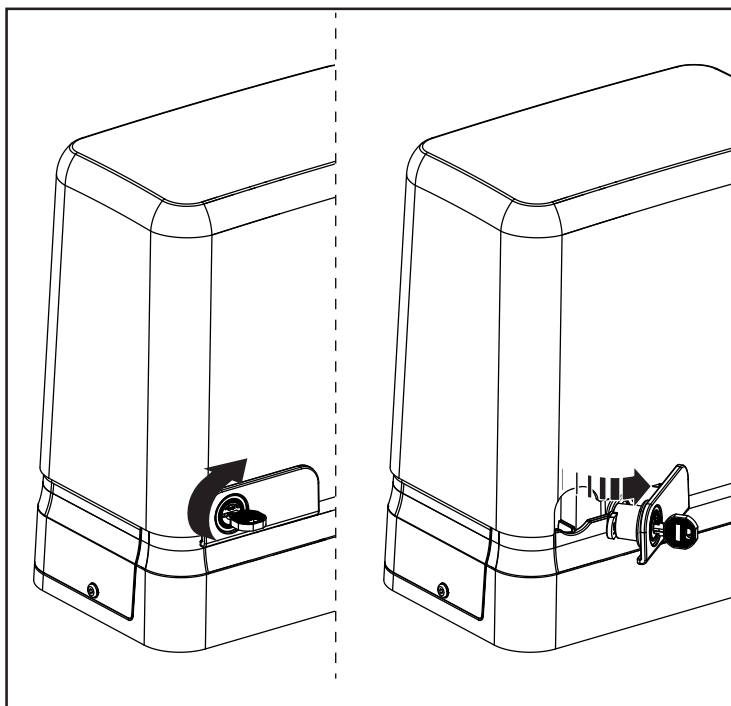

### 3.6 - INSTALLATION LAYOUT

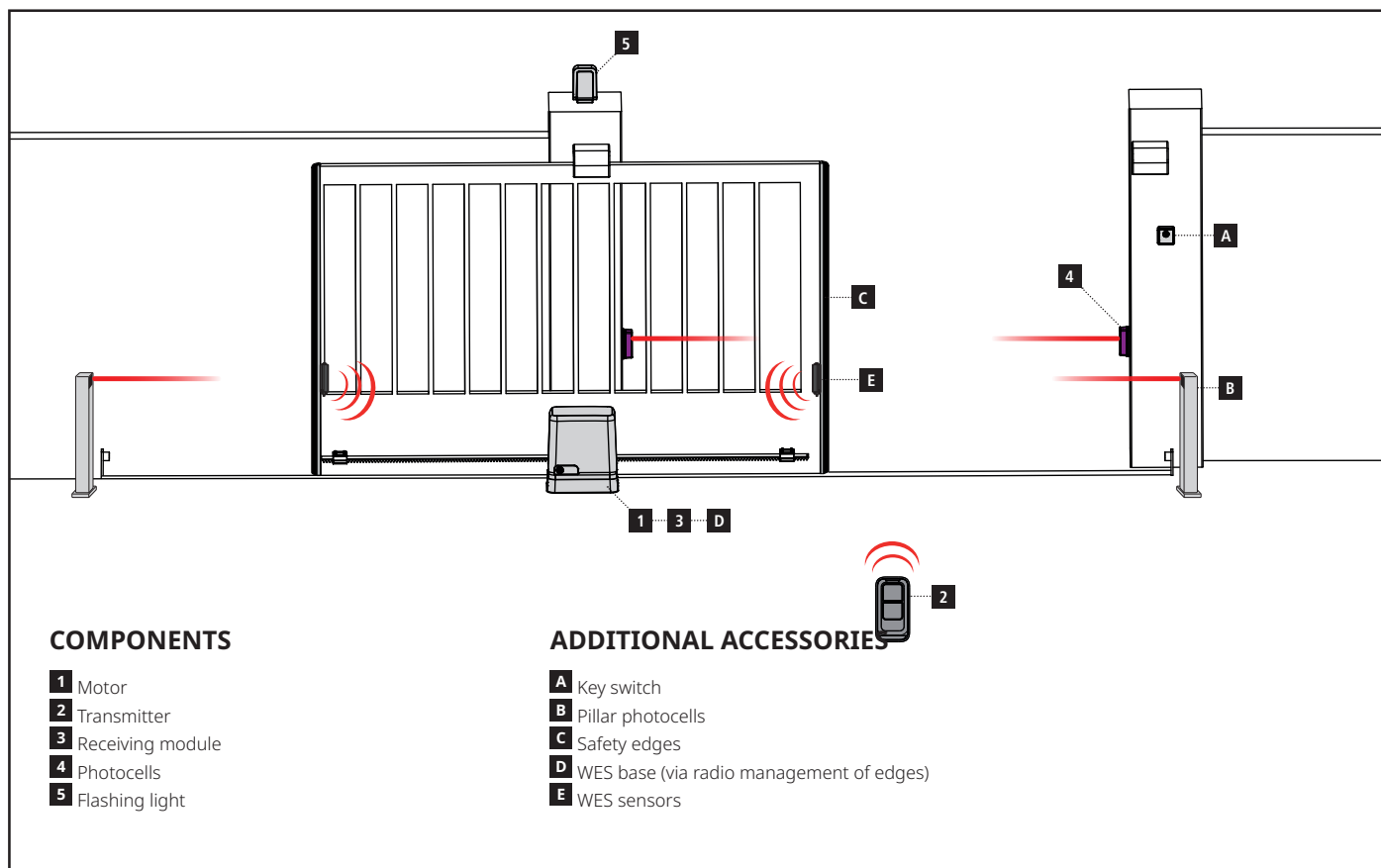

LENGTH OF THE CABLE	< 10 metres	from 10 to 20 metres	from 20 to 30 metres
Power supply 230V	3G x 1,5 mm <sup>2</sup>	3G x 1,5 mm <sup>2</sup>	3G x 2,5 mm <sup>2</sup>
Photocells (TX)	2 x 0,5 mm <sup>2</sup>	2 x 0,5 mm <sup>2</sup>	2 x 0,5 mm <sup>2</sup>
Key switch	4 x 0,5 mm <sup>2</sup>	4 x 0,5 mm <sup>2</sup>	4 x 0,5 mm <sup>2</sup>
Photocells (RX)	2 x 0,5 mm <sup>2</sup>	2 x 0,5 mm <sup>2</sup>	2 x 0,5 mm <sup>2</sup>
Flashing light	2 x 1,5 mm <sup>2</sup>	2 x 1,5 mm <sup>2</sup>	2 x 1,5 mm <sup>2</sup>
Antenna (integrated into the flashing light)	RG174	RG174	RG174

## 4 - CONTROL UNIT

KB25 is provided with a display that, not only makes programming simple, but also allows a continuous monitoring of the input statuses; in addition, thanks to a menu structure, the working schedule and the operation logic can be set easily.

In compliance with the European standards concerning electrical safety and electromagnetic compatibility it has been equipped with the low voltage circuit total electric insulation (motors included) from the network voltage.

Other characteristics:

- Automatic learning of the limit switch position
- Tests for safety devices (photocells, safety ribbons and mosfet) before each opening
- Deactivation of safety inputs through the configuration menu: no jumper is required for terminals concerning safety devices that have not been installed, yet. You will only need to disable this function from its relevant menu
- Automatic shutdown of all peripherals when the control unit is not operating the gate, to keep the power absorbed in stand-by below 500 mW.
- Synchronized operation of two motors using the SYNCRO optional module
- The device can operate without mains power, by using the optional battery pack (code 16Y016).

 **Installation of control unit and safety devices must be carried out with power disconnected.**

### 4.1 - POWER SUPPLY

The control unit must be fed by a 230V - 50Hz electric line, protected by a differential magnetothermal switch complying with the law provisions in force.

Connect power supply cables to terminals **L** and **N** of KB25 control unit.

### 4.2 - FLASHING LIGHT

The KB25 control unit requires the use of a 24V flashing light with a maximum load of 10W, no internal flashing is required.

Connect Flashing light cables to terminals **Z5 (+)** and **Z4 (-)** of the control unit.

### 4.3 - COURTESY LIGHTS

Thanks to the output COURTESY LIGHT the control unit allows the connection of an electric appliance (e.g. courtesy light or garden lights), controlled automatically or by means of the special transmitter key.

The output COURTESY LIGHT is a simple N.O. contact with no power supply.

Connect the cables to terminals **B1** and **B2**.

## 4.4 - ACTIVATION INPUTS

KB25 control unit is equipped with two activation inputs (START and START2), whose operation depends on the programmed operation modes (see **Start** item of programming menu):

### Standard mode

START = START (a command will cause the complete opening of the gate)

START2 = PEDESTRIAN START (a command will cause the partial opening of the gate)

### Open/Close command

START = OPENING (always controls the gate opening)

START2 = CLOSING (always controls the gate closing)

This is an impulse command, that is to say that an impulse will cause the complete gate opening or closing.

### Manned operation

START = OPENING (always controls the gate opening)

START2 = CLOSING (always controls the gate closing)

This is a monostable command, that is to say, the gate will be opened or closed as long as the contact is closed and it will immediately stop as the contact is open

### Mode with presence or fire sensor

In this mode, the PEDESTRIAN START input can be used to connect a maintained command device, such as a presence detector, a magnetic loop or a fire sensor.

Closing the contact causes the gate to open immediately and completely (or reopen if the gate is closing), and closing is no longer possible until the contact opens.

Depending on the option chosen in the **Start** menu, you can have normal operation, suitable for presence detectors, or emergency operation, for the fire sensor; in the first case, the opening is subject to all the controls of a normal opening, and if automatic re-closing is programmed, when the contact reopens the gate closes automatically; in the second case only the checks that could have consequences on safety are carried out, and a start command is necessary to close the gate once the alarm is over.

In both modes, the START input starts the cycle as in standard mode.

**ATTENTION! If the device that controls the opening must be powered by the control unit, terminal J3 (+24V) and J4 (COM) must be used, so that the power supply is available even when the control unit is in stand-by.**

### Timer mode

This feature allows you to program time slots during the day for the gate to be open by using an external timer or other maintained command devices (e.g. magnetic loop detectors or presence detectors).

START = START (a command will cause the complete opening of the gate)

START2 = PEDESTRIAN START (a command will cause the partial opening of the gate)

The gate stays open (completely or partially) while the contact is closed on input; as soon as the contact is open the pause time count down will start, after which the gate will be closed again.

### ATTENTION: Automatic closing must be enabled

**NOTE:** If the parameter **P.RPP = 0** the timer connected to START2 does not cause the opening, but can inhibit the automatic closing at preset times.

In all modes, inputs must be connected to devices having normally open contacts.

Connect cables of device controlling the START input between terminals **J1** (START) and **J4** (COM) of the control unit.

Connect cables of device controlling the START2 input between terminals **J2** (START2) and **J4** (COM) of the control unit.

The START input function can also be activated by pressing **^** key (outside the programming menu) or by means of a remote control stored on channel 1 of MR receiver.

The START2 input function can also be activated by pressing **✓** key (outside the programming menu) or by means of a remote control stored on channel 2 of MR receiver.

## 4.5 - STOP

For a better safety, you can fit a stop switch that will cause the immediate gate stop when activated. This switch must have a normally close contact that will get open in case of operation.

In case the stop switch is operated while the gate is open, the automatic closing function will always be disabled. To close the gate again, you will need a start command.

The stop switch shares the input terminal with the sensitive edges; if you use this switch you must give up one of the two types of sensitive edges.

Connect the STOP switch cables between terminals **J7** (or **J8**) and **J9** of the control unit.

**ATTENTION! If terminal J7 or J8 is used for a stop command, the control unit always considers it a normally closed input, regardless of the parameter setting  $\text{C}\alpha.\text{E}$ .**

The STOP switch function can be activated by means of a remote control stored on channel 3 of MR receiver.

## 4.6 - PHOTOCELLS

The control unit considers two kinds of photocells, depending on the terminal to which they are connected:

### Photocell 1

Photocells installed on the gate inner side, which are active both during the opening and the closing phase. When photocells 1 operate, the control unit stops the gate; as soon as the photocell beam is free, the control unit will open the gate completely.

 **WARNING: Type 1 photocells must be installed so that they completely cover the opening area of the gate.**

### Photocell 2

Photocells installed on the external gate side and which are active during the closing phase only. When photocells 2 operate, the control unit opens the gate immediately, without waiting for release.

KB25 control unit supplies a 24 Vdc power supply to photocells and it can perform a photocell operation test before starting the gate opening phase. Photocell power terminals are protected by an electronic fuse that stops current in case of overload.

- Connect power supply cables of photocells transmitter between terminals **Z2 (-)** and **Z3 (+)** of the control unit.
- Connect power supply cables of photocells receiver between terminals **Z1 (+)** and **Z2 (-)** of the control unit.
- Connect receiver output of photocells 1 between terminals **J5** and **J9** of the control unit and receiver output of photocells 2 between terminals **J6** and **J9** of the control unit.  
Use outputs having normally closed contact.

 **ATTENZIONE:**

- If several couples of same kind photocells are mounted, their outputs must be connected in series.
- In case of reflection photocells, power supply must be connected to terminals **Z2** and **Z3** of the control unit to carry out the operation test.

## 4.7 - SAFETY RIBBONS

The control unit considers two kinds of safety ribbons, depending on the terminal to which they are connected:

### Type 1

When type 1 safety ribbons operate during the gate opening phase, the control unit will close the doors for 3 seconds, then it stands still; when type 1 safety ribbons operate during the gate closing phase, the control unit will stand still immediately. The direction of the gate at next command of START or PEDESTRIAN START depends upon the parameter STOP (it inverts or continues the motion). If the input STOP is disabled, the command makes the motion continue in the same direction.

### Type 2

when type 2 safety ribbons operate during the gate opening phase, the control unit will stand still immediately; when type 2 safety ribbons operate during the gate closing, the control unit will open the doors for 3 seconds, then it will stand still. The direction of the gate at next command of START or PEDESTRIAN START depends upon the parameter STOP (it inverts or continues the motion). If the input STOP is disabled, the command makes the motion continue in the same direction.

Both the input can manage the classic safety edge with n.c. contact and the conductive rubber safety edge with 8,2 kohm nominal resistance.

Connect type 1 safety ribbons cables between terminals **J7** and **J9** of the control unit.

Connect type 2 safety ribbons cables between terminals **J8** and **J9** of the control unit.

In order to meet the requirements of the EN12978 rules, it is necessary to install safety edges controlled by a control unit continuously checking the proper working. If using control units suited to the test by power outage, connect the power supply cables of the control unit between terminals **Z3 (+)** and **Z2 (-)** of the control unit.

Otherwise, connect them between terminals **Z1** and **Z2**.

### WARNING:

- Make use of safety ribbons having outputs with normally close contact.
- Outputs of same kind safety ribbons must be connected in series.

## 4.8 - EXTERNAL AERIAL

We suggest to use the external aerial (model: ANS433) in order to guarantee the maximal range.

Connect the antenna hot pole to terminal **A2** of the control unit and the braiding to terminal **A1**.

## 4.9 - ELECTRICAL CONNECTION

<b>A1</b>	Antenna shield
<b>A2</b>	Antenna

<b>J1</b>	START - Open command for connecting traditional devices with N.O. contact
<b>J2</b>	START2 - Pedestrian open command for connecting traditional devices with N.O. contact
<b>J3</b>	24Vdc power supply for activation devices available even when the control unit is in stand-by (24V ± 15% / 3W)
<b>J4</b>	Common (-)
<b>J5</b>	Photocell 1. N.C. contact
<b>J6</b>	Photocell 2. N.C. contact
<b>J7</b>	Type 1 edges or STOP. N.C. contact
<b>J8</b>	Type 2 edges or STOP. N.C. contact
<b>J9</b>	Common (-)

<b>Z1</b>	24 Vdc power output for photocells and other accessories which are turned off during stand-by
<b>Z2</b>	Accessory power common (-)
<b>Z3</b>	24 Vdc supply - photocell/optical edge TX for functional Test. Connect power supply cables of photocells transmitter between terminals Z2 and Z3
<b>Z4 - Z5</b>	Flashing light 24Vdc
<b>Z6</b>	NOT USED

<b>B1 - B2</b>	Courtesy light
----------------	----------------

<b>L</b>	Power phase 230 Vac
<b>N</b>	Neutral 230 Vac

<b>ADI</b>	ADI module interface
<b>RECEIVER</b>	Plug-in receiver
<b>FUSE</b>	F5A - 250V
<b>OVERLOAD</b>	Signaling of overload or short circuit on the accessory power supply

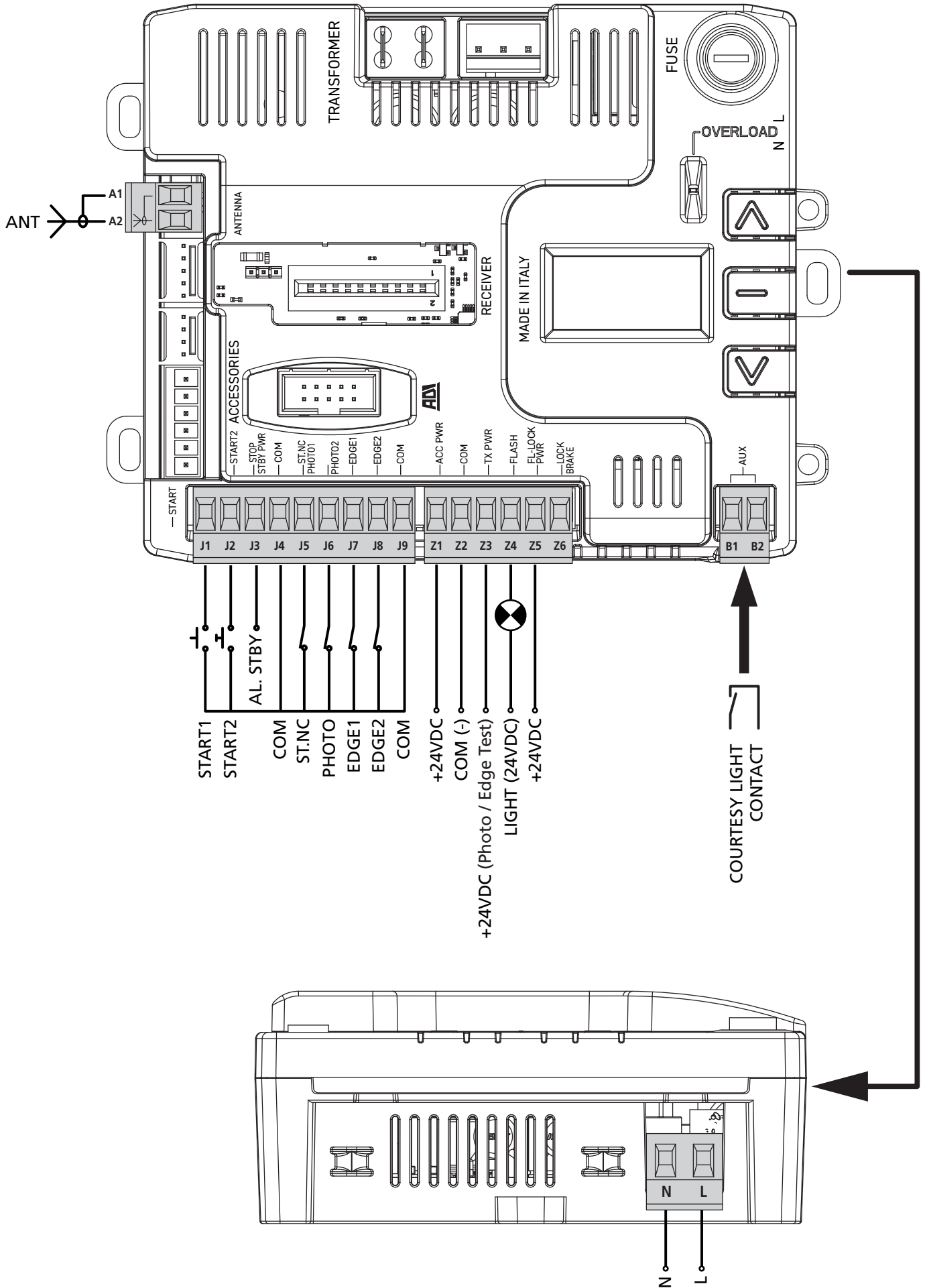

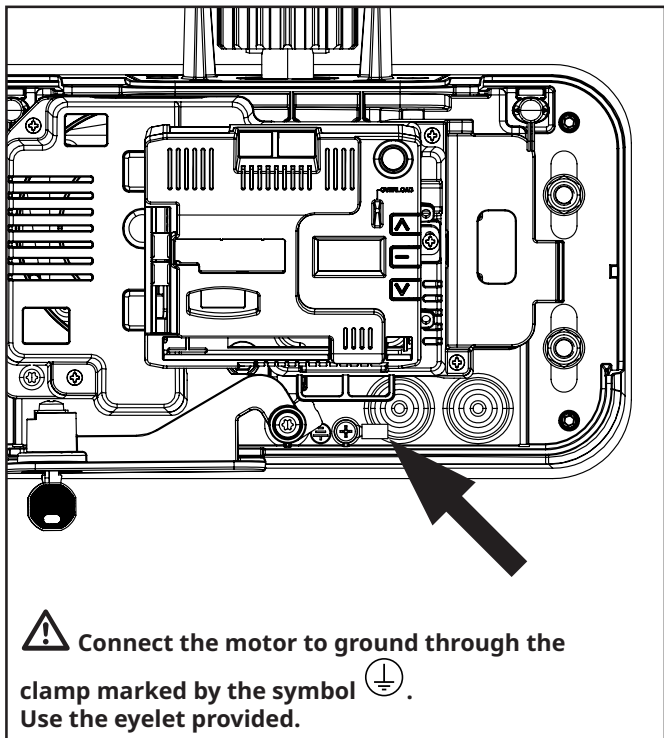

#### 4.10 - CONNECTING AND INSTALLING THE BACKUP BATTERY

**⚠** The electrical connection of the battery to the control unit must be made only after completing all the installation and programming stages, as the battery is an emergency power supply.

**⚠** Before installing a back-up battery, disconnect the power supply to the control unit.

Place the battery (code 16Y016) in the appropriate housing and connect to the control unit with the supplied cable.

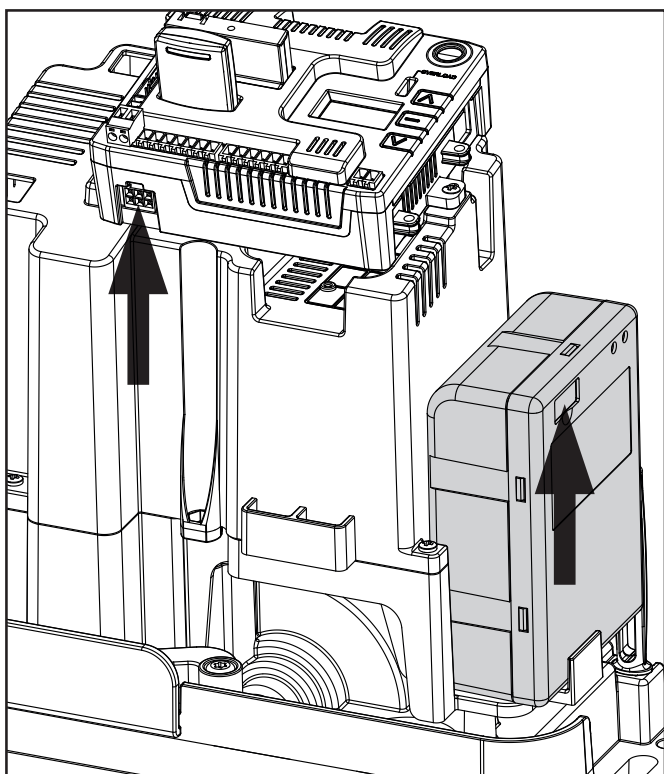

#### 4.11 - PLUG IN RECEIVER

KB25 control unit is suitable for plugging in a MR receiver having a high-sensitivity super-heterodyne architecture.

**⚠ WARNING: Pay attention to the way you connect the removable modules.**

MR module receiver is provided with 4 channels and each of them is suitable for a command of KB25 control unit:

- CHANNEL 1 → START
- CHANNEL 2 → PEDESTRIAN START
- CHANNEL 3 → STOP
- CHANNEL 4 → COURTESY LIGHT

**NOTE: Before programming 4 channels and function logics read carefully the instructions of MR.**

#### 4.12 - ADI INTERFACE

The ADI (Additional Devices Interface) interface of the control unit KB25 allows the connection to V2 optional modules.

Refer to V2 catalogue or to the technical sheets to see which optional modules with ADI interface are available for this control unit.

**⚠ WARNING: Please read the instructions of each single module to install the optional modules.**

For some devices, it is possible to configure the mode for interfacing with the control unit; in addition, it is necessary to enable the interface so that the control unit can process the signals arriving from the ADI device.

Please refer to the **Adi** programming menu to enable the ADI interface and access the device configuration menu. ADI devices use the display of the control unit to issue alarms or display the configuration of the device.

The device connected to the Adi interface is able to signal to the control unit three alarm signals, which are displayed on the control unit display as follows:

- PHOTOCELL ALARMS - the upper segment comes on: the gate stops moving, when the alarm stops opening restarts.
- EDGE ALARM - the lower segment comes on: inverts motion of the gate for 3 seconds.
- STOP ALARM - both segments start flashing: the gate stops and cannot restart until the alarm stops.
- SLAVE - segment steadily lit: it is used by the optional module SYNCRO to indicate that the control unit is configured as SLAVE.

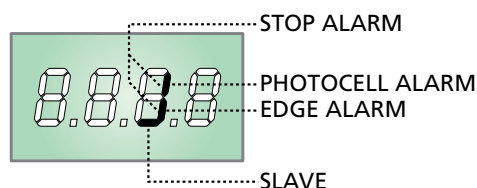

## 5 - CONTROL PANEL

### 5.1 - DISPLAY

When power is on, the control unit checks that display correctly operates by switching on all segments for 1 sec. 8.8.8.8.

In the next second, the software version of the control panel is indicated (baptism) SL 6.

Firmware version, e.g. Pr 1.0, will be viewed in the following 2 sec.

Panel will be viewed upon completion of this test.

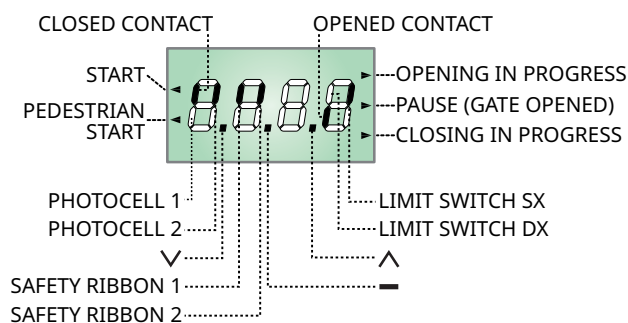

The control panel represents the physical status of the terminal board contacts and of the program mode keys: if the upper vertical segment is on, the contact is closed; if the lower vertical segment is on, the contact is open (the above picture shows an instance where the inputs PHOTO1, PHOTO2, EDGE1 and EDGE2 have all been correctly connected).

**NOTE: when the control unit is in stand-by, the status of the inputs is undefined and is not shown on the display. Only the status of the activation inputs (left arrow) and any pause status (right arrow) is displayed.**

**NOTE: if you are using an ADI module, other segments may appear on the display, see the paragraph dedicated to the "ADI INTERFACE"**

Points being among display digits show the status of programming push-buttons: as soon as a push-button is pressed, its relevant point turns on.

The arrows on the left of the display show the state of the start inputs. The arrows light when the related input is closed.

The arrows on the display right side show the gate status:

- The highest arrow turns on when the gate is into its opening phase. If it blinks, it means that the opening has been caused by a safety device (border or obstacle detector).
- The central arrow shows that the gate is on pause. If it blinks, it means that the time countdown for the automatic closing has been activated.
- The lowest arrow blinks when the gate is into its closing phase. If it blinks, it means that the closing has been caused by a safety device (border or obstacle detector).

## 5.2 - USE OF THE KEYS FOR PROGRAMMING

The control unit functions and times are programmed by means of a special configuration menu, which can be accessed and explored by using the 3 keys, **▲ ▼ ▬**, located on the side of the control unit display.

**PLEASE NOTE: Outside the configuration menu, pressing the ▲ key activates the START command, pressing the ▼ key activates the PEDESTRIAN START command.**

There are the following three kinds of menu items:

- Function menu
- Time menu
- Value menu

### Function menu setup

Function menus allow selecting a function from among a group of available options. When you enter into a function menu, the current active option will be viewed; you can scroll all available options through **▼** and **▲** keys. By pressing the **▬** key, you will activate the option viewed and you will return to the configuration menu.

### Time menu setup

Time menus allow setting a function duration. When you enter into a time menu, the current setup value will be viewed; the display mode depends on the current value:

- Each time you press **▲** key, current time value increases and each time you press the **▼** key, current time value decreases.
- By holding down the **▲** key, you can quickly increase the time value, up to reach the max. value allowed for this item.
- Vice versa, by holding down the **▼** key, you can quickly decrease the time value down to reach **0.0"**
- In some circumstances, setting the value to **0** means that the relevant function is disabled, in this case, **no** will appear instead of **0.0"**
- By pressing on **▬** you will confirm the displayed value and you will return to the configuration menu.

### Value menu setup

Value menus are similar to time menus; however, the setup value can be any number.

By holding down **▲** or **▼** keys, the value will increase or decrease slowly.

By pressing on **OK** you will confirm the displayed value and you will return to the configuration menu.

The main programming menus of the control unit are shown in the next pages.

To go through the menus use the three keys **▲ ▼ ▬** according to the following chart:

	Press and release the push-button <b>▬</b>
	Keep pressed the push-button <b>▬</b> for 2 seconds
	Release the push-button <b>▬</b>
	Press and release the push-button <b>▲</b>
	Press and release the push-button <b>▼</b>

## 6 - ACCESSING THE CONTROL UNIT SETTINGS

1. Press and hold the **—** key until the display shows the menu desired
2. Release the **—** key: the display will show the first item in the sub-menu
  - **PrG** Programming the control unit (chapter 12)
  - **Cnt** Cycle counter (chapter 11)
  - **RPP** Self-learning of working times (chapter 9)
  - **dEF** Loading the default parameters (chapter 9)

**⚠ WARNING: in case no operation is carried out for more than one minute, the control unit exits from the programming mode without saving any of your setups and changes, which will get lost.**

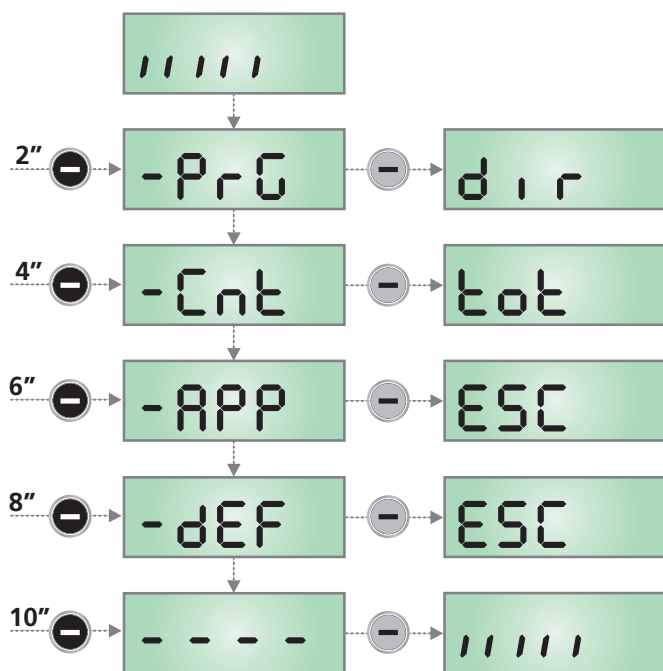

## 7 - QUICK CONFIGURATION

This paragraph concerns a quick procedure to set the control unit and set it at work immediately.

**We recommend following these instructions, in order to check quickly the correct operation of control unit, motor and accessories, and then changing the configuration in case of any non-satisfactory parameter.**

1. Call up the default configuration: see chapter 8
2. Set items
  - dir - Fot1 - Fot2 - CoS1 - CoS2** according to the safety devices installed on the gate.
 For the position of the item menus inside the main menu and for the options related to each item menu, refer to the chapter 12.
3. Start the self-learning cycle: see chapter 9 (SELF-LEARNING OF WORKING TIMES)
4. Check that the automation work properly and if necessary modify the configuration of the desired parameters.

## 8 - LOADING THE DEFAULT PARAMETERS

If necessary, it is possible to restore all parameters to their standard or default values (see the final summary table).

**⚠ PLEASE NOTE: This procedure results in the loss of all customised parameters.**

1. Press and hold the **—** key until the display shows **-dEF**
2. Release the **—** key: the display shows **ESC** (only press the **—** key if it is desired to exit this menu)
3. Press the **▼** key: the display shows **dEF**
4. Press the **—** key: the display shows **no**
5. Press the **▼** key: the display shows **S<sub>1</sub>**
6. Press the **—** key: all parameters are overwritten with their default values (see Chapter 12), the control units exits programming mode and the display shows the control panel.

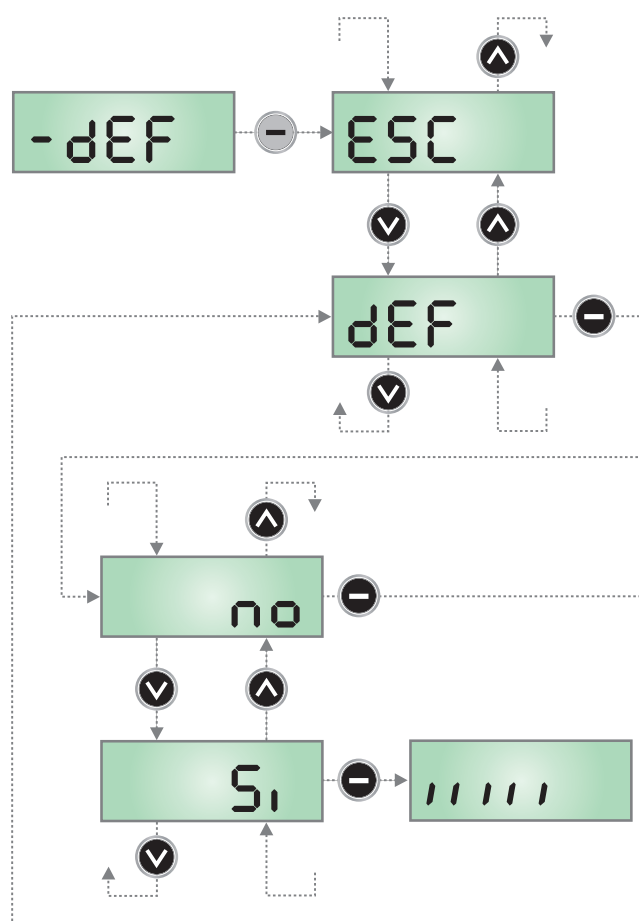

## 9 - SELF-LEARNING OF WORKING TIMES

This menu allows the automatic learning of the times necessary to open and close the gate.

**⚠ CAUTION:** to perform the self-learning procedure it is necessary to disable the ADI interface by means of the menu `ADI`.

If some safeties are controlled by means of the ADI module, they will not be active during the self-teaching stage.

**⚠ CAUTION: ATTENTION:** before proceeding, make sure to position the mechanical stops and the limit sensors correctly.

Position the gate halfway and proceed as follows:

1. Press and hold the **—** key until the display shows **-APP**
2. Release the button **—** and select the type of learning you wish to perform using the buttons **∇** e **▲**:

**ESC** no learning is performed. Pressing the button **—** returns to normal operation

**ε.LAu** position learning: the gate performs a cycle at reduced speed (**Po.AL** parameter) to acquire the limit switch positions. The procedure will take place as follows:

- a. The gate is activated in closing until the limit switch is reached.
- b. The gate is activated in opening until the limit switch is reached.
- c. The gate is activated in closing until the limit switch is reached.

**AMP** learning efforts: the gate performs a cycle at normal speed to acquire the currents and stores the values of **SEn.A** and **SEn.C**

**SMA** learning positions + efforts: the gate first executes the learning positions cycle and then the learning efforts cycle

3. Press the button **—** to start the self-learning cycle: the display shows the control panel and the time self-learning procedure begins.

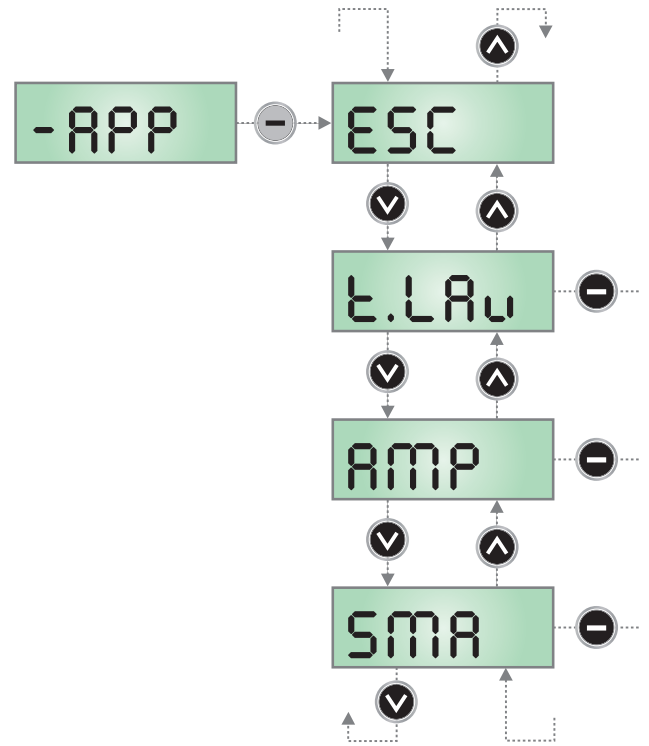

## 10 - EMERGENCY DEAD MAN OPERATION

This operational mode can be used to move the gate in DEAD MAN mode in case of malfunctioning of photocell, edge, limit switches or encoder.

To activate the function the START command must be pressed 3 times (presses must last at least 1 second; the pause between commands must last at least 1 second).

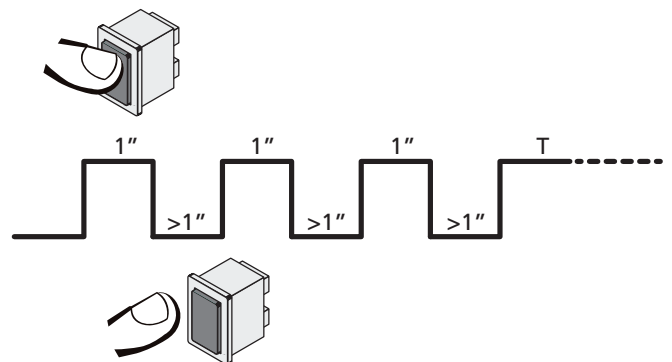

The fourth START command activates the gate in MAN PRESENT mode. To move the gate keep the START command pressed for the duration of the operation (time T). The function will automatically turn off after 10 seconds of inactivity of the gate.

**NOTE:** if the **SErε** parameter is set as **SEAn**, the Start command (from the terminal block or remote control) moves the gate in the open and closed directions alternatively (unlike the normal DEAD MAN mode).

## 11 - READING THE COUNTER OF THE CYCLES AND EVENTS MEMORY

KB25 control unit counts the completed opening cycles of the gate and, if requested, it shows that service is required after a fixed number of cycles.

Furthermore, events can be recorded which occurred during operation, associating to each a code and a date/time in which each occurred; this information must be communicated to the support service if problems arise.

**ATTENTION: the correct date/time information of an event is stored only if the information is supplied to the control panel by a device equipped with a clock, such as the WiFi interface.**

There are 3 counters available:

- A totalizing counter for completed opening cycles that cannot be zeroed (option **tot** of item **Cnt** )
- A downward counter for the number of cycles before the next request for service (option **Seru** of item **Cnt** ).

When the counter of missing cycles for the next maintenance intervention reaches zero, the control unit signals the maintenance request by means of an additional pre-flashing of 5 seconds. The signal is repeated at the beginning of each opening cycle, until the installer accesses the meter reading and setting menu, possibly programming the number of cycles after which maintenance will be required again. If a new value is not set (i.e. the counter is left at zero), the maintenance request signaling function is disabled and the signaling is no longer repeated.

- Events counter (option **EuEn**)

The scheme hereafter shows how to read the totalizing counter, how to read the number of cycles before the next service is required as well as how to program the number of cycles before the next request for service (as for the example shown, the control unit completed no. 12451 cycles and there are no. 1300 cycles before the next service request; the code of the last recorded event is 176, and it occurred at 14.14.19 on 20 August.

**Area 1** is the reading of the total number of completed cycles; through **▼** and **▲** keys, you can alternate the display of thousands or units.

**Area 2** is the reading of the number of cycles before the next request for service: its value is rounded down to the hundreds.

**Area 3** represents the setting of this counter: on first pressing of the key **▼** or **▲** the current value of the counter, it is rounded off to the thousand, every subsequent press increases the setting by 1000 units or decreases by 100. The previously displayed count is lost.

**Area 4** represents reading of the events memory.

The first data is an index that allows identification of the event: **n 1** is the last event recorded, **n 2** is the previous one and so on.

The other data are automatically displayed in succession and provide information on the date/time (each data remains displayed for approximately one second, if you want to temporarily stop the display, keep the MENU key pressed); the last data displayed is the code of the event (in some cases, after the event code additional data is displayed), then the sequence restarts from the index.

The data are displayed for 1 minute, after which the display returns to normal view.

All events with their meaning can be viewed in the table available at the following link

### **EVENTS TABLE**

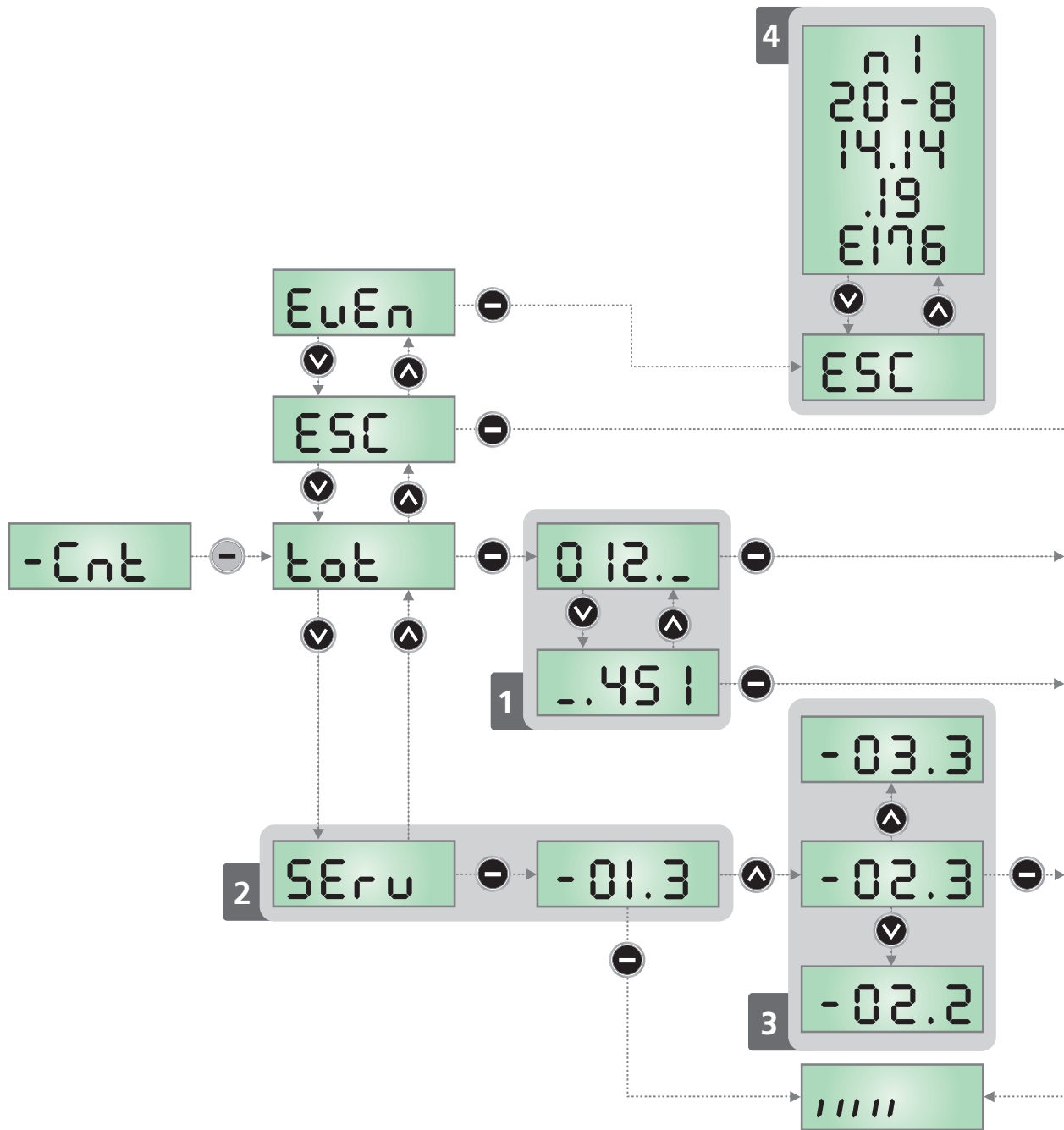

## 12 - PROGRAMMING THE CONTROL UNIT

The configuration menu **-PrG** consists in a list of configurable items; the display shows the selected item.

By pressing **▼**, you will pass to the next item; by pressing **▲**, you will return to the previous item.

By pressing **←**, you can view the current value of selected item and possibly change it.

The last menu item (**FinE**) allows storing the carried out changes and going back to the control unit normal operation.

You must exit from programming mode through this menu item if you do not want to lose your configuration.

**⚠ WARNING: in case no operation is carried out for more than one minute, the control unit exits from the programming mode without saving any of your setups and changes, which will get lost.**

By holding down the **▼** or **▲** keys, configuration menu items will scroll fast, until item **FinE** is viewed.

In this way, you can quickly reach either the top or bottom of the list.

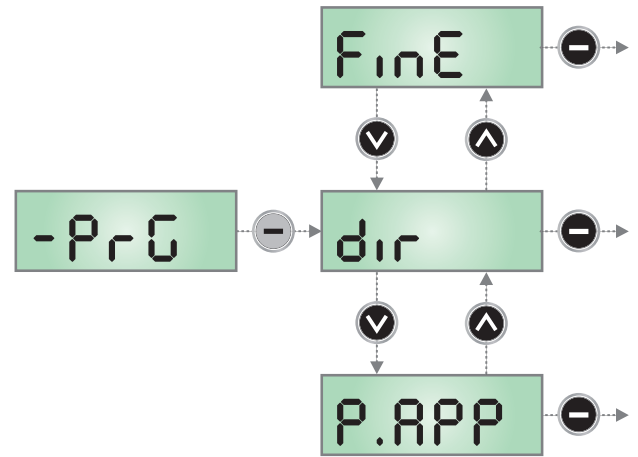

PARAMETER	VALUE	DESCRIPTION	DEFAULT
<b>dir</b>		<b>Gate direction (the direction you see from the inside)</b>	<b>d]C</b>
	d]C	The gate opens rightwards	
	S]C	The gate opens leftwards	
<b>P.APP</b>		<b>Partial opening</b>	<b>25</b>
	0 - 100	The percentage of the path the gate performs in the case of opening using the Pedestrian Start command	
<b>t.PrE</b>		<b>Pre-blinking time</b>	<b>1.0"</b>
	0.5" - 1'00	Before any gate movement, blinker will be activated for <b>t.PrE</b> time, to warn about the incoming motion (adjustable time from 0.5" to 1'00)	
	no	Function deactivated	
<b>t.PCh</b>		<b>Different closing pre-flashing time</b>	<b>no</b>
	0.5" - 1'00	If this parameter has a value assigned to it, the control unit will activate pre-flashing prior to closure for the length of time set in this menu (adjustable time from 0.5" to 1'00)	
	no	The closing pre-flashing time corresponds to <b>t.PrE</b>	
<b>PoE</b>		<b>Motor power</b>	<b>80</b>
	35 - 100	The displayed value is the percentage of max. motor power	
<b>P.rAL</b>		<b>Engine power during the slowdown phase</b>	<b>20</b>
	0 - 70	The displayed value represents the percentage of the maximum engine power	
<b>Po.AL</b>		<b>Power used for realignment on the limit switch</b>	<b>30</b>
	0 - 70	Power used in searching for the position of the limit switch, in the self-learning phases or after the reset	

PARAMETER	VALUE	DESCRIPTION	DEFAULT
SPUn		<b>Start off</b>	Si
	Si - no	If this function is activated, for the first 2 seconds of motion of each door, the control unit will ignore P <sub>oE</sub> value and it will give motor the maximum power command in order to overcome the gate inertia	
rRM		<b>Starting ramp</b>	3
	0 - 6	In order not to stress too much the motor, when the motion starts the power is gradually increased, until reached the set value or 100% if the take-off is enabled. Higher is the set value, longer the length of time of the ramp, that is the time necessary to reach the value of nominal power.	
rMd		<b>Deceleration ramp</b>	3
	0 - 6	Allows you to make the transition from cruising speed to slow speed smoother. The higher the set value, the longer the motor is kept off so that the gate can slow down due to inertia	
SEn.A		<b>Adjustment of the opening obstacle sensor</b>	no
	1.0A - 16A	Function disabled	
	no	This menu allows you to adjust the sensitivity of the opening obstacle sensor. When the current absorbed by the motor exceeds the set value, the control unit detects an alarm	
SEn.C		<b>Adjustment of the obstacle sensor during closing</b>	no
	1.0A - 16A	Function disabled	
	no	This menu allows you to adjust the sensitivity of the obstacle sensor during closing. When the current absorbed by the motor exceeds the set value, the control unit detects an alarm	
SEn.u		<b>Speed sensor adjustment</b>	1
	0 - 7	This menu allows you to adjust the sensitivity of the speed sensor (virtual encoder), which determines any stalling. 0 = minimum sensitivity 7 = maximum sensitivity When the sensor intervenes the control unit behaves as if it detected an obstacle.	
rR.AP		<b>Slow down in opening</b>	10
	0 - 100	This menu allows regulating the percentage of the ride/drive that is carried out at reduced speed during the last opening stretch	
rR.Ch		<b>Slow down in closing</b>	10
	0 - 100	This menu allows regulating the percentage of the ride/drive that is carried out at reduced speed during the last closing stretch	
St.AP		<b>Start command during the opening phase</b> This menu allows fixing the control unit conduct in case it receives a Start command during the opening phase	PAUS
	PAUS	The gate stops and goes to pause	
	ChiU	The gate immediately starts closing	
	no	The gate go on with the opening phase (command is ignored)	

PARAMETER	VALUE	DESCRIPTION	DEFAULT
St.Ch		<b>Start command during the closing phase</b> This menu allows fixing the control unit conduct in case it receives a Start command during the closing phase	StoP
	StoP	The gate stops and its cycle is considered as finished	
	RPEr	The gate opens again	
St.PA		<b>Start command during the pause</b> This menu allows fixing the control unit conduct in case it receives a Start command when the gate is open during its pause phase	ChiU
	ChiU	The gate starts closing	
	no	Command is ignored	
	PAUS	The pause time is reset (Ch.AU)	
SP.AP		<b>Pedestrian Start during the partial opening phase</b> This menu allows fixing the control unit conduct in case it receives a Pedestrian Start command during the partial opening phase.  <b>WARNING: a Start command in any phase of partial opening will cause the total opening; the Start Pedestrian command is always ignored during a total opening</b>	PAUS
	PAUS	The gate stops and goes to pause	
	ChiU	The gate immediately starts closing	
	no	The gate goes on with the opening phase (command is ignored)	
Ch.AU		<b>Automatic closing</b> In automatic mode, the control unit automatically recloses the gate on expiry of the time limit set in this menu	no
	no	Function deactivated	
	0.5" - 20.0'	The gate recloses after the set time (adjustable time from 0,5" to 20.0')	
Ch.Er		<b>Closure after passage</b> During the automatic operation, the pause count down starts from the set up value each time a photocell operates during the pause. If the photocell operates during the opening time, this time will be immediately stored as pause time. This function allows having a fast closing as soon as transit through the gate is completed, therefore, a time shorter than Ch.AU is generally used	no
	no	Function deactivated	
	0.5" - 20.0'	The gate recloses after the set time (adjustable time from 0,5" to 20.0')	
PA.Er		<b>Pause after transit</b>	no
	Si	In order to let the gate open for the shortest possible time, it is possible to stop the gate once the passage before the photocells is detected. If the automatic working is enabled, the time of the pause is Ch.Er	
	no	Function deactivated	
LUCi		<b>Luci di cortesia</b> Questo menù permette di impostare il funzionamento delle luci di cortesia in modo automatico durante il ciclo di apertura del cancello	E.LUC
	E.LUC	Funzionamento temporizzato (tempo impostabile da 0 a 20.0')	1'00
	no	Funzione disabilitata	
	CiCL	Luci accese per tutta la durata del ciclo	

PARAMETER	VALUE	DESCRIPTION	DEFAULT
RUS		<b>Canale Ausiliario</b> Questo menù permette di impostare il funzionamento del relè di accensione delle luci di cortesia mediante un telecomando memorizzato sul canale 4 del ricevitore	mon
	t.m	Funzionamento temporizzato (tempo impostabile da 0 a 20.0')	
	b.st	Funzionamento bistabile	
	mon	Funzionamento monostabile	
SP.R		<b>Setting low voltage exit lights</b> This menu makes to possible to set the flashing exit function	FLSh
	FLSh	Flasher operation (fixed frequency)	
	no	Not used	
	W.L.	Indicator light operation: Indicates the status of the gate in real-time. The type of blinking indicates the four possible conditions: - GATE STOPPED: Light off - GATE IN PAUSE: the light is on, fixed - GATE OPENING: the light blinks slowly (2 Hz) - GATE CLOSING: the light blinks quickly (4 Hz)	
LP.PR		<b>Lampeggiatore in pausa</b>	no
	no	Funzione disabilitata	
	Si	Il lampeggiatore funziona anche durante il tempo di pausa (cancello aperto con chiusura automatica attiva).	
St.r.t		<b>Activation inputs function</b> This menu allows selecting input operation modes (see chapter 4.4)	St.Rn
	St.Rn	Standard mode	
	no	Start inputs from terminal board are disabled. Radio inputs operate in standard mode <b>St.Rn</b>	
	St.Fi	Start + fire sensor	
	St.Pr	Start + presence detector or magnetic loop	
	RP.Ch	Open/Close command	
	d.MR	Manned operation	
	oroL	Timer mode	
St.oP		<b>Stop Input</b>	no
	no	The input STOP is not available (ignored by the control unit)	
	ProS	The input STOP stops the gate: pressing the command START the gate continues the motion	
	inuE	The command STOP stops the gate: at the next START the gate starts moving in the opposite direction	
Fo.tI		<b>Photocell 1 input</b> This menu allows enabling the input for type 1 photocells, that is to say, photocells active both during the opening and closing phase	no
	no	Input disabled (ignored by the control unit)	
	RP.Ch	Input enabled	

PARAMETER	VALUE	DESCRIPTION	DEFAULT
FoE2		<b>Photocell 2 input</b> This menu allows enabling the input for type 2 photocells, that is to say, photocells non active during the opening phase	CFCh
	CFCh	Input enabled even at standstill gate too: the opening movement does not start if photocell is interrupte	
	Ch	Input enabled for the closing phase only <b>WARNING: if you select this option, you must disable photocell test</b>	
	no	Input disabled (ignored by the control unit)	
FE.EE		<b>Test of the photocells</b>	no
	no	Function deactivated	
	Si	In order to achieve a safer operation for the user, the unit performs a photocells operational test, before a normal working cycle. If no operational faults are found, the gate starts moving. Otherwise, it will stand still and the flashing light will stay onfor 5 sec. The whole test cycle lasts less than one second.	
CoS1		<b>Safety ribbon 1 input</b> This menu allows enabling the input for type 1 safety ribbon, that is to say, fixed ribbons	no
	no	Input disabled (ignored by the control unit)	
	AP	Input enabled during the opening and disabled during the closure	
	APCh	Input enabled in opening and closure	
	StoP	Activating the input during both opening and closing causes the gate to stop immediately.	
CoS2		<b>Safety ribbon 2 input</b> This menu allows enabling the input for type 2 safety ribbon, that is to say mobile ribbons	no
	no	Input disabled (ignored by the control unit)	
	APCh	Input enabled in opening and closure	
	Ch	Input enabled during closure and disabled during opening	
	StoP	Activating the input during both opening and closing causes the gate to stop immediately.	
Co.EE		<b>Test of the safety edges</b> This menu allows setting the method of control of the safety edges working	no
	no	Test disabled	
	rESi	Test enabled for conductive rubber safety edges	
	FoEo	Test enabled for optical safety edges	

PARAMETER	VALUE	DESCRIPTION	DEFAULT
<b>i.Rd</b>		<p><b>Enabling the ADI device</b> This menu makes it possible to enable operation of the device connected to the ADI connector.</p> <p><b>PLEASE NOTE:</b> selecting <b>S<sub>i</sub></b> and pressing MENU accesses the configuration menu for the device connected to the ADI connector. This menu is managed by the device itself and is different for each device. Please refer to the manual for the device. If the <b>S<sub>i</sub></b> option is selected, but no device is connected, the display will show a series of dotted lines. Exiting the ADI device configuration menu returns to the <b>i.Rd</b> option</p>	<b>no</b>
	<b>no</b>	Interface disabled, any signals will be ignored	
	<b>S<sub>i</sub></b>	Interface enabled	
<b>FinE</b>		<p><b>End of Programming</b> This menu allows to finish the programming (both default and personalized) saving the modified data into memory</p>	<b>no</b>
	<b>no</b>	Do not quit the programming	
	<b>S<sub>i</sub></b>	End of programming	

## 13 - OPERATION DEFECTS

This paragraph shows some possible operation defects, along with their cause and applicable remedy.

Some anomalies are signalled using a message on the display, others with flashing signs or the leds assembled on the control unit.

DISPLAYING	DESCRIPTION	SOLUTION
<b>OVERLOAD led is on</b>	It means that there is an overload on accessory power supply	<ol style="list-style-type: none"> <li>1. Remove the extractable part containing terminals J1 - J9 . OVERLOAD led will switch off.</li> <li>2. Remove the overload cause.</li> <li>3. Reinsert the terminal board extractable part and check that this led is not on again.</li> </ol>
<b>Too long pre-blinking</b>	When a Start command is given and the blinker switches on immediately but the gate is late in opening	It means that the setup cycle count down expired and the control unit shows that service is required
The display shows <b>Err2</b>	When a start command is given the gate won't open. It means that MOSFET test failed.	Before sending the control unit to V2 S.p.A. for repair, be sure that motors have been properly connected.
The display shows <b>Err3</b>	When a start command is given the gate won't open. It means that the photocell test failed.	<ol style="list-style-type: none"> <li>1. Be sure that no obstacle interrupted the photocell beam when the Start command was given.</li> <li>2. Be sure that photocells, as enabled by their relevant menus, have been installed actually.</li> <li>3. If you have photocells 2, be sure that <b>Foot2</b> menu item is on <b>CF.Ch</b>.</li> <li>4. Be sure that photocells are powered and working: interrupt the ray and check that the photocell segment on the display changes position.</li> </ol>
The display shows <b>Err4</b>	When a Start command is given and the gate does not open	<p>This anomaly can occur when in one of the following conditions:</p> <ol style="list-style-type: none"> <li>1. If a START command is sent with the motor released.</li> <li>2. During the self-learning cycle if there are any problems with the range limits. If the magnets are installed correctly, it means that the limit switch sensor is damaged or the cabling connecting the sensor to the central control unit is broken/damaged. Change the end of stroke sensor or the broken wiring.</li> <li>3. During normal operation. If the error persists send the control unit to V2 S.p.A. for repair.</li> </ol>

DISPLAYING	DESCRIPTION	SOLUTION
The display shows <b>Err5</b>	When a start command is given the gate won't open. It means that the test of the safety edges failed.	<ol style="list-style-type: none"> <li>1. Make sure that the menu relative to the test of the facets for cables (<b>Co.EE</b>) is configured correctly.</li> <li>2. Make sure that the safety edges enabled by menu are actually installed.</li> </ol>
The display shows <b>Err6</b>	The MOSFET verification circuit is faulty	Contact the V2 technical assistance service to send the control unit for repair
The display shows <b>Err8</b>	When executing a self-learning function the control is refused. It means that the setting of the control unit is not compatible with the requested function.	<ol style="list-style-type: none"> <li>1. Check the Start inputs are enabled in standard mode (<b>Start</b> menu set on <b>Start</b>).</li> <li>2. Check the ADI interface is disabled (<b>ADI</b> menu set to <b>no</b>).</li> </ol>
The display shows <b>Err9</b>	It means that programming was locked by means of the programming lock key CL1+ (code 161213).	To change the settings it is necessary to insert in the connector of the ADI interface the same key used to activate the programming lock, and unlock the device.
The display shows <b>Er10</b>	When a start command is given the gate won't open. This means that the ADI module function test failed.	<ol style="list-style-type: none"> <li>1. Check the ADI module is correctly inserted</li> <li>2. Check the ADI module is not damaged and working properly</li> </ol>
Il display visualizza <b>Er13</b>	Il circuito di autodiagnosi ha rilevato un malfunzionamento che impedisce il funzionamento sicuro dell'automazione	Contattare il servizio di assistenza tecnica V2 per inviare la centrale in riparazione
Il display visualizza <b>Er14</b>	Il circuito di autodiagnosi ha rilevato un errore nella tabella dei parametri di configurazione	Entrare nel menù di configurazione, verificare attentamente tutti i parametri e correggere gli eventuali errori. Se l'errore persiste contattare il servizio di assistenza tecnica V2 per inviare la centrale in riparazione
Il display visualizza <b>Er15</b>	The duty cycle limit has been exceeded	The control unit will return to normal operation after a forced pause. In this situation it is still possible to activate the automation in EMERGENCY DEAD-MAN OPERATION mode (chapter 10)
Il display visualizza <b>Er20</b>	Incompatibility with hardware. The firmware cannot recognize the control panel	Contattare il servizio di assistenza tecnica V2 per inviare la centrale in riparazione

## 14 - TESTING AND START-UP

In implementing the automation device, these are the most important steps for guaranteeing maximum safety.

V2 recommends the application of the following technical standards:

- EN 12445 (Safety in the use of automated closures, test methods)
- EN 12453 (Safety in the use of automated closures, requirements)
- EN 60204-1 (Safety of Machinery, electrical equipment of machines, part 1: general principles)

In particular, with reference to the table in the section "PRELIMINARY CHECKS and IDENTIFICATION OF THE TYPE OF USE" in the majority of cases, it will be necessary to measure the impact force, in accordance with the provisions of EN 12445.

Adjusting the operating force is possible by programming the electronic circuit board, and the impact force profile should be measured using an appropriate device (itself also certified and subjected to annual calibration) capable of tracing the force-time graph.

The result should be in compliance with the following maximum values:

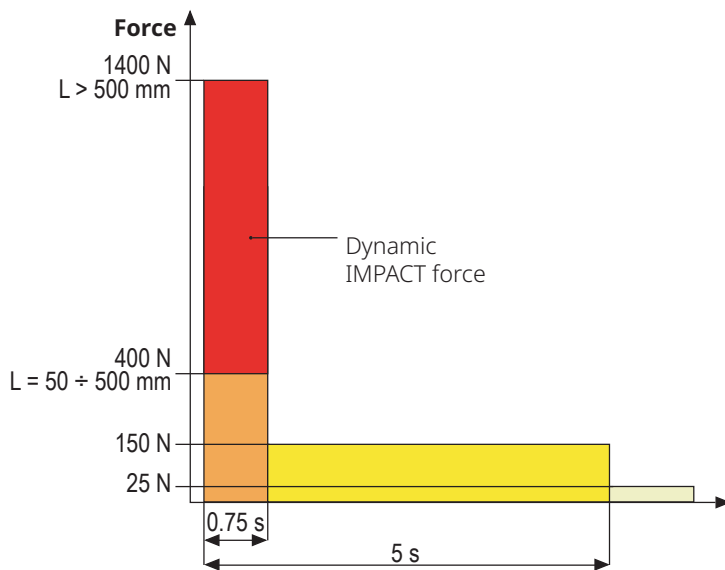

## 15 - MAINTENANCE

Maintenance should be performed in full compliance with the safety instructions described in this manual and in accordance with current legal and regulatory provisions.

The recommended interval between each maintenance operation is six months, the checks involved should at least relate to:

- the perfect efficiency of all warning devices
- the perfect efficiency of all safety devices
- measurement of the gate operating forces
- the lubrication of mechanical parts on the automation device (where necessary)
- the state of wear of the mechanical parts on the automation device
- the state of wear of the electrical cables on the electromechanical actuators

The result of each check should be recorded in a gate maintenance log.



## 16 - DISPOSAL OF THE PRODUCT

As for the installation operations, even at the end of this product's life span, the dismantling operations must be carried out by qualified experts.

This product is made up of various types of materials: some can be recycled while others need to be disposed of. Find out about the recycling or disposal systems envisaged by your local regulations for this product category.

**Important!** – Parts of the product could contain pollutants or hazardous substances which, if released into the environment, could cause harmful effects to the environment itself as well as to human health. As indicated by the symbol opposite, throwing away this product as domestic waste is strictly forbidden. So dispose of it as differentiated waste, in accordance with your local regulations, or return the product to the retailer when you purchase a new equivalent product.

**Important!** – the local applicable regulations may envisage heavy sanctions in the event of illegal disposal of this product.

# AUTOMATION DEVICE USERS MANUAL

## AUTOMATION DEVICE USER INFORMATION

An automation system is a great convenience, in addition to a valid security system, and with just a little, simple care, it is made to last for years.

Even if your automation device meets all the safety standards, this does not exclude the presence of residual risk, i.e. the possibility that hazardous situations may be created, usually due to irresponsible or even improper use, and for this reason we wish to offer some advice regarding the behaviour to be adopted in order to avoid problems:

**Prior to using the automation device for the first time**, ask the installer to explain the sources of residual risk to you, and take some time to read the instruction manual and user information delivered by the installer. Keep the manual for any future doubts and give it to any new owners of the device.

**Your automation device is a machine that faithfully follows your commands**; irresponsible and improper use can make it become hazardous: do not start movement of the device if there are people, animals or objects within its radius of action.

**Children**: installed in accordance with technical regulations, an automation system guarantees a high level of safety. However, it is prudent to prevent children from playing near the automation device and to avoid unintentional use; never leave the remote control within the reach of children: it is not a toy!

**Anomalies**: as soon as the automation device shows any anomalous behaviour, remove the electricity supply and perform manual unblocking. Do not attempt any repairs yourself, but ask your installer: in the meantime, the system can operate as a non-automated device.

**Maintenance**: as with all machinery, your automation devices requires periodic maintenance so that it may continue to work for as long as possible, and in complete safety. Agree a periodic maintenance plan with your installer; V2 SpA recommends a maintenance plan to be performed every 6 months for normal domestic use, but this period may vary depending on the intensity of use.

Any inspection, maintenance or repairs should only be performed by qualified personnel. Even if you think you know how, do not modify the system and the automation device programming and adjustment parameters: your installer is responsible for this. Final testing, periodic maintenance and any repairs should be documented by those performing the operations, and the documents held by the system owner.

**Disposal**: on completion of the device's operating life, ensure that disposal is performed by qualified personnel and that the materials are recycled or disposed of in accordance with valid local regulations.

**Important**: If your device is fitted with a radio control, the function of which appears to deteriorate over time, or has even ceased to function, this might simply depend on the batteries being run down (depending on the type, this may be from several months to up to two/three years). Before contacting your installer, try replacing the battery with the battery from another, working transmitter: if this was the cause of the problem, then simply replace the battery with another of the same type.

**Are you satisfied?** Should you wish to add another automation device to your home, contact the same installer and ask for a V2 SpA product: we guarantee you the most advanced products on the market and maximum compatibility with existing automation devices.

Thank you for having read these recommendations, and for any present or future needs, we ask you to contact your installer in full confidence.

## MOTOR OVERRIDING SYSTEM

The gearmotor is equipped with a mechanical unlocking system that allows for opening and closing the gate manually.

These manual operations should only be performed in case of a power outage, malfunctions or during the installation phases.

To unlock the device:

1. Open the locking hook using the key provided
2. At this point, the automation can be moved manually to the desired position.
3. To lock the gate, close the locking hook, turn the key anti-clockwise and remove it.

