

## HYPER

Ambidextrous irreversible operator for swing door gates.



## INDEX

1. GENERAL SAFETY WARNINGS	3
2. DESCRIPTION	3
3. LIST OF PACKAGING, ACCESSORIES AND OVERALL DIMENSIONS	4
4. PRODUCT VIEW AND TECHNICAL CHARACTERISTICS	6
5. PRELIMINARY CHECKS	8
6. INSTALLATION	11
7. MAINTENANCE	15
8. PRODUCT DISPOSAL	15
9. WARRANTY	15



[remotecontrolgates.co.uk](http://remotecontrolgates.co.uk)

## 1. GENERAL SAFETY WARNINGS



### WARNING!

Before installing the product it is mandatory to read the document related to the **GENERAL SAFETY WARNINGS** accompanying the product. Document **6-1620001**. The additional sheet can also be downloaded from [www.allmatic.com](http://www.allmatic.com).

## 2. DESCRIPTION

Amibidextrous irreversible gearmotor for swing gates with doors up to 4.5 m long and up to 300kg.

The irreversibility of this gearmotor means that the gate does not require any type of electric lock for effective closure. The motor is provided with thermal protection that in case of prolonged use momentarily interrupts the movement.

The HYPER motor provides great flexibility of installation as you can install it with the motor body facing down or up. It is also equipped with internal mechanical stoppers (optional) totally hidden from view and adjustable through the appropriate external screws that guarantee an elegant design.

## TYPICAL INSTALLATION

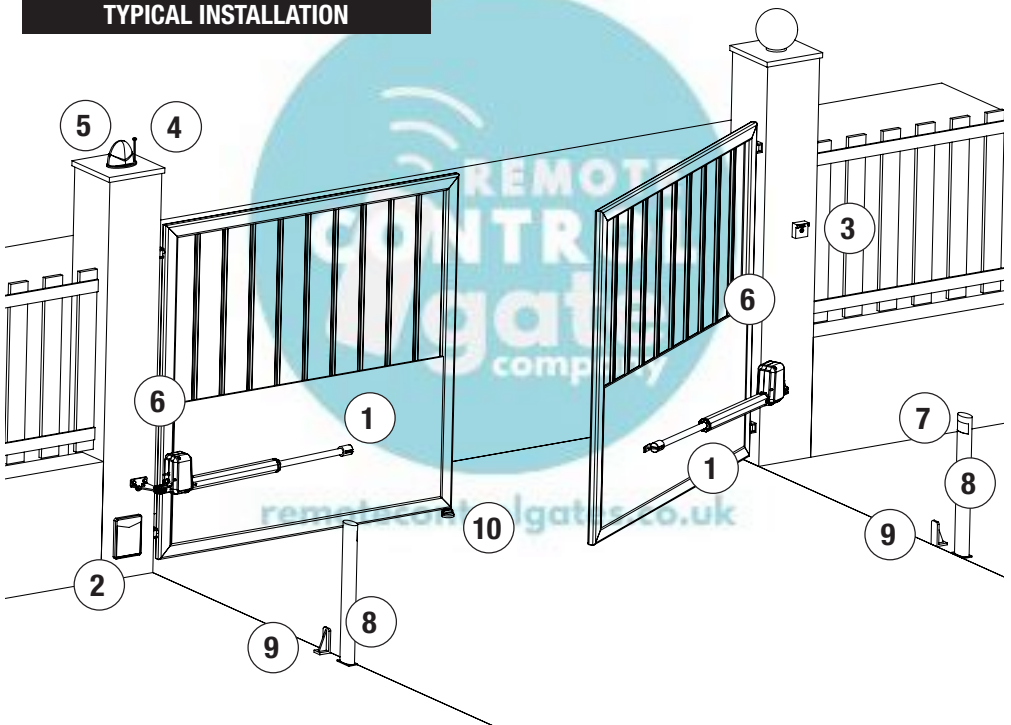

### Description:

- |    |                |     |                                      |
|----|----------------|-----|--------------------------------------|
| 1. | HYPER          | 6.  | Photocell of external protection     |
| 2. | Control unit   | 7.  | Photocell of internal protection     |
| 3. | Key selector   | 8.  | Photocell column                     |
| 4. | Radio antenna  | 9.  | Fixed mechanical stopper for opening |
| 5. | Flashing light | 10. | Fixed mechanical stopper for closing |

### 3. LIST OF PACKAGING, ACCESSORIES AND OVERALL DIMENSIONS

#### HYPER

Gearmotor for gates with hinged doors complete with assembly kit consisting of: fixing brackets, capacitor, unlocking key and hardware fasteners.



GEARMOTOR



PIVOTS AND SEEGER



KEY



REAR BRACKET



FRONT BRACKET



CAPACITOR

TABLE 1 - HYPER model codes

version	400			600		
Number of internal mechanical stoppers	0	1	2	0	1	2
230Vac 50Hz	12008100	12008101	12008102	12008130	12008131	12008132
120Vac 60Hz	12008110	12008111	12008112	12008140	12008141	12008142
24Vdc	12008120	12008121	12008122	12008150	12008151	12008152

#### ACCESSORIES



##### OPTIONAL INTERNAL MECHANICAL STOPPERS

Mechanical stoppers internally mounted and adjustable by screw.

Motor available in version with single mechanical stopper (only opening) or double mechanical stoppers (opening and closing).

### REAR BRACKET FOR FIXING

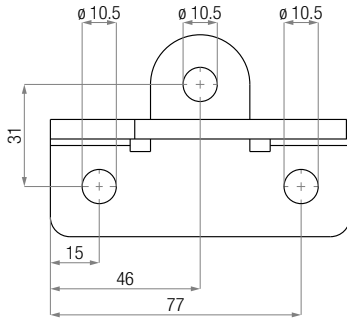

### FRONT BRACKET FOR FIXING

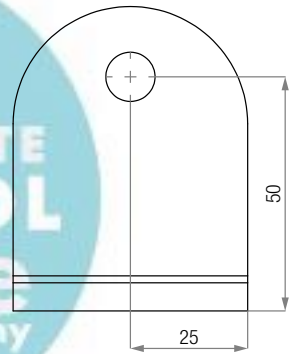
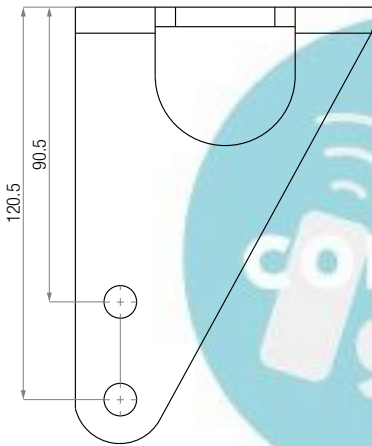
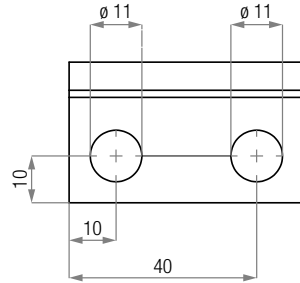

### WITHOUT INTERNAL MECHANICAL STOPPERS

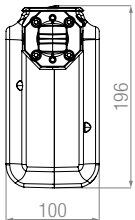

790 (HYPER 400)  
990 (HYPER 600)

### WITH INTERNAL MECHANICAL STOPPERS (1 or 2)

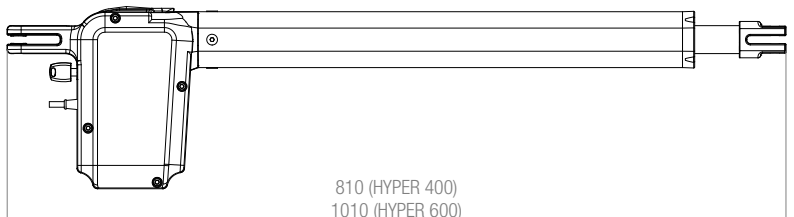

810 (HYPER 400)  
1010 (HYPER 600)

## 4. PRODUCT VIEW AND TECHNICAL CHARACTERISTICS

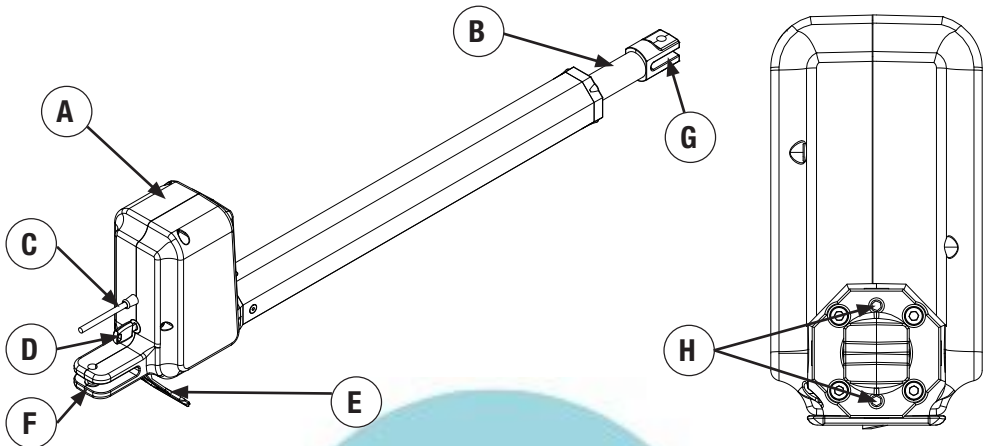

Description:

- |                            |   |
|----------------------------|---|
| A. Motor body              | F. Fixing point for rear bracket                                |
| B. Motor stem              | G. Fixing point for front bracket                               |
| C. Motor supply cable      | H. Screws for adjusting internal mechanical stoppers (optional) |
| D. Key to unlock           |   |
| E. Release lever to unlock |   |

TABLE 2 - HYPER 400 technical characteristics

TECHNICAL CHARACTERISTICS	U.M.	HYPER 400		
Recommended control board		BIOS2 24	BIOS2 120 / ECO	BIOS2 230 / ECO
Supply voltage and frequency		24 Vdc	120Vac 60Hz	230Vac 50Hz
Motor absorption	A	3	1	1
Motor power	W	70	120	230
Capacitor	µF	--	31,5	8
Motor speed	rpm	1700	1750	1450
Average opening time (90°)	sec.	17	17	20
Maximum gate size (Weight/Length)		100 kg / 3 m 133 kg / 2,5 m 200 kg / 1,5 m	150 kg / 3 m 183 kg / 2,5 m 250 kg / 1,5 m	200 kg / 3 m 233 kg / 2,5 m 300 kg / 1,5 m
Maximum thrust	N	1600	2000	2000
Service	%	70	50	50
Recommended daily cycles	n°	100	100	100
Weight of the motor	kg	6	7	7
Operating temperature	°C	-20°C ... +55°C		
Degree of protection	IP	44		
Emergency release		lever release with key		
Internal mechanical stoppers		optional		

TABLE 3 - HYPER 600 technical characteristics

TECHNICAL CHARACTERISTICS	U.M.	HYPER 600		
Recommended control board		BIOS2 24	BIOS2 120 / ECO	BIOS2 230 / ECO
Supply voltage and frequency		24 Vdc	120Vac 60Hz	230Vac 50Hz
Motor absorption	A	3	1	1
Motor power	W	70	120	230
Capacitor	µF	--	31,5	8
Motor speed	rpm	1700	1750	1450
Average opening time (90°)	sec.	25	25	30
Maximum gate size (Weight/Length)		100 kg / 4,5 m 140 kg / 3,5 m 200 kg / 2 m	150 kg / 4,5 m 190 kg / 3,5 m 250 kg / 2 m	200 kg / 4,5 m 240 kg / 3,5 m 300 kg / 2 m
Maximum thrust	N	1600	2000	2000
Service	%	70	50	50
Recommended daily cycles	n°	100	100	100
Weight of the motor	kg	7	8	8
Operating temperature	°C	-20°C ... +55°C		
Degree of protection	IP	44		
Emergency release		lever release with key		
Internal mechanical stoppers		optional		

TABLE 4 - Stem stroke

AVAILABLE STEM STROKE	U.M.	HYPER 400	HYPER 600
Without mechanical stoppers	mm	415	615
With 1 mechanical stopper (opening)	mm	395	595
With 2 mechanical stoppers (opening and closing)	mm	375	575

**ATTENTION! ONLY FOR 24V MOTORS**

IN NO CASE SHALL THE MAXIMUM WEIGHTS AND DIMENSIONS GIVEN IN THESE TABLES BE EXCEEDED.

ALWAYS USE THE SLOWDOWNS SET BY THE CONTROL UNIT FOR THE MOVEMENT OF THE GATE.



**WARNING!**

In the graph next to it is reported, as an explanatory example, the relationship between weight and length of the door for the gearmotor HYPER 400 230vac.

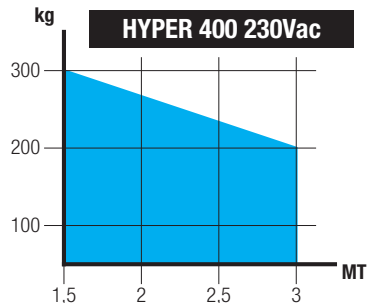

## 5. PRELIMINARY CHECKS

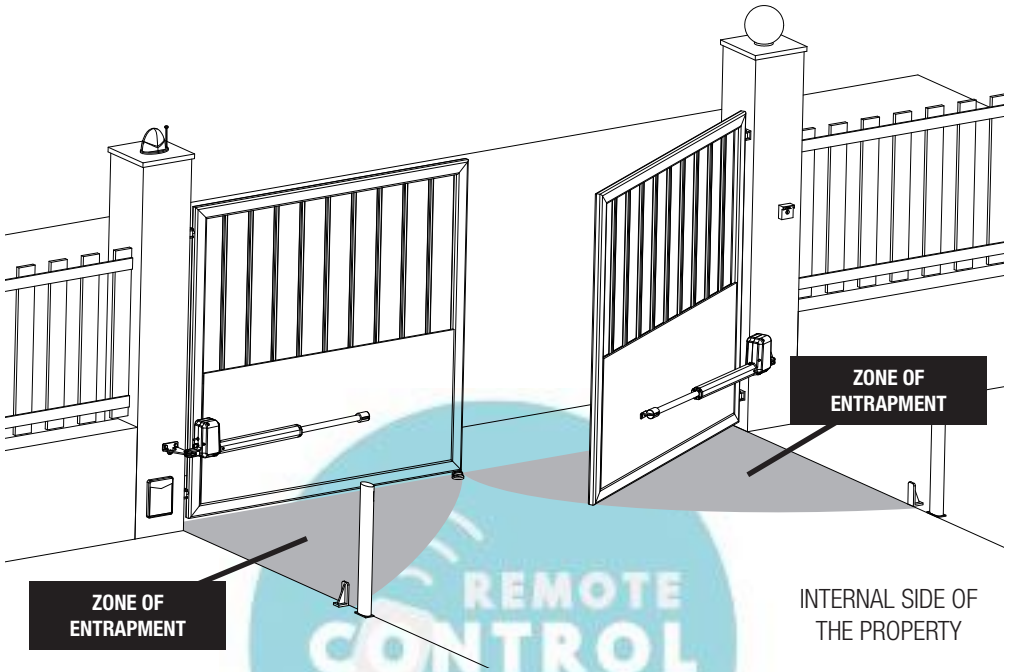

**WARNING!** It is mandatory to conform the characteristics of the gate to the rules and laws in force. The door can be automated only if it is in good condition and complies with EN 12604.

- The door shall not have pedestrian doors. Otherwise, precautions must be taken in accordance with point 5.4.1 of EN12453 (for example, to prevent the movement of the motor when the door is open, thanks to a micro-switch properly connected in the control unit).

- There is no need to generate entrapment points (for example, between the open door of the gate and the gate).

- There must be no mechanical stops above the gate because they are not sufficiently safe.

**WARNING!** The doors shall be firmly attached to the hinges of the columns, shall not flex during movement and shall move without friction. Before installing the motor it is better to check all the space necessary to be able to install it.

TABLE 5 - Components to be installed according to EN12453

CONTROL TYPE	USE OF CLOSURE		
	Experienced people (outside public area*)	Experienced people (public area)	Unlimited use
dead man mode	A	B	not possible
with visible impulses (e.g. sensor)	E	E	E
with not visible impulses (e.g. remote control)	E	E	E
automatic	E	E	E
* typical example are the closures that do not access public street A: Dead man mode (ie maintained action) control button. B: Key selector with manned operation. E: Photocells.			



## 5.1 CHECKS ON THE GATE

Before proceeding to the installation of the motor it is recommended to check the following on the gate:

- The gate must be level
- The gate must be in good condition
- The gate must not have protuberances that collide with the ground or other objects
- The gate must not hit or crawl the ground at any point of the race
- The gate must be easily opened and closed for the full width of its run and must be supported only by its hinges
- The gate must meet the weight and size requirements indicated in this manual

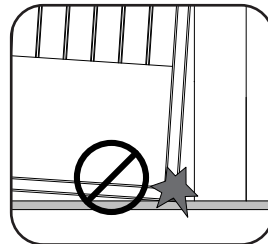
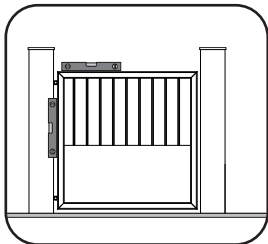

## 5.2 PREPARATION OF THE INSTALLATION SITE

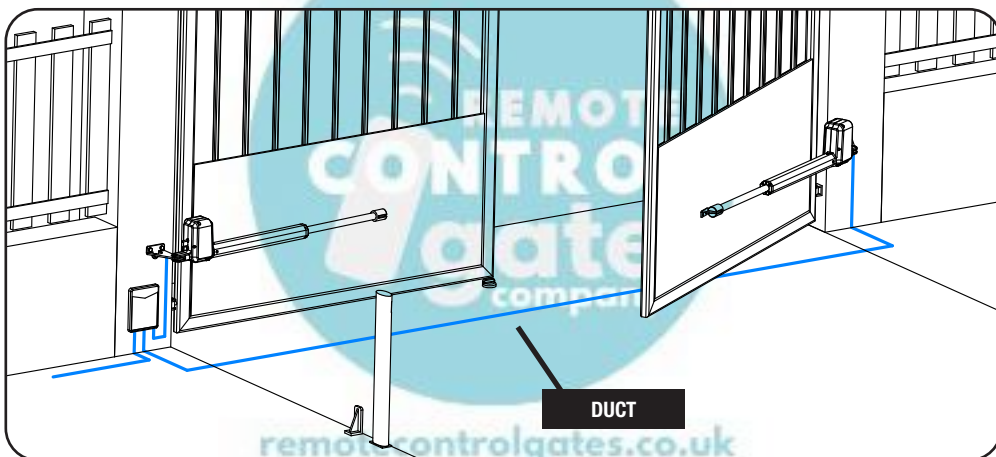

Prepare on the installation site the ducts for the passage of motor cables.

The cables for the connection of the various devices in a typical plant are listed in the table below and must be suitable for the type of installation, for example we recommend a cable type H07RN-F for outdoor installation.

TABLE 6 - Cables to be used

CONNECTION	CABLE	MAXIMUM LENGTH
Power supply line	3 x 1,5mm <sup>2</sup>	20 m *
Motor	4 x 1,5mm <sup>2</sup>	10 m *
Flashing light	2 x 0,5mm <sup>2</sup>	20 m
Photocell - transmitter	2 x 0,5mm <sup>2</sup>	20 m
Photocell - receiver	4 x 0,5mm <sup>2</sup>	20 m
Key selector	4 x 0,5mm <sup>2</sup>	20 m

\* If the cable exceeds 10 m, a cable with a larger section must be used and a safety grounding must be installed near the automation.

### 5.3 ADVICE ON INSTALLATION

#### WHAT YOU CAN DO:

- **Ensure that the motor is installed on level.**
- The motor shall be installed **at least 50 mm from the lower edge of the gate door.**
- The motor can be installed at the top of the gate door.
- The motor can be installed on both left and right.
- The motor can be installed with the body facing downwards or upwards depending on your needs.

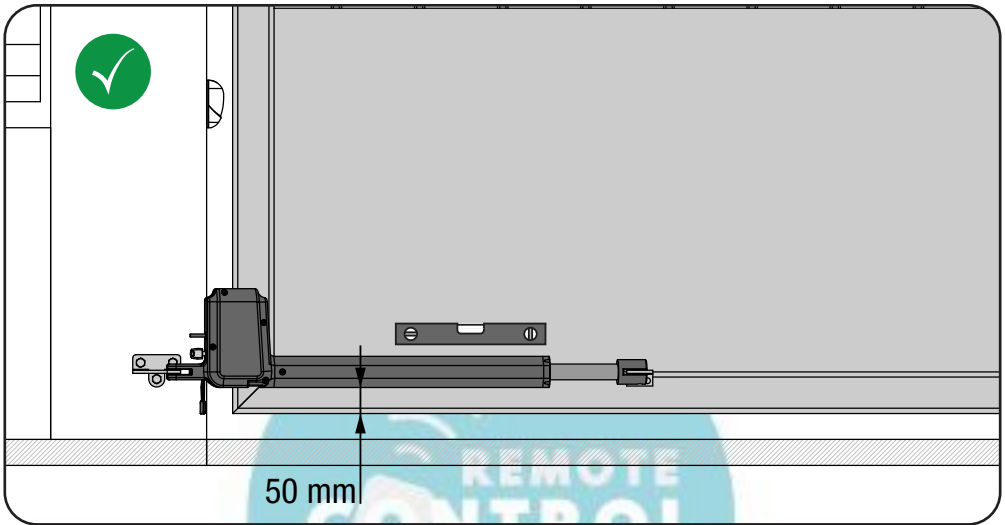

#### WHAT **NOT** TO DO:

- Do not install on sloping gates.
- Do not unduly bend the motor cable.
- Do not install the bracket in the gate in weak points that may break.



### 5.4 MOTOR UNLOCK FOR MANUAL MOVEMENT

To move the gate manually proceed as follows:

- Turn the key clockwise to unlock the lever.
- Pull the lever all the way down.

Once the gate is positioned to re-lock the motor:

- Completely put the lever back inside its seat in the motor body.
- Hold the lever in place with one hand.
- Close the lever lock by turning the key counterclockwise.

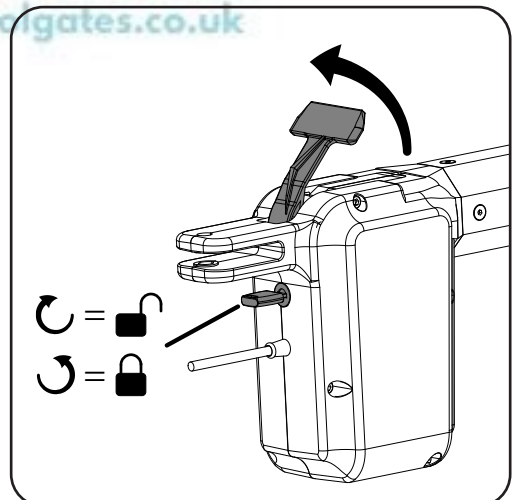

## 6. INSTALLATION

### 6.1 DETERMINE THE INSTALLATION MEASUREMENTS (OPENING INWARDS)

Before fixing the supplied brackets it is necessary to determine the installation dimensions A and B.

**Start by putting the gate in position of "CLOSED DOOR".**

Choose the sizes of A and B according to your installation and in order to obtain the desired degree of opening "α". This grade shown in the table refers to **the highest possible degree of openness** with the corresponding dimensions.

To anchor the piston use the brackets provided.

#### WARNING!

The values given in the following tables are indicative and have been calculated considering the ideal conditions with a gate of medium size, with a uniformly distributed filling and with both the internal mechanical stoppers installed. Keep in mind that values may vary slightly and must be checked in advance.



TABLE 7 - HYPER 400 Recommended installation dimensions

B	A	155	160	165	170	175	180
	W (α)						
150		980 (110°)	982 (110°)	984 (110°)	985 (110°)	973 (104°)	968 (102°)
160		987 (108°)	992 (110°)	983 (105°)	978 (102°)	973 (100°)	968 (98°)
180		991 (100°)	986 (98°)	981 (96°)	976 (94°)	971 (93°)	966 (91°)
200		989 (92°)	984 (90°)	982 (90°)	981 (90°)	976 (88°)	964 (85°)

TABLE 8 - HYPER 600 Recommended installation dimensions

B	A	220	230	240	250	260	270
	W (α)						
220		1269 (110°)	1270 (110°)	1273 (110°)	1278 (110°)	1279 (110°)	1269 (107°)
240		1288 (110°)	1290 (110°)	1292 (110°)	1287 (107°)	1277 (104°)	1267 (101°)
260		1302 (108°)	1310 (110°)	1295 (104°)	1285 (101°)	1275 (99°)	1265 (97°)
280		1313 (105°)	1303 (101°)	1293 (98°)	1283 (96°)	1273 (94°)	1263 (92°)

remotecontrolgates.co.uk

TOP VIEW

EXTERNAL SIDE  
OF THE PROPERTY

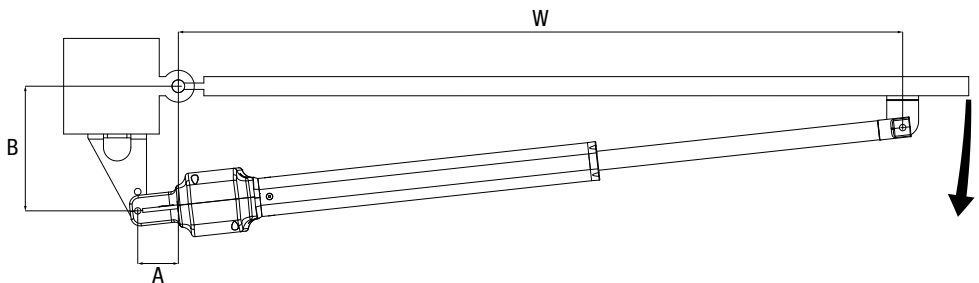

INTERNAL SIDE OF  
THE PROPERTY



## LEFT SIDE

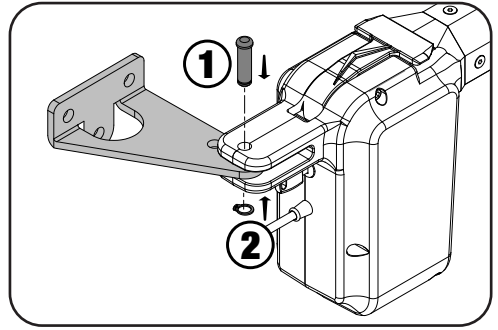
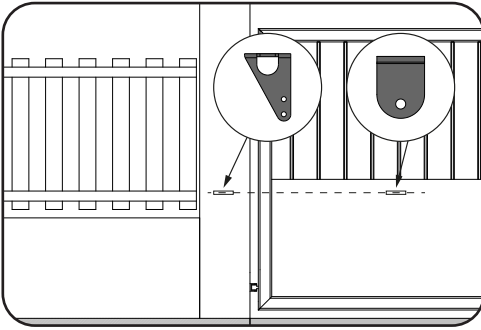

## RIGHT SIDE

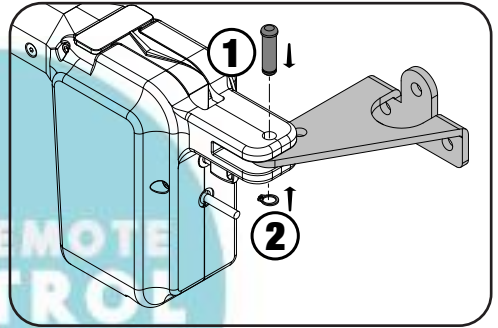
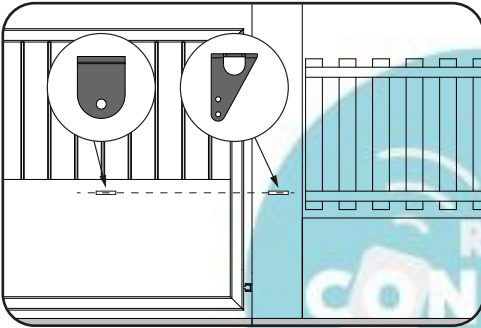

### 6.4 FASTEN THE FRONT BRACKET TO THE GATE

To install the front bracket follow these steps:

1. Unlock the motor.
2. Bring the door of the gate to the position of "CLOSED DOOR". **ATTENTION!** In case you are installing the motor with opening to the outside bring the door of the gate in the position of "OPEN DOOR".
3. Attach the front bracket to the motor actuator using the supplied hardware.
4. Stretch the stem completely and bring it back about 1 cm of its run.
5. With the stem in this position, pull the actuator with the bracket already installed to the gate and temporarily fix the bracket to the gate.
6. Verify that the motor is on level.
7. Carry out some manual opening and closing movements in order to verify that the gate moves smoothly and effortlessly and that the gear motor does not rub against the gate door.
8. Properly attach the front bracket to the gate and lock the motor.

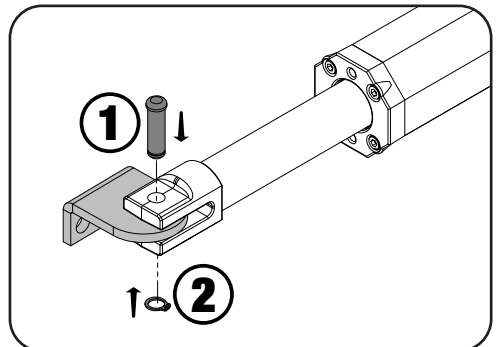
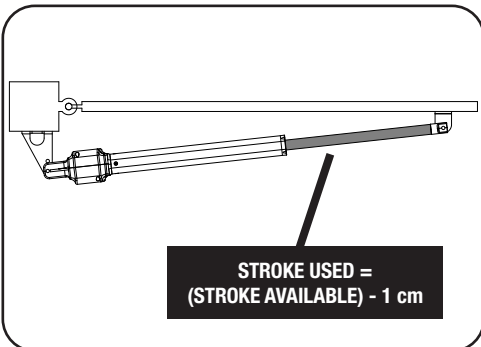

## 6.5 ADJUSTMENT OF INTERNAL MECHANICAL STOPPERS (OPTIONAL)

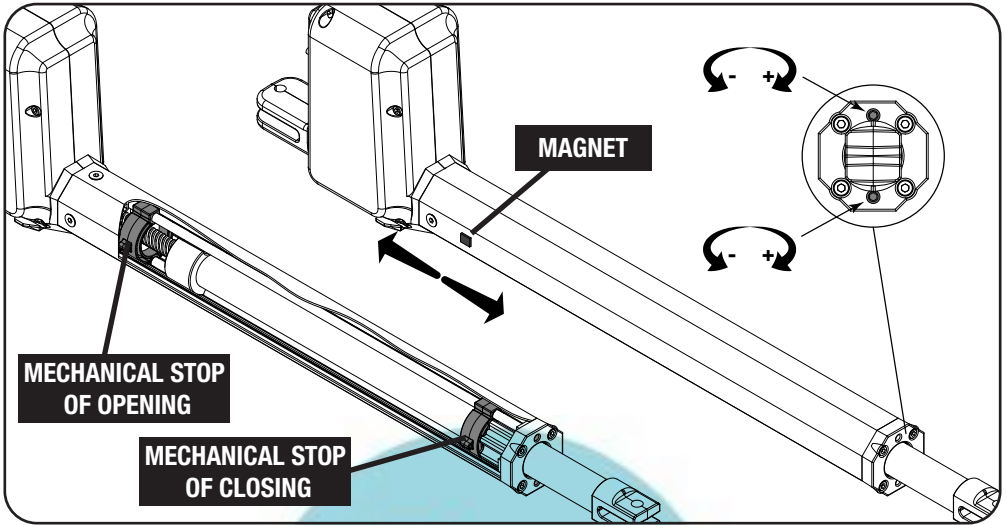

To adjust the internal mechanical stoppers (optional), proceed as follows:

1. Unlock the motor and manually open the gate to the position of "OPEN DOOR".
2. Approach a magnet (not supplied) or one of the washers provided in the kit on the motor body at the opening mechanical stopper until you find the point where it remains attached. In this way the magnet is located exactly at the mechanical stopper position and will be useful to understand which mechanical stopper you are acting by adjusting the screws and in which direction you are moving it.
3. Act on one of the two adjustment screws to find which of the two moves the magnet.
4. Adjust the correct screw founded so as to carry the magnet, and therefore the mechanical stopper, as far as possible from the gate hinge.
5. Repeat the operations described above also for the mechanical stopper of closing, bringing the gate first in the position of "CLOSED DOOR" and then acting on the other adjustment screw so that the magnet positioned on the closing mechanical stopper is as close as possible to the gate hinge.
6. Lock the motor.

After the adjustment, before connecting the motor to the control unit, make sure that manually moving the gate does not go beyond the desired limit positions. If so, repeat the procedure described above.

[remotecontrolgates.co.uk](http://remotecontrolgates.co.uk)

### WARNING!

If the motor is installed in such a way that the opening of the gate takes place towards the outside, reverse the references of this procedure with respect to the nomenclature of the mechanical stoppers.

In detail, the mechanical stopper that is closest to the motor body will be the MECHANICAL STOP OF CLOSING, while the farther one will be the MECHANICAL STOP OF OPENING.

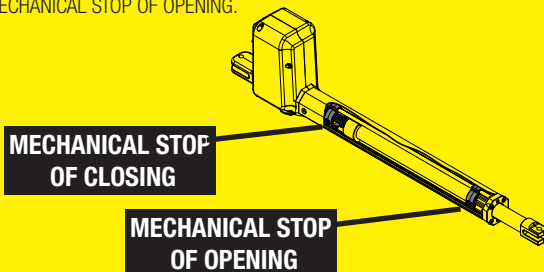

## 6.6 CONNECTION TO THE CONTROL UNIT

Make connections to the control unit only in the absence of power supply.

For the 230Vac and 120Vac gearmotors, install the capacitor supplied between Phase 1 and Phase 2 of the motor.

Please refer to the installation manual of the control unit for the connection diagram.

TABLE 9 - Cable colour for 230Vac motor

COLOUR	DESCRIPTION
Black	Phase 1
Brown	Phase 2
Grey or Blue	Neutral
Yellow / Green	Ground

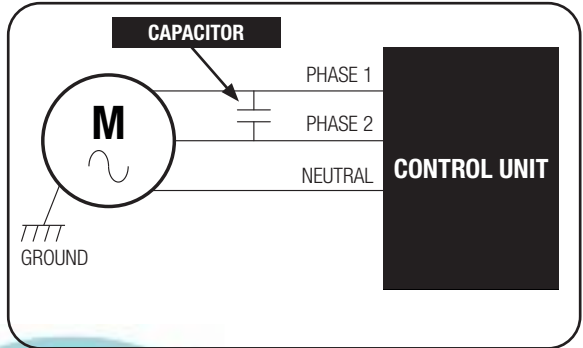

## 7. MAINTENANCE

For the correct maintenance of the automation, make sure to perform at least once every 6 months the following steps:

1. Check that all the fixing screws of the brackets are tight.
2. Check that the gate is in good condition and that there are no broken or worn parts.
3. Check the status of the electrical connections and in case of wear of the cables replace them.
4. Unlock the motor and move the gate manually by checking that the movement is fluid. In case it is necessary to put a layer of lubricating grease on the stem.

<input checked="" type="checkbox"/>	_____
<input checked="" type="checkbox"/>	_____
<input checked="" type="checkbox"/>	_____
<input checked="" type="checkbox"/>	_____

## 8. PRODUCT DISPOSAL

This product is an integral part of automation, and therefore must be disposed of together with it. As with installation operations, even at the end of the life of this product, dismantling operations must be carried out by qualified personnel. This product consists of various types of materials: some can be recycled, others must be disposed of. Find out about the recycling or disposal systems required by the regulations in force in your territory for this category of product.



**WARNING!** - certain parts of the product may contain pollutants or dangerous substances which, if dispersed in the environment, could have harmful effects on the environment and human health.

As indicated by the symbol on the side, it is forbidden to throw this product into household waste. Then perform the "separate collection" for disposal, according to the methods provided by the regulations in force in your territory, or return the product to the seller when buying a new equivalent product.

**WARNING!** - the regulations in force at local level may provide for heavy penalties in case of improper disposal of this product.

## 9. WARRANTY

The manufacturer's warranty is valid from the date stamped on the product and is limited to the repair or replacement free of charge of the parts recognized by the same as defective due to lack of essential quality in the materials or lack of processing. The warranty does not cover damage or defects due to external agents, maintenance deficiency, overload, natural wear, choice of incorrect type, assembly error, or other causes not attributable to the manufacturer. Tampered products will not be guaranteed or repaired. The data given are purely indicative. No liability may be charged for reductions in scope or malfunctions due to environmental interference. The liability of the manufacturer for damage caused to anyone by accidents of any nature caused by our defective products, are only those that derive from the Italian law.



[remotecontrolgates.co.uk](http://remotecontrolgates.co.uk)

**AM** **ALLMATIC**<sup>®</sup>

ALLMATIC S.r.l

32026 Borgo Valbelluna - Belluno – Italy

Via dell'Artigiano, n°1 – Z.A.

Tel. 0437 751175 – 751163 r.a. Fax 0437 751065

[www.allmatic.com](http://www.allmatic.com) - E-mail: [info@allmatic.com](mailto:info@allmatic.com)