

remotecontrolgates.co.uk

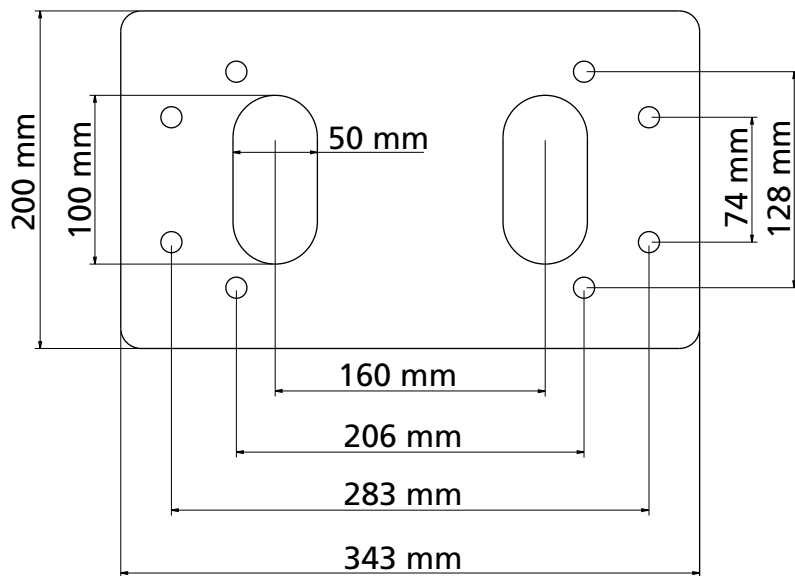

INDEX

1 - GENERAL SAFETY INFORMATION	28
1.1 - PRELIMINARY CHECKS AND IDENTIFICATION OF THE TYPE TO BE USED	29
1.2 - TECHNICAL ASSISTANCE SERVICE	30
1.3 - EU DECLARATION OF CONFORMITY	30
2 - TECHNICAL DATA	31
3 - INSTALLATION OF THE MOTOR	32
3.1 - INSTALLATION OF THE MOTOR	32
3.2 - MOUNTING THE RACK	33
3.3 - FIXING OF THE MOTOR	33
3.4 - INSTALLING THE MAGNETIC LIMIT SWITCHES	34
3.5 - MOTOR OVERRIDING SYSTEM	35
3.6 - INSTALLATION LAYOUT	35
4 - CONTROL UNIT	36
4.1 - POWER SUPPLY	36
4.2 - FLASHING LIGHT	36
4.3 - COURTESY LIGHTS	36
4.4 - ACTIVATION INPUTS	36
4.5 - STOP	37
4.6 - PHOTOCELLS	37
4.7 - SAFETY RIBBONS	37
4.8 - EXTERNAL AERIAL	37
4.9 - ELECTRICAL CONNECTION	38
4.10 - PLUG IN RECEIVER	39
4.11 - ADI INTERFACE	39
5 - CONTROL PANEL	40
5.1 - DISPLAY	40
5.2 - USE OF THE KEYS FOR PROGRAMMING	40
6 - ACCESSING THE CONTROL UNIT SETTINGS	41
7 - QUICK CONFIGURATION	41
8 - LOADING THE DEFAULT PARAMETERS	41
9 - SELF-LEARNING OF WORKING TIMES	42
10 - INVERTER BOARD FUNCTIONAL TEST	42
11 - EMERGENCY DEAD MAN OPERATION	43
12 - READING OF CYCLE COUNTER	43
12.1 - SIGNAL OF SERVICE REQUIRED	43
13 - PROGRAMMING THE CONTROL UNIT	44
14 - OPERATION DEFECTS	48
15 - TESTING AND START-UP	50
16 - MAINTENANCE	50
17 - DISPOSAL OF THE PRODUCT	50

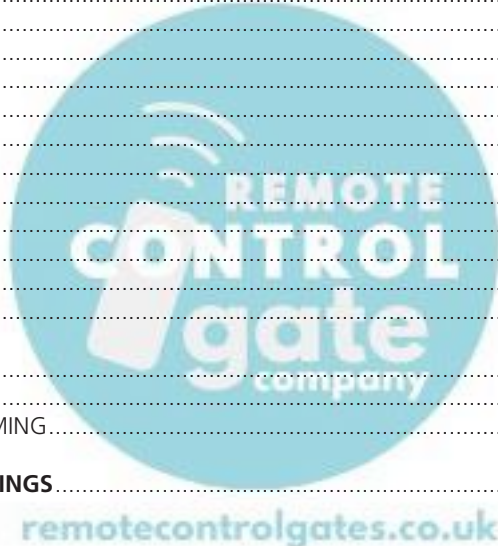

AUTOMATION DEVICE INSTALLERS MANUAL

1 - GENERAL SAFETY INFORMATION

 **Prior to proceeding with installation, it is essential the instructions be read in full, since they contain important information regarding safety, installation, use and maintenance.**

AUTOMATION MUST BE IMPLEMENTED IN COMPLIANCE WITH THE EUROPEAN REGULATIONS IN FORCE:

EN 60204-1, EN 12445, EN 12453, EN 13241-1, EN 12635

- The installer must provide for a device (es. magnetothermal switch) ensuring the omnipolar sectioning of the equipment from the power supply. The standards require a separation of the contacts of at least 3 mm in each pole (EN 60335-1).
- The plastic case has an IP44 insulation; to connect flexible or rigid pipes, use pipefittings having the same insulation level.
- Installation requires mechanical and electrical skills, therefore it shall be carried out by qualified personnel only, who can issue the Compliance Certificate concerning the whole installation (Machine Directive 2006/42/CEE, Annex IIA).
- Also the automation upstream electric system shall comply with the laws and rules in force and be carried out workmanlike.
- We recommend to make use of an emergency button, to be installed by the automation (connected to the control unit STOP input) so that the gate may be immediately stopped in case of danger.
- For correct installation of the system, we recommend following the instructions issued by UNAC very carefully
- This instruction manual is only for qualified technicians, who specialize in installations and automations.
- The contents of this instruction manual do not concern the end user.
- Every programming and/or every maintenance service should be done only by qualified technicians.
- Anything not expressly described in these instructions is prohibited; unforeseen uses may be a source of danger to people and property.
- Do not install the product in explosive environments and atmospheres: the presence of inflammable gases or fumes is a serious safety hazard.
- Do not make any modifications to any part of the automation device, or the accessories connected to it, unless described in this manual.
- Any other modifications will void the warranty on the product.
- The installation steps should be conducted so as to avoid rainy weather, which can expose electronic circuits to dangerous water seepage.
- All operations requiring the casing of the device to be opened should be performed with the control unit disconnected from the electricity supply and with a warning notice displayed, for example: "CAUTION, MAINTENANCE IN PROGRESS".
- Avoid exposing the device close to sources of heat and flame.

- In the event of interventions on automatic or differential breakers or fuses, it is essential that faults be identified and resolved prior to resetting. In the case of faults that cannot be resolved using the information to be found in this manual, consult the V2 customer assistance service.
- V2 declines all responsibility for failure to comply with good construction practice standards in addition to structural deformation of the gate that might occur during use.
- V2 reserves the right to make modifications to the product without prior warning.
- Installation/maintenance personnel should wear individual protection devices (IPDs), such as overalls, safety helmets, boots and gloves.
- The ambient operating temperature should be that indicated in the technical characteristics table.
- The automation device should be shut down immediately in the event of any anomalous or hazardous situation; the fault or malfunction should be immediately reported to the person responsible.
- All safety and hazard warnings on the machinery and equipment should be complied with.
- Electromechanical actuators for gates are not intended to be used by people (including children) with diminished physical, sensory or mental capacity, or lacking in experience or knowledge, unless they are under supervision or have been instructed in use of the actuator by a person responsible for safety.

V2 has the right to modify the product without previous notice; it also declines any responsibility to damage or injury to people or things caused by improper use or wrong installation.



1.1 - PRELIMINARY CHECKS AND IDENTIFICATION OF THE TYPE TO BE USED

The automation device should not be used until installation, as specified in "Testing and start-up", has been performed. It should be remembered that the device does not compensate for defects caused by improper installation, or poor maintenance, thus, prior to proceeding with installation, ensure that the structure is suitable and meets current standards and, if necessary, perform any structural modifications aimed at the implementation of safety gaps and the protection or segregation of all crushing, shearing and transit zones, and verify that:

- The gate has no friction points, either during closing or opening.
- The gate must be equipped with mechanical stoppers.
- The gate is well balanced, i.e. there is no tendency to move spontaneously when stopped in any position.
- The position identified for fixing the motor reducer allows easy and safe manual manoeuvring, compatible with the size of the motor reducer itself.
- The support on which the automation device will be fixed is solid and durable.
- The mains power supply to which the automation device is connected has a dedicated safety earthing system and differential breaker with tripping current less than or equal to 30 mA (the breaker gap distance should be greater than or equal to 3 mm).

Warning: The minimum safety level depends on the type of use; please refer to the following outline:

TYPE OF ACTIVATION COMMANDS	CLOSURE USE TYPE		
	GROUP 1 Informed people (use in private area)	GROUP 2 Informed people (use in public area)	GROUP 3 Informed people (unlimited use)
Man-present command	A	B	Not possible
Remote control and closure in view (e.g. infrared)	C or E	C or E	C and D or E
Remote control and closure not in view (e.g. radio)	C or E	C and D or E	C and D or E
Automatic control (e.g. timed closure control)	C and D or E	C and D or E	C and D or E

GROUP 1 - Only a limited number of people are authorised for use, and closure is not in a public area. Examples of this type are gates inside business premises, where the sole users are employees, or a part of them who have been suitably informed.

GROUP 2 - Only a limited number of people are authorised for use, but in this case, closure is in a public area. An example of this may be a company gate that accesses onto a public street, and which is only used by employees.

GROUP 3 - Anyone can use the automated closure, which is thus located on public land. For example the access gate to a supermarket or an office, or a hospital.

PROTECTION A - Closure is activated by means of a control button with the person present, i.e. with maintained action.

PROTECTION B - With the person present, closure is activated by a command controlled by means of a key-switch or the like, in order to prevent use by unauthorised persons.

PROTECTION C - Restricts the force of the leaf of the door or gate. I.e., in the case of the gate striking an obstacle, the impact force must fall within a curve established by the regulations.

PROTECTION D - Devices, such as photocells, capable of detecting the presence of people or obstacles. They may be active on just one side or on both sides of the door or gate.

PROTECTION E - Sensitive devices, such as footboards or immaterial barriers, capable of detecting the presence of a person, and installed in such a way that the latter cannot be struck in any way by a moving leaf or panel. These devices should be active within the entire "danger zone" of the gate. The Machinery Directive defines "Danger Zone" as any zone surrounding and/or near machinery where the presence of an exposed person constitutes a risk to the health and safety of that person.

The risk analysis should take into consideration all danger zones for the automation device, which should be appropriately protected and marked.

In a clearly visible area, apply a sign with information identifying the motorised door or gate.

The installer should provide the user with all the information relating to automatic operation, emergency opening and maintenance of the motorised door or gate.

1.2 - TECHNICAL ASSISTANCE SERVICE

For any installation problem please contact our Customer Service at the number +39-0172.812411 operating Monday to Friday from 8:30 to 12:30 and from 14:00 to 18:00.

1.3 - EU DECLARATION OF CONFORMITY AND DECLARATION OF INCORPORATION OF PARTLY COMPLETED MACHINE

Declaration in accordance with Directives: 2014/35/UE (LVD); 2014/30/UE (EMC); 2006/42/CE (MD) ANNEX II, PART B

The manufacturer V2 S.p.A., headquarters in Corso Principi di Piemonte 65, 12035, Racconigi (CN), Italy

Under its sole responsibility hereby declares that:
the partly completed machinery model(s):
AYROS1500-I

Description: electromechanical actuator for sliding gates

- is intended to be installed on sliding gates, to create a machine according to the provisions of the Directive 2006/42/EC. The machinery must not be put into service until the final machinery into which it has to be incorporated has been declared in conformity with the provisions of the Directive 2006/42/EC (annex II-A).
- is compliant with the applicable essential safety requirements of the following Directives:
Machinery Directive 2006/42/EC (annex I, chapter 1)
Low Voltage Directive 2014/35/EU
Electromagnetic Compatibility Directive 2014/30/EU
Directive ROHS2 2011/65/CE

The relevant technical documentation is available at the national authorities' request after justifiable request to:
V2 S.p.A.
Corso Principi di Piemonte 65, 12035, Racconigi (CN), Italy

The person empowered to draw up the declaration and to provide the technical documentation:

Antonio Livio Costamagna
Legal representative of V2 S.p.A.
Racconigi, il 01/06/2015



remotecontrolgates.co.uk

2 - TECHNICAL DATA

Gate maximum weight	1500 Kg
Power supply	230 VAC / 50 Hz
Maximum power	700 W
Full load current @ 230Vac	5 A
Gate maximum speed	0,35 m/s
Maximum thrust	1400 N
Duty cycle	50 %
Pinion	M4 - Z18
Operation temperature	-20 ÷ +55 °C
Weight	15 Kg
Protection	IP44
Maximum load on 24 VAC attachments	10 W
Protection fuses	10 A

WARNING: The following chart indicates the recommended maximum speed that can be programmed (via the μEL Parameter referenced on page 44) depending on door weight.



WARNING – DO NOT EXCEED THE INDICATED MAXIMUM SPEED

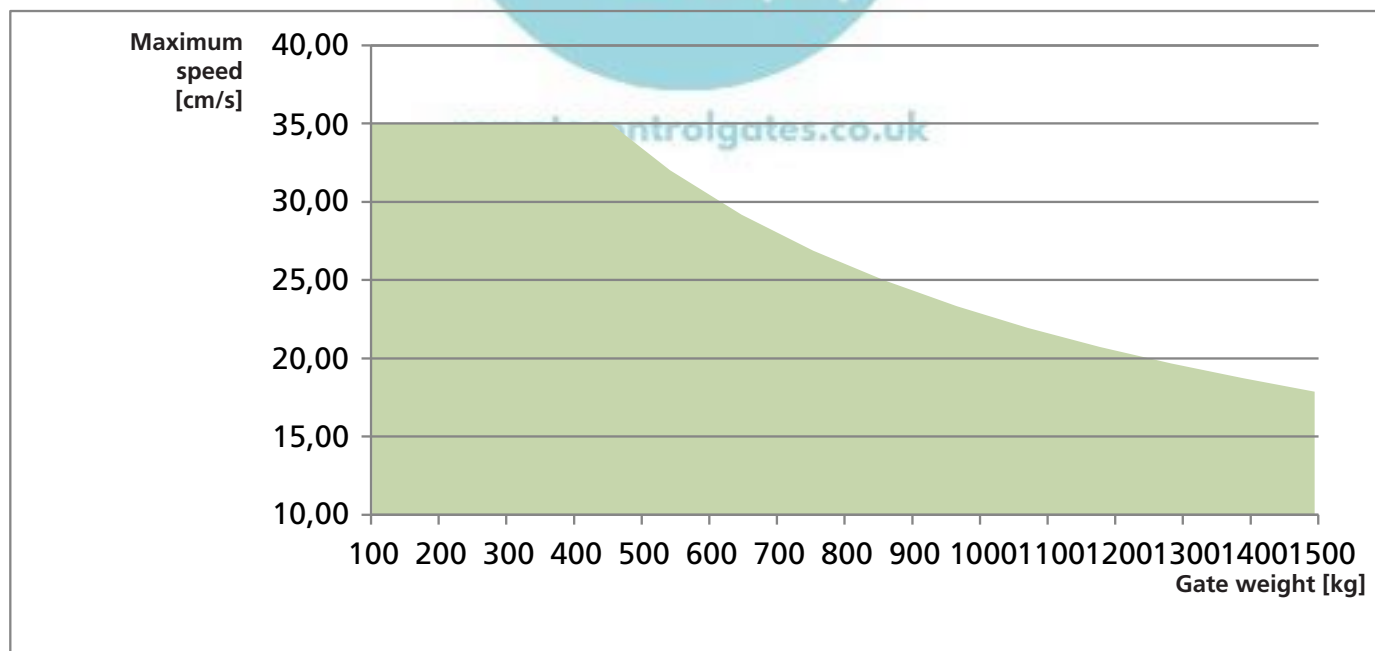
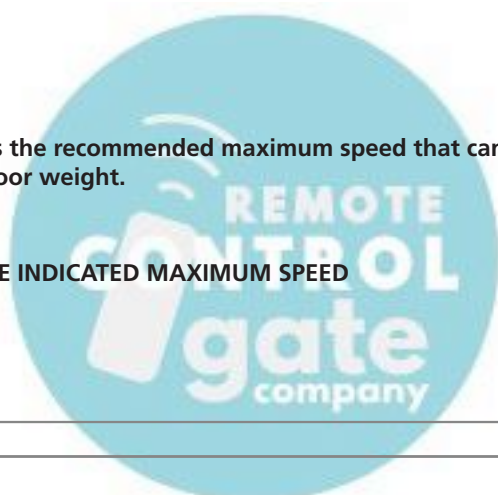

3 - INSTALLATION OF THE MOTOR

3.1 - POSITIONING OF THE MOTOR

To fix AYROS, follow the instructions below:

1. use the measurements indicated in the drawing for the foundations
2. Arrange for one or two pipes for the passage of electric cables
3. Assemble the 4 clamps on the anchoring plate and fix them with the 4 bolts issued with the motor
4. Pour the concrete and position the anchoring plate

⚠ WARNING: check that the plate be on a perfectly levelled surface and parallel to the gate

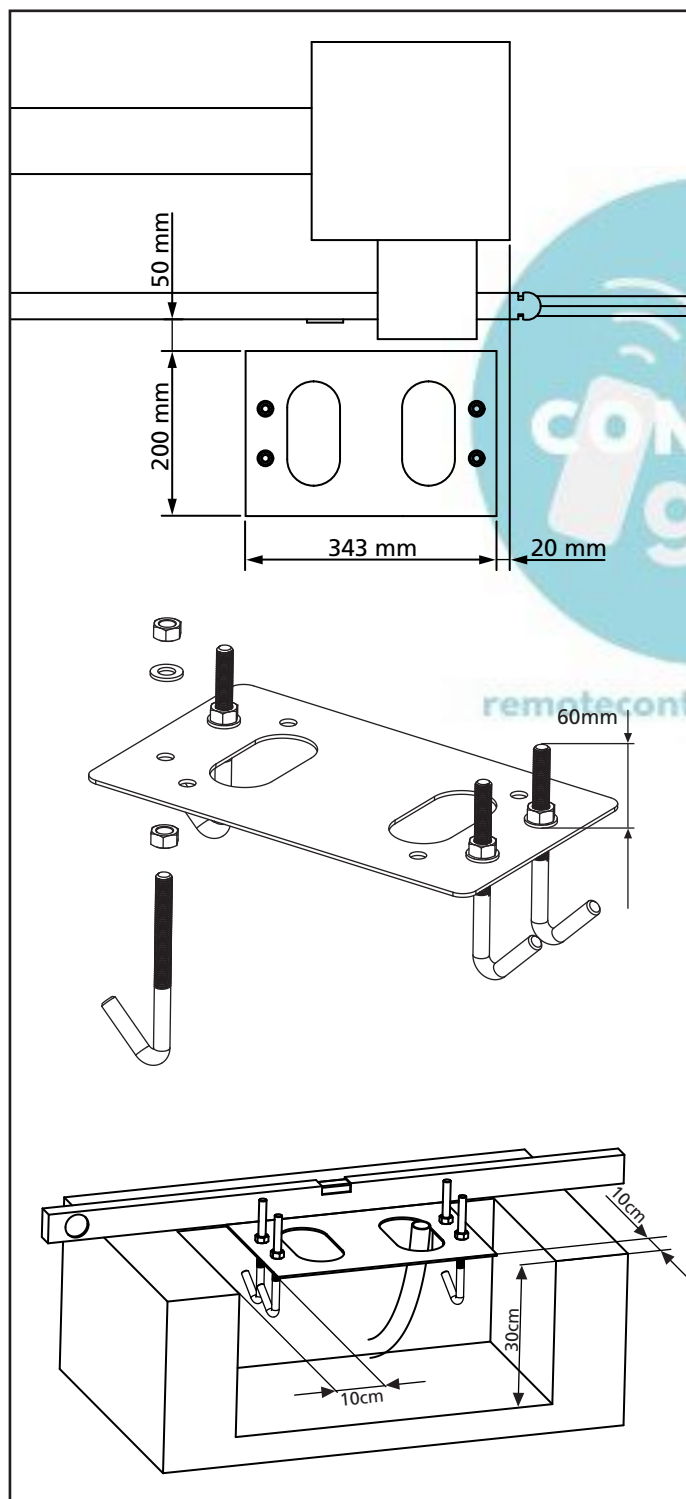

5. Wait for the complete setting of the concrete
6. Unscrew the bolts fixing the base to the clamps and put the motor on the plate
7. Adjust the 4 grains to make the motor be perfectly levelled
8. Control that the motor is perfectly parallel to the gate, then insert the 4 washers **R** and lightly screw the 4 bolts **D**

⚠ WARNING: put the washer **G** into the hole for the passing of the cables as shown in the picture. Pierce the washer to let the cable to be connected to the control unit pass, paying attention to the dimensions in order to avoid the entrance of insects and other small animals.

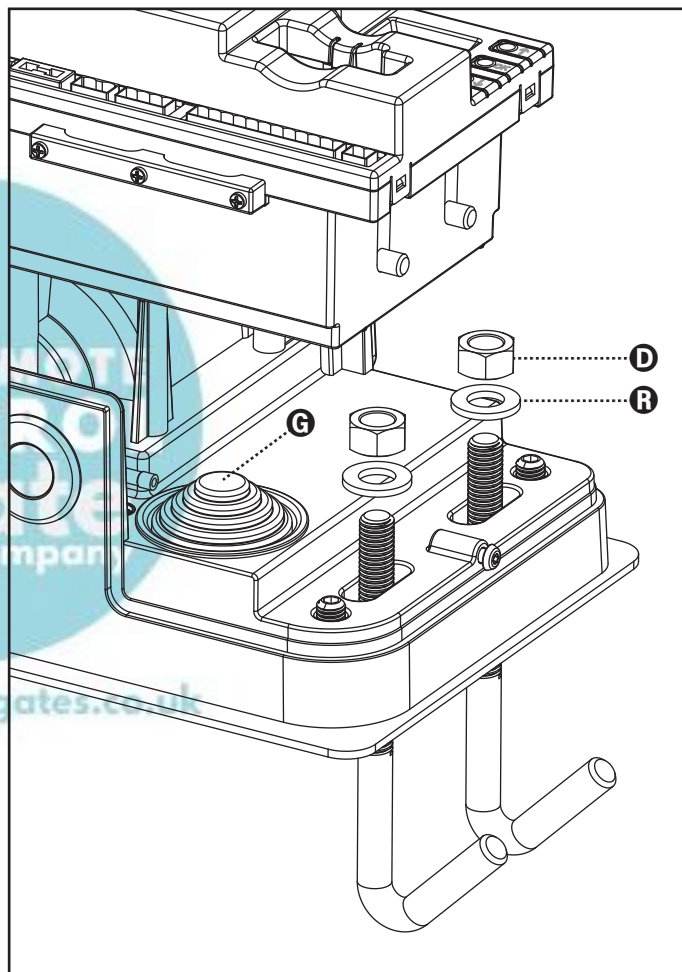

3.2 - MOUNTING THE RACK

1. Release the motor and turn the gate completely open.
2. Fix all the rack elements to the gate, making sure that they stand at the same height than the motor pinion.

The rack **MUST BE** positioned 1 or 2 mm over the pinion of the motor all the gate length.

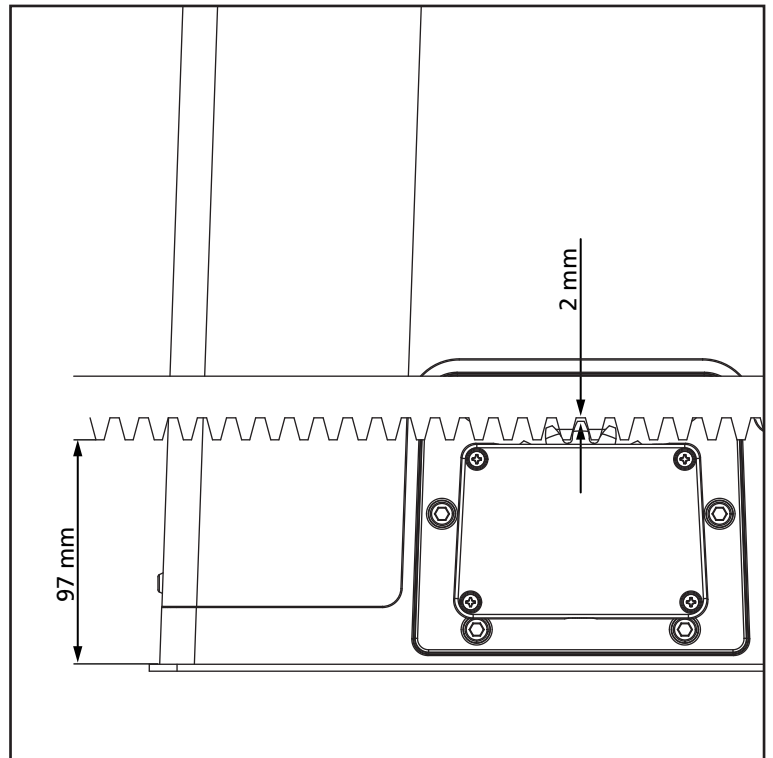

3.3 - FIXING OF THE MOTOR

Check the following points:

1. the motor must be on a levelled surface and perfectly parallel to the gate
2. the distance between pinion and rack must be 1 or 2 mm. If needed, adjust the 4 grains
3. the rack must be trued up with the pinion of the motor
4. the minimum distance between the maximum overall of the gate and the case of the pinion of the motor must be of at least 5 mm
5. Check the above indicated conditions and proceed fixing the 4 bolts **D** anchoring the motor to the plate.

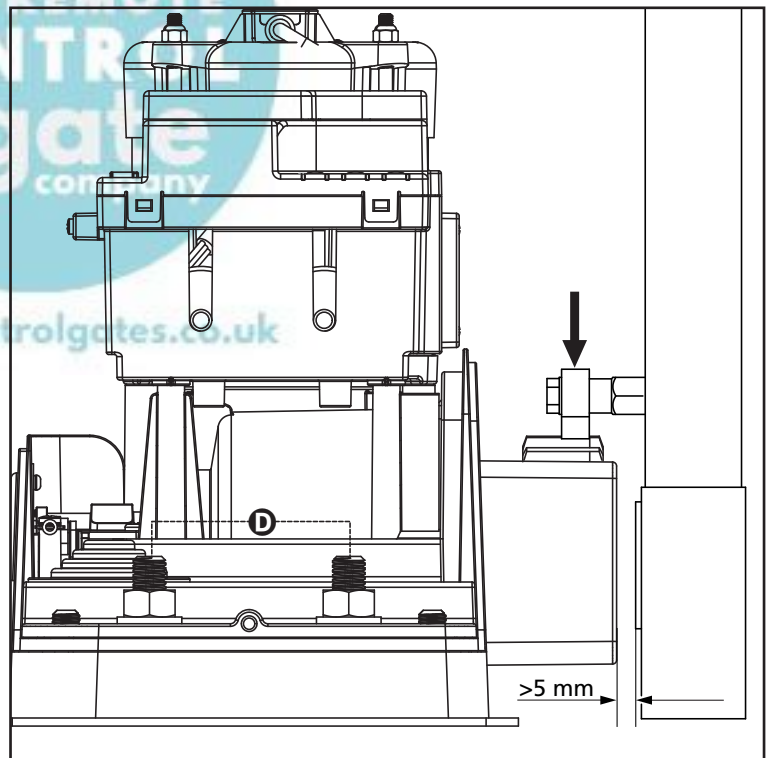

3.4 - INSTALLING THE MAGNETIC LIMIT SWITCHES

⚠ WARNING: For your safety, it is necessary that the gate is equipped with mechanical stoppers. If the gate is not equipped with these stoppers, an erratic movement past the range limit may cause the gate to fall.

Install the supplied magnet holder on the rack in a way that, in the opening and closing limit positions, the magnet be positioned next to the magnetic sensor behind the hood (as near as possible to the hood).

The supplied magnets have been colored differently in order to be distinguished from each other:

BLUE MAGNET = RIGHT LIMIT SWITCH (DX)
RED MAGNET = LEFT LIMIT SWITCH (SX)

The type of limit switch (RIGHT/LEFT) depends on the position of the limit switch towards the motor, independently from the opening sense.

⚠ WARNING: Once checked the proper working of the system, we suggest to weld the end-of-stroke brackets on the rack.

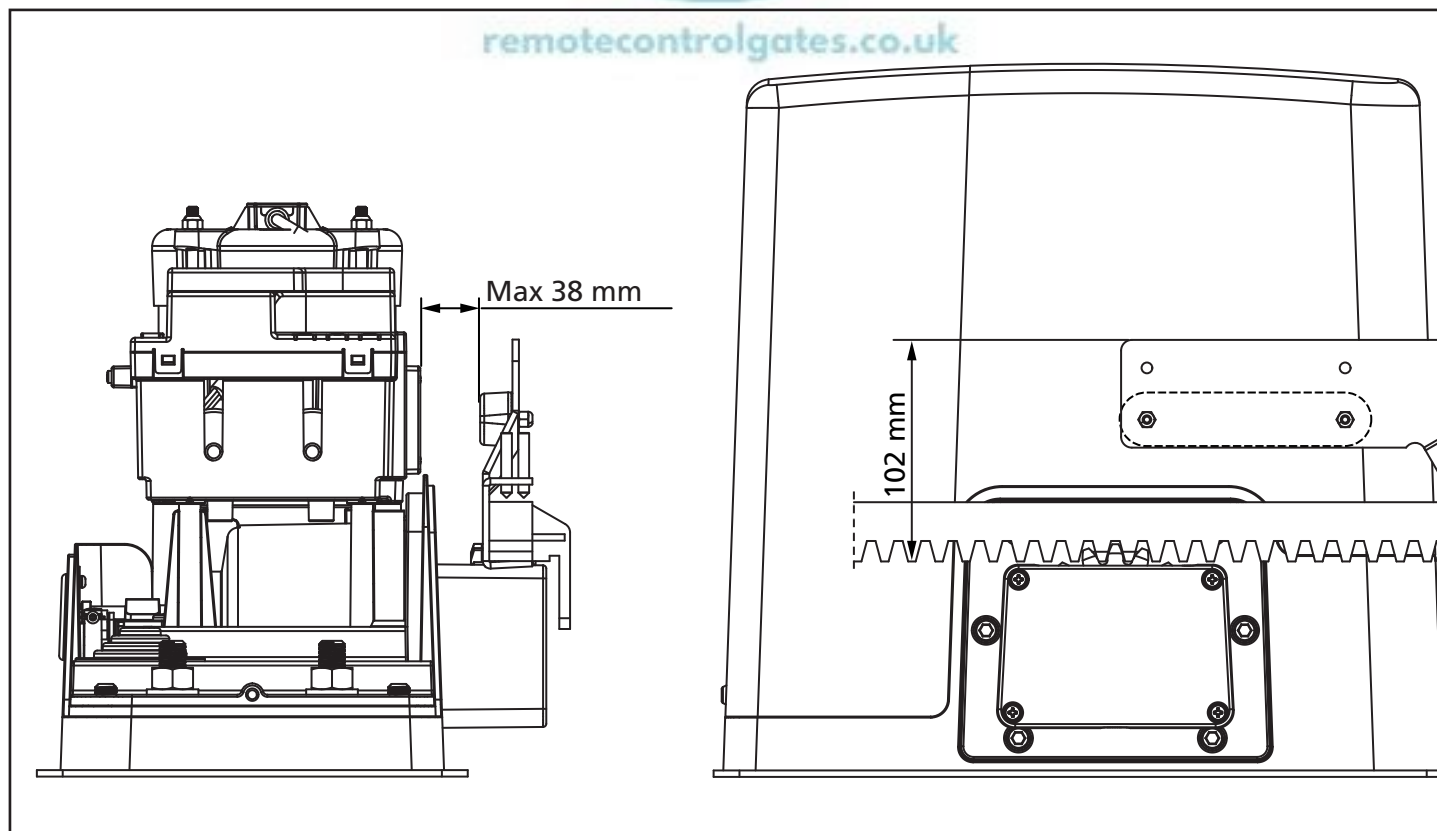
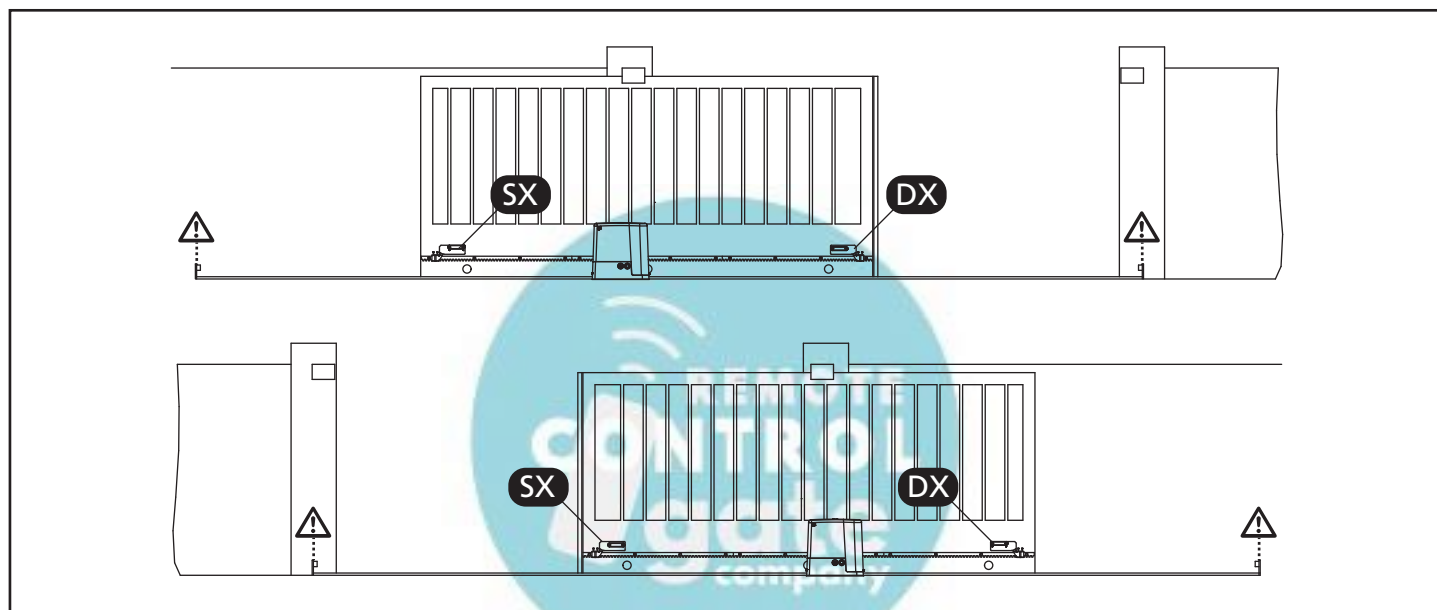

3.5 - MOTOR OVERRIDING SYSTEM

In case of absence of current, the gate can be released by operating on the motor:

1. Open the hatch of the lock **J** in front of the motor
2. Insert the key **K** in the lock and turn clockwise to open the hatch of the release on the side
3. Insert the key **L** into the hole and turn clockwise until reached the limit switch
4. At this point you can manually move the gate

To restore the automation, proceed as follows:

1. Bring the gate to the fully closed position
2. turn the key **L** anticlockwise until reached the limit switch, then draw it out
3. turn the key **K** anticlockwise closing the hatch of the lock, then draw it out
4. Close the lock with the hatch **J**

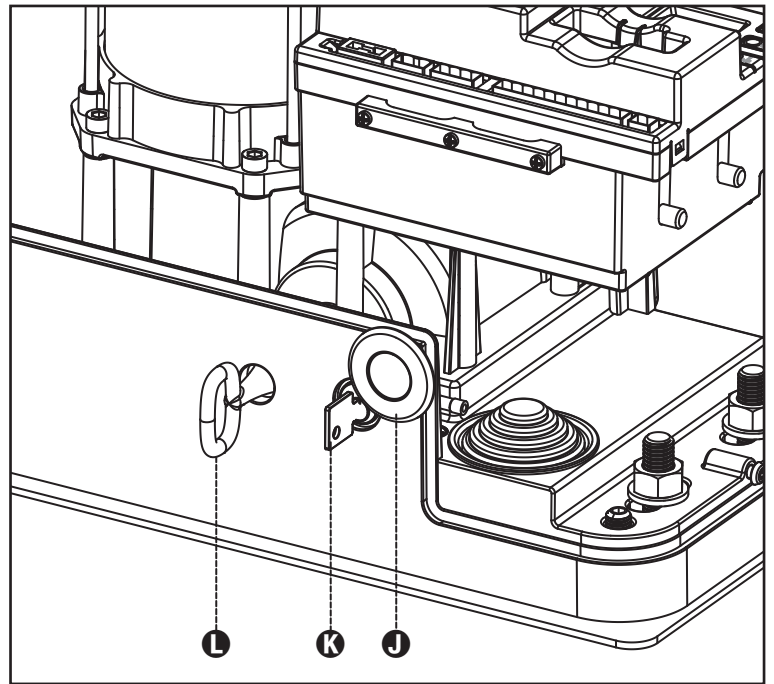

3.6 - INSTALLATION LAYOUT

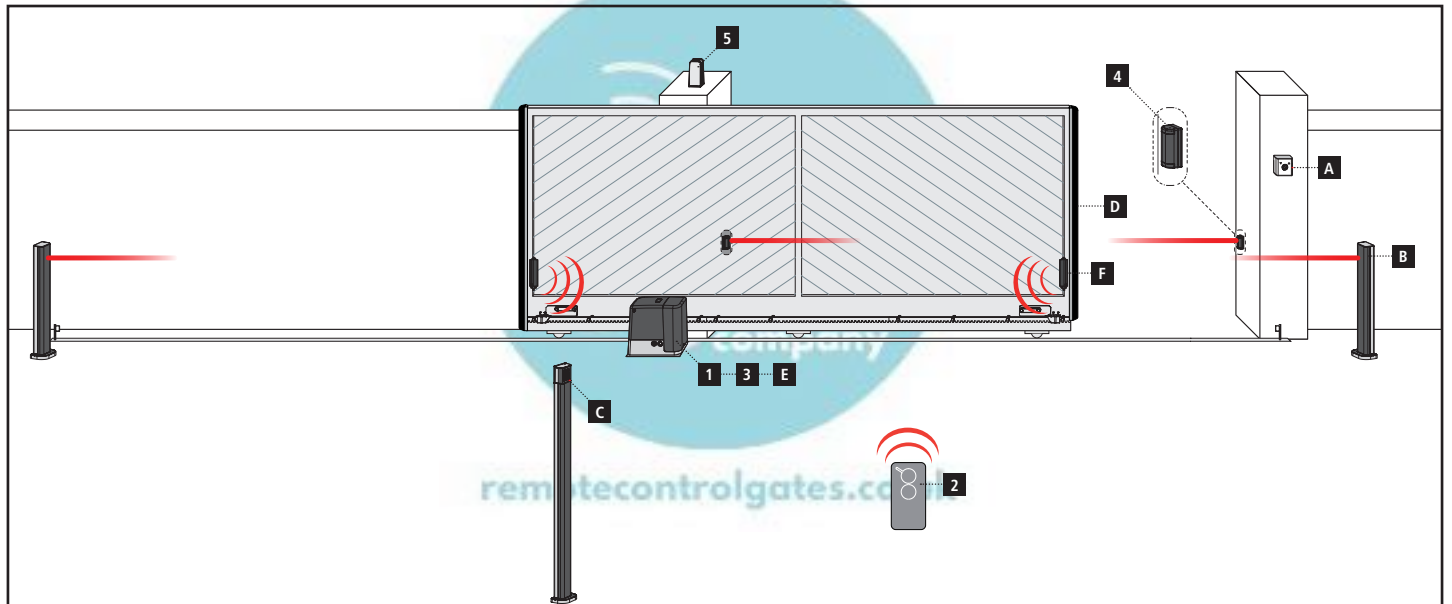

COMPONENTS

- 1** Motor
- 2** Transmitter
- 3** Receiving module
- 4** Photocells
- 5** Flashing light

ADDITIONAL ACCESSORIES

- A** Key switch
- B** Pillar photocells
- C** Pillar-mounted digital radio switch
- D** Safety edges
- E** WES-ADJ module (via radio management of edges)
- F** WES sensors

LENGTH OF THE CABLE	< 10 metres	from 10 to 20 metres	from 20 to 30 metres
Power supply 230V	3G x 1,5 mm ²	3G x 1,5 mm ²	3G x 2,5 mm ²
Photocells (TX)	2 x 0,5 mm ²	2 x 0,5 mm ²	2 x 0,5 mm ²
Key switch	4 x 0,5 mm ²	4 x 0,5 mm ²	4 x 0,5 mm ²
Photocells (RX)	2 x 0,5 mm ²	2 x 0,5 mm ²	2 x 0,5 mm ²
Flashing light	2 x 1,5 mm ²	2 x 1,5 mm ²	2 x 1,5 mm ²
Antenna (integrated into the flashing light)	RG174	RG174	RG174

4 - CONTROL UNIT

PD20 is provided with a display that, not only makes programming simple, but also allows a continuous monitoring of the input statuses; in addition, thanks to a menu structure, the working schedule and the operation logic can be set easily.

In compliance with the European standards concerning electrical safety and electromagnetic compatibility (EN 60335-1, EN 50081-1 and EN 50082-1) it has been equipped with the low voltage circuit total electric insulation (motors included) from the network voltage.

Other characteristics:

- Speed regulation.
- Obstacle detection by monitoring motor current (amperometric) or encoder pulses.
- Automatic learning of the limit switch position
- Tests for safety devices (photocells, safety ribbons and triac) before each opening.
- Deactivation of safety inputs through the configuration menu: no jumper is required for terminals concerning safety devices that have not been installed, yet. You will only need to disable this function from its relevant menu.
- Synchronized operation of two motors using the SYNCRO optional module

 **Installation of control unit and safety devices must be carried out with power disconnected.**

4.1 - POWER SUPPLY

The control unit must be fed by a 230V - 50Hz electric line, protected by a differential magnetothermal switch complying with the law provisions in force.

Connect power supply cables to terminals **L** and **N** of PD20 control unit.

4.2 - FLASHING LIGHT

PD20 control unit provides for a 230V - 40W Flashing light equipped with intermittence inside.

Connect Flashing light cables to terminals **B1** and **B2** of the control unit.

4.3 - COURTESY LIGHTS

Thanks to the output COURTESY LIGHT the control unit allows the connection of an electric appliance (e.g. courtesy light or garden lights), controlled automatically or by means of the special transmitter key.

The output COURTESY LIGHT is a simple N.O. contact with no power supply.

Connect the cables to terminals **B3** and **B4**.

4.4 - ACTIVATION INPUTS

PD20 control unit is equipped with two activation inputs (START and START P.), whose operation depends on the programmed operation modes (see **Start** item of programming menu):

 **WARNING: If you use maintained command devices (magnetic loop detectors, timers, presence detectors, etc.) clock mode must be used (parameter Start = ONOL).**

Standard mode

START = START (a command will cause the complete opening of the gate)

START P. = PEDESTRIAN START (a command will cause the partial opening of the gate)

Open/Close command

START = OPENING (always controls the gate opening)

START P. = CLOSING (always controls the gate closing)

This is an impulse command, that is to say that an impulse will cause the complete gate opening or closing.

Manned operation

START = OPENING (always controls the gate opening)

START P. = CLOSING (always controls the gate closing)

This is a monostable command, that is to say, the gate will be opened or closed as long as the contact is closed and it will immediately stop as the contact is open

Timer mode

This feature allows you to program time slots during the day for the gate to be open by using an external timer or other maintained command devices (e.g. magnetic loop detectors or presence detectors).

START = START (a command will cause the complete opening of the gate)

START P. = PEDESTRIAN START (a command will cause the partial opening of the gate)

The gate stays open (completely or partially) while the contact is closed on input; as soon as the contact is open the pause time count down will start, after which the gate will be closed again.

ATTENTION: Automatic closing must be enabled

NOTE: If the parameter **P.RPP = 0** the timer connected to START P. does not cause the opening, but can inhibit the automatic closing at preset times.

In all modes, inputs must be connected to devices having normally open contacts.

Connect cables of device controlling the START input between terminals **M1** (START) and **M4** (COM) of the control unit.

Connect cables of device controlling the START P. input between terminals **M2** (START P.) and **M4** (COM) of the control unit.

The START input function can also be activated by pressing **↑** key (outside the programming menu) or by means of a remote control stored on channel 1 of MR receiver.

The START P. input function can also be activated by pressing **↓** key (outside the programming menu) or by means of a remote control stored on channel 2 of MR receiver.

4.5 - STOP

For a better safety, you can fit a stop switch that will cause the immediate gate stop when activated. This switch must have a normally close contact that will get open in case of operation.

In case the stop switch is operated while the gate is open, the automatic closing function will always be disabled. To close the gate again, you will need a start command.

Connect the stop switch cables between terminal **M3** and **M4** of the control unit.

The STOP switch function can be activated by means of a remote control stored on channel 3 of MRx receiver

4.6 - PHOTOCELLS

The control unit considers two kinds of photocells, depending on the terminal to which they are connected:

Photocell 1

Photocells installed on the gate inner side, which are active both during the opening and the closing phase. When photocells 1 operate, the control unit stops the gate; as soon as the photocell beam is free, the control unit will open the gate completely.

 **WARNING: Type 1 photocells must be installed so that they completely cover the opening area of the gate.**

Photocell 2

Photocells installed on the external gate side and which are active during the closing phase only. When photocells 2 operate, the control unit opens the gate immediately, without waiting for release.

PD20 control unit supplies a 24VAC power supply to photocells and it can perform a photocell operation test before starting the gate opening phase. Photocell power terminals are protected by an electronic fuse that stops current in case of overload.

- Connect power supply cables of photocells transmitter between terminals **M11** and **M12** of the control unit.
- Connect power supply cables of photocells receiver between terminals **M10** and **M11** of the control unit.
- Connect receiver output of photocells 1 between terminals **M5** and **M9** of the control unit and receiver output of photocells 2 between terminals **M6** and **M9** of the control unit.
Use outputs having normally closed contact.

 **ATTENZIONE:**

- If several couples of same kind photocells are mounted, their outputs must be connected in series.
- In case of reflection photocells, power supply must be connected to terminals **M11** and **M12** of the control unit to carry out the operation test.

4.7 - SAFETY RIBBONS

The control unit considers two kinds of safety ribbons, depending on the terminal to which they are connected:

Type 1

When type 1 safety ribbons operate during the gate opening phase, the control unit will close the doors for 3 seconds, then it stands still; when type 1 safety ribbons operate during the gate closing phase, the control unit will stand still immediately. The direction of the gate at next command of START or PEDESTRIAN START depends upon the parameter STOP (it inverts or continues the motion).
If the input STOP is disabled, the command makes the motion continue in the same direction.

Type 2

when type 2 safety ribbons operate during the gate opening phase, the control unit will stand still immediately; when type 2 safety ribbons operate during the gate closing, the control unit will open the doors for 3 seconds, then it will stand still. The direction of the gate at next command of START or PEDESTRIAN START depends upon the parameter STOP (it inverts or continues the motion). If the input STOP is disabled, the command makes the motion continue in the same direction.

Both the input can manage the classic safety edge with n.c. contact and the conductive rubber safety edge with 8,2 kohm nominal resistance.

Connect type 1 safety ribbons cables between terminals **M7** and **M9** of the control unit.

Connect type 2 safety ribbons cables between terminals **M8** and **M9** of the control unit.

In order to meet the requirements of the EN12978 rules, it is necessary to install safety edges controlled by a control unit continuously checking the proper working. If using control units suited to the test by power outage, connect the power supply cables of the control unit between terminals **M11** and **M12** of the control unit.
Otherwise, connect them between terminals **M10** and **M11**.

 **WARNING:**

- Make use of safety ribbons having outputs with normally close contact.
- Outputs of same kind safety ribbons must be connected in series.

4.8 - EXTERNAL AERIAL

We suggest to use the external aerial (model: ANS433) in order to guarantee the maximal range.

Connect the antenna hot pole to terminal **A2** of the control unit and the braiding to terminal **A1**.

 **WARNING: the versions with the aluminum cover have a limited radio range due to the shielding of the cover. To improve the reception is recommended the installation of an outdoor antenna.**

4.9 - ELECTRICAL CONNECTION

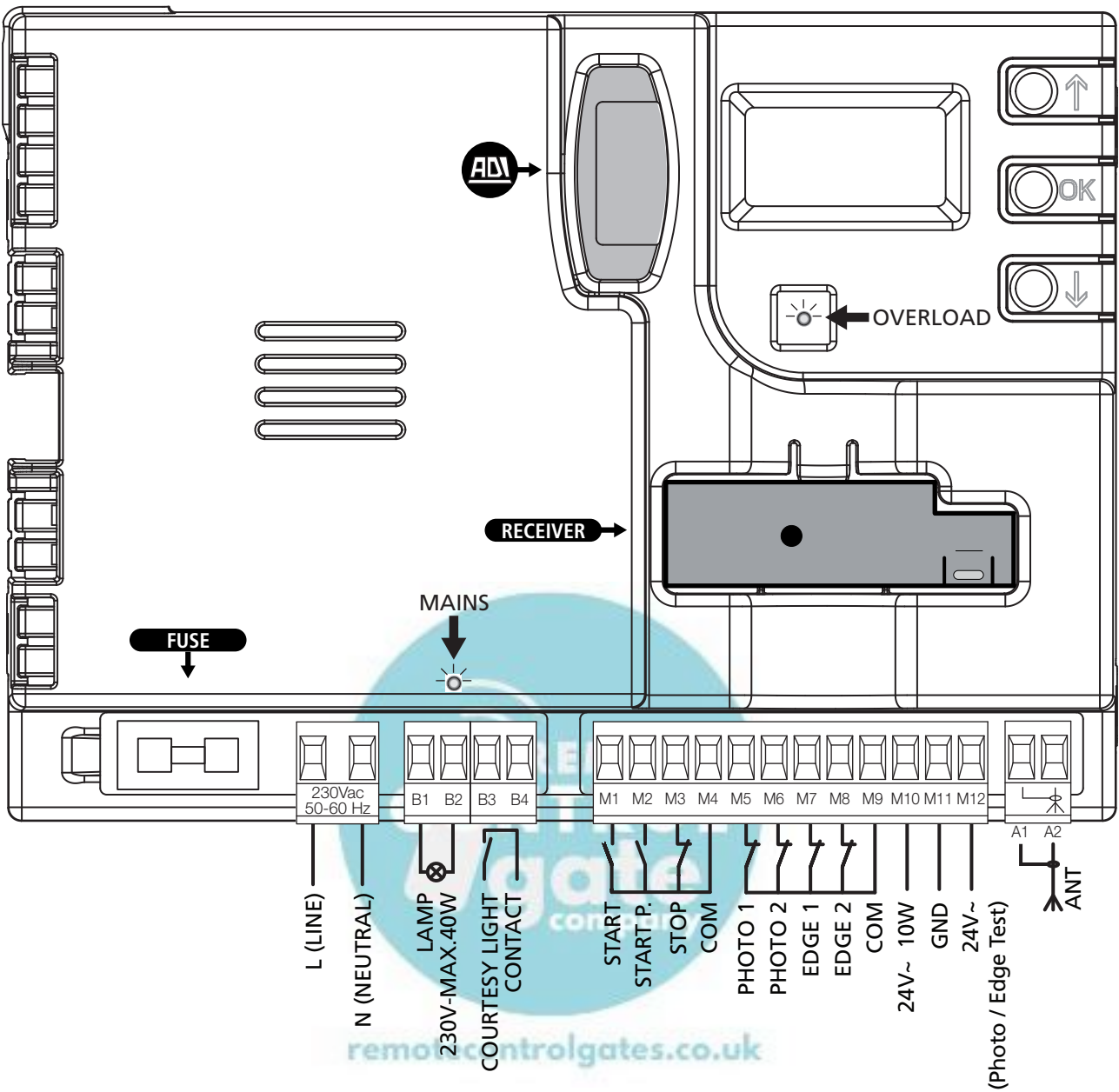

⚠ Connect the motor to ground through the clamp marked by the symbol . Use the eyelet provided.

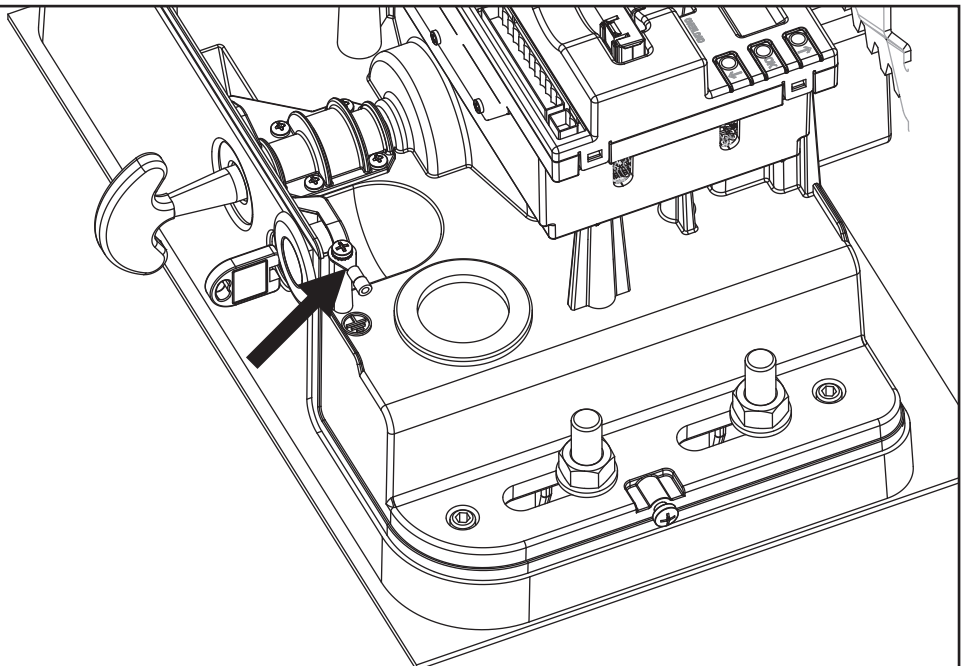

L	Power phase 230 VAC
N	Neutral 230 VAC
B1 - B2	Flashing light 230VAC - 40W
B3 - B4	Courtesy light
M1	START - Open command for connecting traditional devices with N.O. contact ⚠ WARNING: If you use maintained command devices (magnetic loop detectors, timers, presence detectors, etc.) clock mode must be used (parameter Start = orol).
M2	START P. - Pedestrian open command for connecting traditional devices with N.O. contact ⚠ WARNING: If you use maintained command devices (magnetic loop detectors, timers, presence detectors, etc.) clock mode must be used (parameter Start = orol).
M3	STOP command. N.C. contact
M4	Common (-)
M5	Photocell 1. N.C. contact
M6	Photocell 2. N.C. contact
M7	Type 1 edges. N.C. contact
M8	Type 2 edges. N.C. contact
M9	Accessories common (-)
M10	24VAC supply for photocells and other accessories
M11	Accessory power common (-)
M12	24VAC supply - photocell/optical edge TX for functional Test. Connect power supply cables of photocells transmitter between terminals M11 and M12
A1	Antenna shield
A2	Antenna

ADI	ADI module interface
RECEIVER	Plug-in receiver
FUSE	8A
MAINS	It shows that the control unit is power supplied
OVERLOAD	It shows that there is an overload on accessories power supply

4.10 - PLUG IN RECEIVER

PD20 control unit is suitable for plugging in a MRx receiver having a high-sensitivity super-heterodyne architecture.

⚠ WARNING: Pay attention to the way you connect the removable modules.

MRx module receiver is provided with 4 channels and each of them is suitable for a command of PD20 control unit:

- CHANNEL 1 → START
- CHANNEL 2 → PEDESTRIAN START
- CHANNEL 3 → STOP
- CHANNEL 4 → COURTESY LIGHT

NOTE: Before programming 4 channels and function logics read carefully the instructions of MRx.

4.11 - ADI INTERFACE

The ADI (Additional Devices Interface) interface of the control unit PD20 allows the connection to V2 optional modules.

Refer to V2 catalogue or to the technical sheets to see which optional modules with ADI interface are available for this control unit.

⚠ WARNING: Please read the instructions of each single module to install the optional modules.

For some devices, it is possible to configure the mode for interfacing with the control unit; in addition, it is necessary to enable the interface so that the control unit can process the signals arriving from the ADI device.

Please refer to the **ADI** programming menu to enable the ADI interface and access the device configuration menu. ADI devices use the display of the control unit to issue alarms or display the configuration of the control unit.

The device connected to the AdI interface is able to signal to the control unit three alarm signals, which are displayed on the control unit display as follows:

- PHOTOCELL ALARMS - the upper segment comes on: the gate stops moving, when the alarm stops opening restarts.
- EDGE ALARM - the lower segment comes on: inverts motion of the gate for 3 seconds.
- STOP ALARM - both segments start flashing: the gate stops and cannot restart until the alarm stops.
- SLAVE - segment steadily lit: it is used by the optional module SYNCRO to indicate that the control unit is configured as SLAVE.

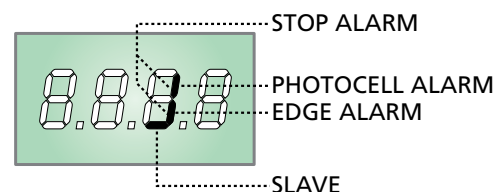

5 - CONTROL PANEL

5.1 - DISPLAY

When power is on, the control unit checks that display correctly operates by switching on all segments for 1.5 sec. **8.8.8.8**. Firmware version, e.g. **Pr 1.0**, will be viewed in the following 1.5 sec.

Panel will be viewed upon completion of this test.

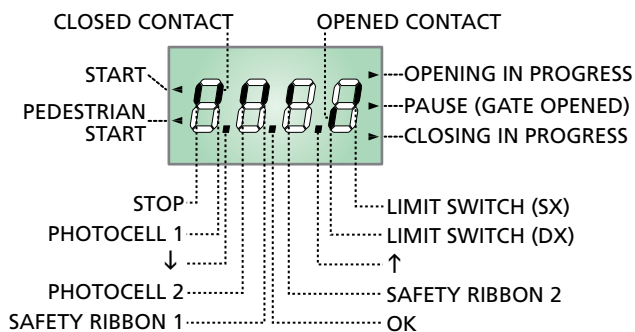

The control panel represents the physical status of the terminal board contacts and of the program mode keys: if the upper vertical segment is on, the contact is closed; if the lower vertical segment is on, the contact is open (the above picture shows an instance where the inputs PHOTO1, PHOTO2, EDGE1, EDGE2 and STOP have all been correctly connected).

NOTE: if you are using an ADI module, other segments may appear on the display, see the paragraph dedicated to the "ADI INTERFACE"

Points being among display digits show the status of programming push-buttons: as soon as a push-button is pressed, its relevant point turns on.

The arrows on the left of the display show the state of the start inputs. The arrows light when the related input is closed.

The arrows on the display right side show the gate status:

- The highest arrow turns on when the gate is into its opening phase. If it blinks, it means that the opening has been caused by a safety device (border or obstacle detector).
- The central arrow shows that the gate is on pause. If it blinks, it means that the time countdown for the automatic closing has been activated.
- The lowest arrow blinks when the gate is into its closing phase. If it blinks, it means that the closing has been caused by a safety device (border or obstacle detector).

5.2 - USE OF THE KEYS FOR PROGRAMMING

The control unit functions and times are programmed by means of a special configuration menu, which can be accessed and explored by using the 3 keys, **↑**, **↓** and **OK**, located on the side of the control unit display.

PLEASE NOTE: Outside the configuration menu, pressing the **↑ key activates the START command, pressing the **↓** key activates the PEDESTRIAN START command.**

There are the following three kinds of menu items:

- Function menu
- Time menu
- Value menu

Function menu setup

Function menus allow selecting a function from among a group of available options. When you enter into a function menu, the current active option will be viewed; you can scroll all available options through **↓** and **↑** keys. By pressing the **OK** key, you will activate the option viewed and you will return to the configuration menu.

Time menu setup

Time menus allow setting a function duration. When you enter into a time menu, the current setup value will be viewed; the display mode depends on the current value:

- Each time you press **↑** key, current time value increases and each time you press the **↓** key, current time value decreases.
- By holding down the **↑** key, you can quickly increase the time value, up to reach the max. value allowed for this item.
- Vice versa, by holding down the **↓** key, you can quickly decrease the time value down to reach **0.0"**
- In some circumstances, setting the value to **0** means that the relevant function is disabled, in this case, **no** will appear instead of **0.0"**
- By pressing on **OK** you will confirm the displayed value and you will return to the configuration menu.

Value menu setup

Value menus are similar to time menus; however, the setup value can be any number.

By holding down **↑** or **↓** keys, the value will increase or decrease slowly.

By pressing on **OK** you will confirm the displayed value and you will return to the configuration menu.

The main programming menus of the control unit are shown in the next pages.

To go through the menus use the three keys **↑**, **↓** and **OK** according to the following chart:

	Press and release the push-button OK
	Keep pressed the push-button OK for 2 seconds
	Release the push-button OK
	Press and release the push-button ↑
	Press and release the push-button ↓

6 - ACCESSING THE CONTROL UNIT SETTINGS

1. Press and hold the **OK** key until the display shows the menu desired
2. Release the **OK** key: the display will show the first item in the sub-menu
 - **Prg** Programming the control unit (chapter 13)
 - **Cnt** Cycle counter (chapter 12)
 - **APP** Self-learning of working times (chapter 9)
 - **Inu** Inverter board functional test (chapter 10)
 - **dEF** Loading the default parameters (chapter 8)

⚠ WARNING: in case no operation is carried out for more than one minute, the control unit exits from the programming mode without saving any of your setups and changes, which will get lost.

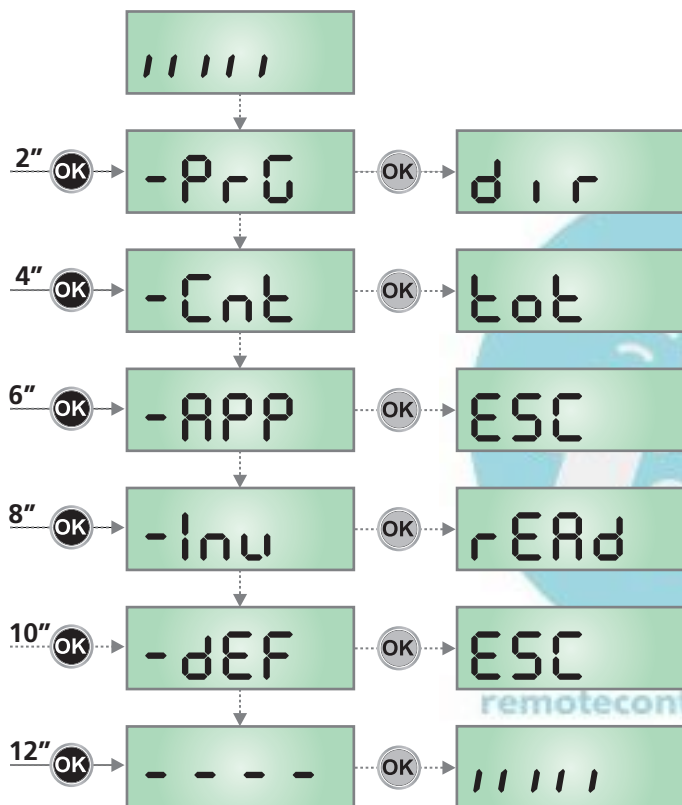

7 - QUICK CONFIGURATION

This paragraph concerns a quick procedure to set the control unit and set it at work immediately.

We recommend following these instructions, in order to check quickly the correct operation of control unit, motor and accessories, and then changing the configuration in case of any non-satisfactory parameter.

1. Call up the default configuration: see chapter 8
2. Set items **dir** - **StoP** - **FoEt1** - **FoEt2** - **CoS1** - **CoS2** according to the safety devices installed on the gate. For the position of the item menus inside the main menu and for the options related to each item menu, refer to the chapter 13
3. Start the self-learning cycle: see chapter 9 (SELF-LEARNING OF WORKING TIMES)
4. Check that the automation work properly and if necessary modify the configuration of the desired parameters

8 - LOADING THE DEFAULT PARAMETERS

If necessary, it is possible to restore all parameters to their standard or default values (see the final summary table).

⚠ PLEASE NOTE: This procedure results in the loss of all customised parameters.

1. Press and hold the **OK** key until the display shows **-dEF**
2. Release the **OK** key: the display shows **ESC** (only press the **OK** key if it is desired to exit this menu)
3. Press the **↓** key: the display shows **dEF.**
4. Press the **OK** key: the display shows **no**
5. Press the **↓** key: the display shows **S1**
6. Press the **OK** key: all parameters are overwritten with their default values (see Chapter 13), the control units exits programming mode and the display shows the control panel.

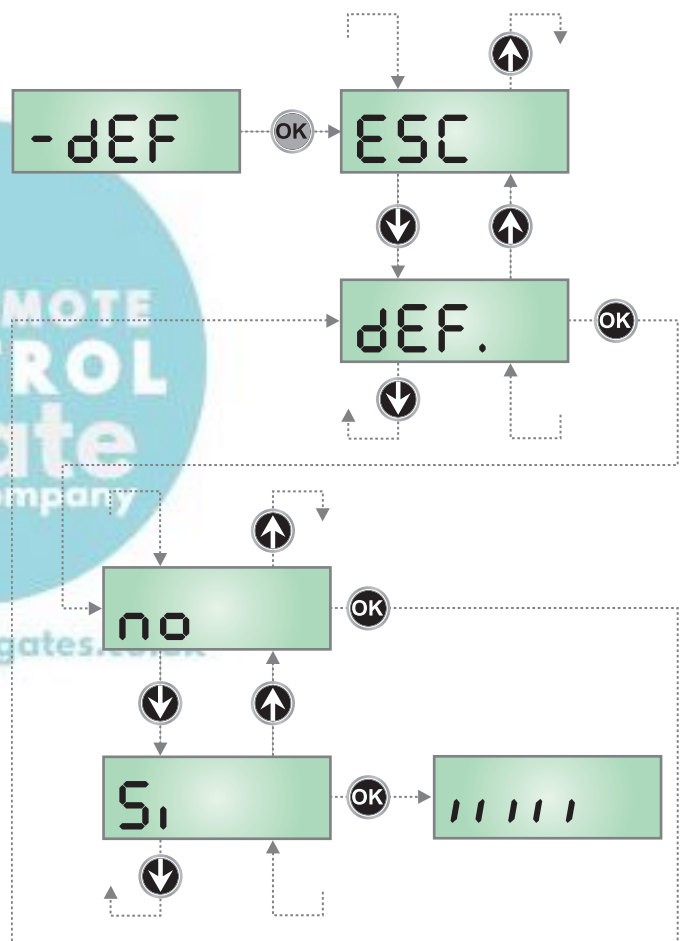

9 - SELF-LEARNING OF WORKING TIMES

This menu allows the automatic learning of the times necessary to open and close the gate.

During this phase, the control unit memorizes also the forces necessary to open and close the gate: these values will be activated by using the obstacle sensor.

⚠ CAUTION: to perform the self-learning procedure it is necessary to disable the ADI interface by means of the menu i.Adi.

If some safeties are controlled by means of the ADI module, they will not be active during the self-teaching stage.

⚠ CAUTION: ATTENTION: before proceeding, make sure to position the mechanical stops and the limit sensors correctly.

1. Press and hold the **OK** key until the display shows **-APP**
2. Release the **OK** key: the display shows **ESC** (only press the **OK** key if it is desired to exit this menu)
3. Press the **↓** key: the display shows **ε.LRu**
4. Press the **OK** key to activate the working time self-training cycle: the display shows the control panel and starts the time self-training procedure.
 - 4.1 The gate will be activated in closing direction until the stop end or the closing end of stroke is reached
 - 4.2 The gate will be activated in opening direction until the stop end or the opening end of stroke is reached
 - 4.3 The gate will be activated in closing direction until the stop end or the closing end of stroke is reached

⚠ CAUTION: during self-learning stage of times, the motor moves at reduced speed.

5. If the AMPEROMETRIC obstacle sensor was enabled, the display shows the suggested value for sensor threshold. If no operations are performed for 20 seconds, the control unit exits the programming phase, without saving the value recommended.
6. The recommended value may be modified by pressing the **↑** and **↓** keys, and pressing the **OK** key confirms the displayed value and the display shows **SEn.A**
7. Press and hold the **↓** key until the display shows **FinE**, then press the **OK** key, select the option **Si** and then press the **OK** key to exit programming mode, storing the value for the sensors.

⚠ PLEASE NOTE: If the control unit is left to time out from programming mode (1 minute), the obstacle sensor return to the value that was set prior to performing self-training (according to the default values, the sensor is disabled).

On the other hand, the limit switch positions are always stored.

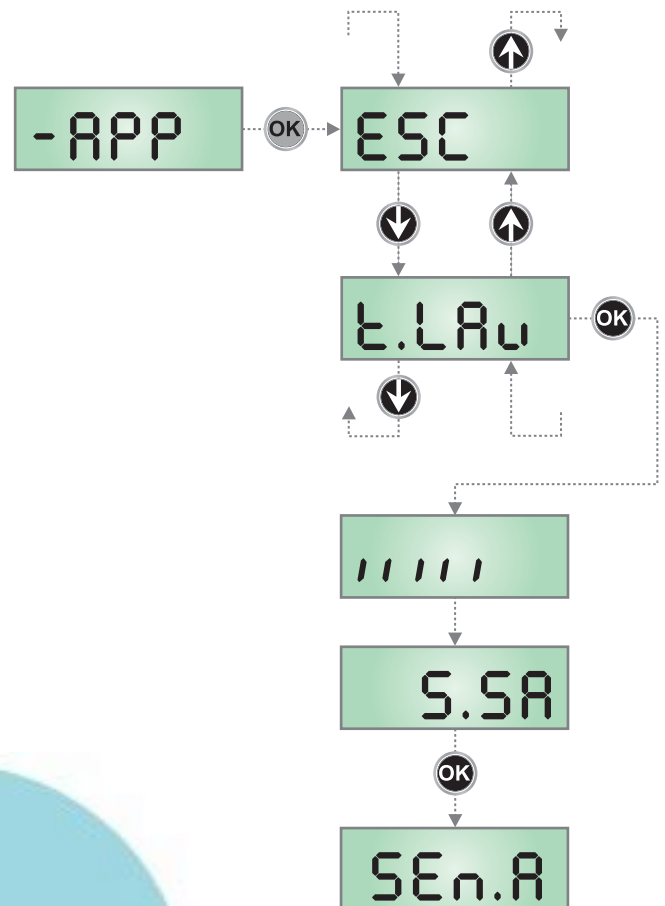

10 - INVERTER BOARD FUNCTIONAL TEST

This menu allows you to perform a functional test on the INVERTER board.

1. Hold down the **OK** button until the display shows **-inu**
2. Release the **OK** button: the display shows **rERd**
3. If the inverter board works properly after a few seconds the display shows the firmware version of the board.

NOTE: at this stage with the keys **↑** and **↓** you can access the diagnostics menu.

Consult these menus only as directed by V2 Technical Support.

4. Press the **OK** button: the control unit exits programming and the display shows the control panel
5. If the display continues to display **rERd**, it means that the INVERTER board is not working properly. Refer to the V2 Technical Support.

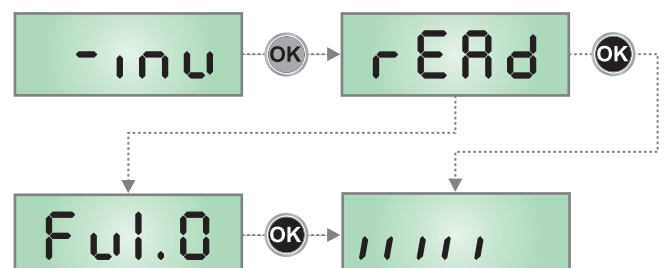

11 - EMERGENCY DEAD MAN OPERATION

This operational mode can be used to move the gate in DEAD MAN mode in particular cases, such as installation/maintenance or in the case of malfunctioning of photocell, edge, limit switches or encoder.

To activate the function the START command must be pressed 3 times (presses must last at least 1 second; the pause between commands must last at least 1 second).

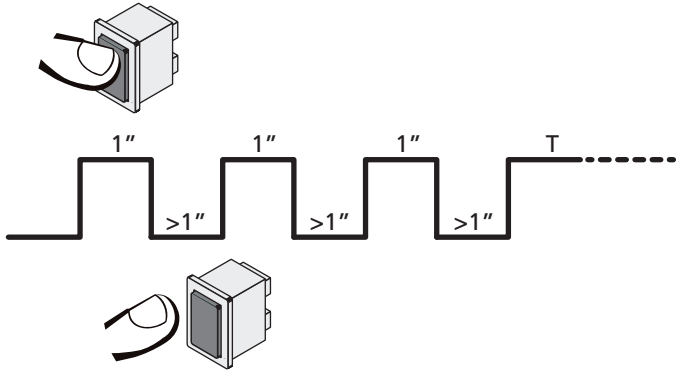

The fourth START command activates the gate in MAN PRESENT mode. To move the gate keep the START command pressed for the duration of the operation (time T). The function will automatically turn off after 10 seconds of inactivity of the gate.

NOTE: if the **StEt** parameter is set as **StErn**, the Start command (from the terminal block or remote control) moves the gate in the open and closed directions alternatively (unlike the normal DEAD MAN mode).

12 - READING OF CYCLE COUNTER

PD20 control unit counts the completed opening cycles of the gate and, if requested, it shows that service is required after a fixed number of cycles.

There are two counters available:

- A totalizing counter for completed opening cycles that cannot be zeroed (option **tot** of item **Cont**)
- A downward counter for the number of cycles before the next request for service (option **SEru** of item **Cont**).

This counter can be programmed according to the desired value. The scheme hereafter shows how to read the totalizing counter, how to read the number of cycles before the next service is required as well as how to program the number of cycles before the next request for service (as for the example shown, the control unit completed no. 12451 cycles and there are no. 1300 cycles before the next service request).

Area 1 is the reading of the total number of completed cycles; through \uparrow and \downarrow keys, you can alternate the display of thousands or units.

Area 2 is the reading of the number of cycles before the next request for service: its value is rounded down to the hundreds.

Area 3 is the setup of this latter counter; on first pressing the \uparrow or \downarrow key the current value of the counter is rounded to the thousand, each press after this increases the setting by 1000 units or decreases by 100. The previous displayed count will get lost.

12.1 - SIGNAL OF SERVICE REQUIRED

As soon as the counter of cycles before the next request for service is zero, the control unit shows the request for service through an additional 5-second pre-blinking.

This signal will be repeated at each opening cycle, until the installer enters into the counter reading and setup menu, and possibly programs the number of cycles after which the next service will be requested.

In case no new value is setup (that is to say that the counter value is left at zero), the signalling function for the service request will be disabled and no signal will be repeated anymore.

WARNING: service operations shall be carried out by qualified staff only.

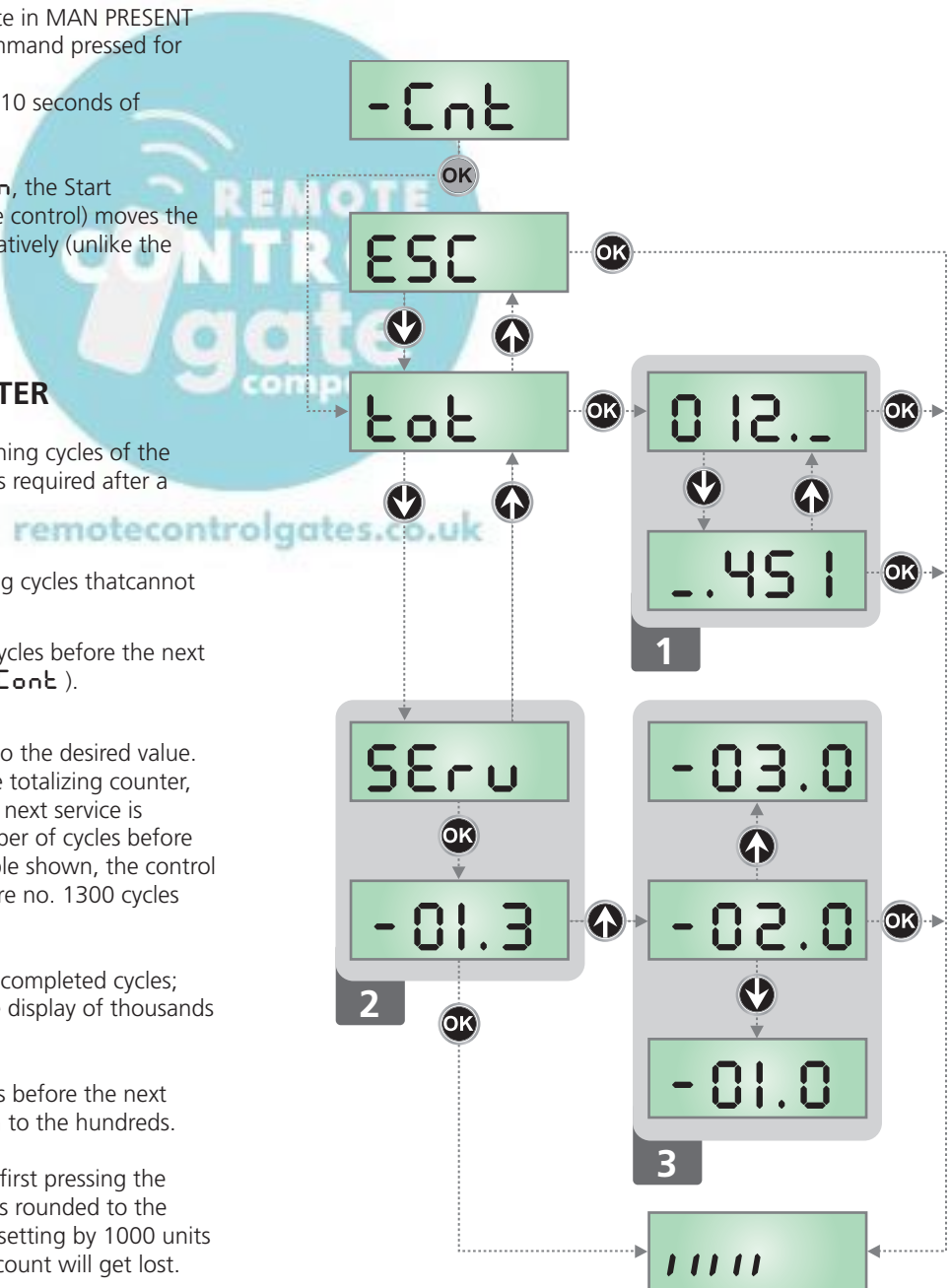

13 - PROGRAMMING THE CONTROL UNIT

The configuration menu **-PrG** consists in a list of configurable items; the display shows the selected item.

By pressing **↓**, you will pass to the next item; by pressing **↑**, you will return to the previous item.

By pressing **OK**, you can view the current value of selected item and possibly change it.

The last menu item (**FinE**) allows storing the carried out changes and going back to the control unit normal operation.

You must exit from programming mode through this menu item if you do not want to lose your configuration.

⚠ WARNING: in case no operation is carried out for more than one minute, the control unit exits from the programming mode without saving any of your setups and changes, which will get lost.

By holding down the **↓** or **↑** keys, configuration menu items will scroll fast, until item **FinE** is viewed.

In this way, you can quickly reach either the top or bottom of the list.

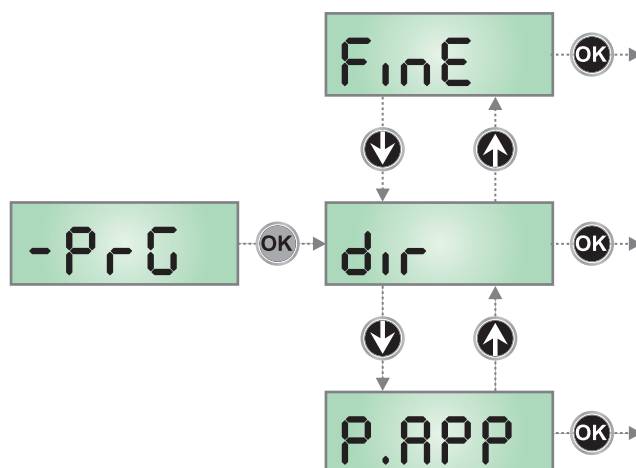

PARAMETER	VALUE	DESCRIPTION	DEFAULT	MEMO
dir		Gate direction (the direction you see from the inside)	dH	
	dH	The gate opens rightwards		
	SH	The gate opens leftwards		
P.APP		Partial opening	25	
	0 - 100	The percentage of the path the gate performs in the case of opening using the Pedestrian Start command		
t.PrE		Pre-blinking time	1.0"	
	0.5" - 1'00	Before any gate movement, blinker will be activated for t.PrE time, to warn about the incoming motion (adjustable time from 0.5" to 1'00)		
	no	Function deactivated		
t.PCh		Different closing pre-flashing time	no	
	0.5" - 1'00	If this parameter has a value assigned to it, the control unit will activate pre-flashing prior to closure for the length of time set in this menu (adjustable time from 0.5" to 1'00)		
	no	The closing pre-flashing time corresponds to t.PrE		
vEL		Speed during normal operation	18.0	
	3.5 - 35.0	This menu allows you to adjust gate speed during normal operation. The value shown is in cm/s		
vEL.r		Speed during slowdown	6.0	
	3.5 - 35.0	This menu allows you to adjust gate speed during slowdown. The value shown is in cm/s		
		NOTE: The maximum value which can be set is equal to the value set in the menu vEL		
rAm		Starting ramp	4	
	0 - 6	In order not to stress too much the motor, when the motion starts the power is gradually increased, until reached the set value or 100% if the take-off is enabled. Higher is the set value, longer the length of time of the ramp, that is the time necessary to reach the value of nominal power.		

PARAMETER	VALUE	DESCRIPTION	DEFAULT	MEMO
FrEn		Brake Function	5	
	1 - 10	When a sliding motor is used with a very heavy gate, because of the inertia, the gate does not block immediately when stopped and its motion can last for another 10 cm, compromising the working of the safety devices. This menu allows enabling the brake function thanks to which it is possible to block immediately the gate after a control or the intervention of a safety device. The brake power is proportional to the set value WARNING: each braking entails a mechanical stress to the components of the motor. We suggest to set the minimum value with which there is a satisfactory stop distance.		
	0	Function deactivated		
SEn.A		Enabling the AMPEROMETRIC obstacle sensor	0.0A	
	0.0A - 5.0A	When the power absorbed by the motor exceeds the level set, an alarm goes off in the power unit. If 0.0A is set, the function is disabled. When the sensor intervenes, the gate stops and is operated in the reverse direction for 3 seconds to remove the obstacle. The next start command restarts the movement in the previous direction.		
SEn.u		Enabling the SPEED obstacle sensor	3	
	0 - 9	When motor speed drops below the set value, the control unit raises an alarm. The value shown is in cm/s When the sensor intervenes, the gate stops and is operated in the reverse direction for 3 seconds to remove the obstacle. The next start command restarts the movement in the previous direction.		
rR.AP		Slow down in opening	15	
	0 - 100	This menu allows regulating the percentage of the ride/drive that is carried out at reduced speed during the last opening stretch		
rR.Ch		Slow down in closing	15	
	0 - 100	This menu allows regulating the percentage of the ride/drive that is carried out at reduced speed during the last closing stretch		
SE.AP		Start command during the opening phase This menu allows fixing the control unit conduct in case it receives a Start command during the opening phase	PAUS	
	PAUS	The gate stops and goes to pause		
	ChU	The gate immediately starts closing		
	no	The gate go on with the opening phase (command is ignored)		
SE.Ch		Start command during the closing phase This menu allows fixing the control unit conduct in case it receives a Start command during the closing phase	StoP	
	StoP	The gate stops and its cycle is considered as finished		
	APEr	The gate opens again		
SE.PA		Start command during the pause This menu allows fixing the control unit conduct in case it receives a Start command when the gate is open during its pause phase	ChU	
	ChU	The gate starts closing		
	no	Command is ignored		
	PAUS	The pause time is reset (Ch.RU)		

PARAMETER	VALUE	DESCRIPTION	DEFAULT	MEMO
SP.AP		Pedestrian Start during the partial opening phase This menu allows fixing the control unit conduct in case it receives a Pedestrian Start command during the partial opening phase. WARNING: a Start command in any phase of partial opening will cause the total opening; the Start Pedestrian command is always ignored during a total opening	PAUS	
	PAUS	The gate stops and goes to pause		
	Ch.U	The gate immediately starts closing		
	no	The gate goes on with the opening phase (command is ignored)		
Ch.AU		Automatic closing In automatic mode, the control unit automatically recloses the gate on expiry of the time limit set in this menu	no	
	no	Function deactivated		
	0.5" - 20.0'	The gate recloses after the set time (adjustable time from 0,5" to 20.0')		
Ch.Er		Closure after passage During the automatic operation, the pause count down starts from the set up value each time a photocell operates during the pause. If the photocell operates during the opening time, this time will be immediately stored as pause time. This function allows having a fast closing as soon as transit through the gate is completed, therefore, a time shorter than Ch.AU is generally used	no	
	no	Function deactivated		
	0.5" - 20.0'	The gate recloses after the set time (adjustable time from 0,5" to 20.0')		
PA.Er		Pause after transit	no	
	Si	In order to let the gate open for the shortest possible time, it is possible to stop the gate once the passage before the photocells is detected. If the automatic working is enabled, the time of the pause is Ch.Er		
	no	Function deactivated		
LUCi		Courtesy lights This menu allows setting the automatic operating of the courtesy lights during the opening cycle of the gate	E.LUC	
	E.LUC	Timed function (from 0 to 20')	1'00	
	no	Function deactivated		
	Ci.CL	On for the entire duration of the cycle		
AUS		Auxiliary channel This menu allows setting the operating of the relay of the lighting of the courtesy lights by means of a remote control stored on the channel 4 of the receiver	Mon	
	E.iM	Timed function (from 0 to 20')		
	biStE	Bistable operation		
	Mon	Monostable operation		
LP.PA		Blinker during pause time	no	
	no	Function deactivated		
	Si	The blinker will be on during the pause time too (gate open with automatic closure active)		

PARAMETER	VALUE	DESCRIPTION	DEFAULT	MEMO
StArE		Activation inputs function This menu allows selecting input operation modes (see chapter 4.4)	StArn	
	StArn	Standard mode		
	no	Start inputs from terminal board are disabled. Radio inputs operate in standard mode StArn		
	AP.Ch	Open/Close command		
	PrES	Manned operation		
	oroL	Timer mode		
StoP		Stop input	no	
	no	The input STOP is not available (ignored by the control unit)		
	ProS	The input STOP stops the gate: pressing the command START the gate continues the motion		
	inuE	The command STOP stops the gate: at the next START the gate starts moving in the opposite direction		
Fot1		Photocell 1 input This menu allows enabling the input for type 1 photocells, that is to say, photocells active both during the opening and closing phase	no	
	no	Input disabled (ignored by the control unit)		
	AP.Ch	Input enabled		
Fot2		Photocell 2 input This menu allows enabling the input for type 2 photocells, that is to say, photocells non active during the opening phase	CFCh	
	CFCh	Input enabled even at standstill gate too: the opening movement does not start if photocell is interrupte		
	Ch	Input enabled for the closing phase only WARNING: if you select this option, you must disable photocell test		
	no	Input disabled (ignored by the control unit)		
Ft.tE		Test of the photocells	no	
	no	Function deactivated		
	Si	In order to achieve a safer operation for the user, the unit performs a photocells operational test, before a normal working cycle. If no operational faults are found, the gate starts moving. Otherwise, it will stand still and the flashing light will stay onfor 5 sec. The whole test cycle lasts less than one second.		
CoS1		Safety ribbon 1 input This menu allows enabling the input for type 1 safety ribbon, that is to say, fixed ribbons	no	
	no	Input disabled (ignored by the control unit)		
	APCh	Input enabled in opening and closure		
	AP	Input enabled during the opening and disabled during the closure		
CoS2		Safety ribbon 2 input This menu allows enabling the input for type 2 safety ribbon, that is to say mobile ribbons	no	
	no	Input disabled (ignored by the control unit)		
	APCh	Input enabled in opening and closure		
	Ch	Input enabled during closure and disabled during opening		

PARAMETER	VALUE	DESCRIPTION	DEFAULT	MEMO
Co.tE		Test of the safety edges This menu allows setting the method of control of the safety edges working	no	
	no	Test disabled		
	rESi	Test enabled for conductive rubber safety edges		
	Foto	Test enabled for optical safety edges		
i.Rd1		Enabling the ADI device This menu makes it possible to enable operation of the device connected to the ADI connector. PLEASE NOTE: selecting S1 and pressing MENU accesses the configuration menu for the device connected to the ADI connector. This menu is managed by the device itself and is different for each device. Please refer to the manual for the device. If the S1 option is selected, but no device is connected, the display will show a series of dotted lines. Exiting the ADI device configuration menu returns to the i.Rd1 option	no	
	no	Interface disabled, any signals will be ignored		
	S1	Interface enabled		
FinE		End of Programming This menu allows to finish the programming (both default and personalized) saving the modified data into memory	no	
	no	Do not quit the programming		
	S1	End of programming		

14 - OPERATION DEFECTS

This paragraph shows some possible operation defects, along with their cause and applicable remedy.

MAINS led does not switch on

It means that there is no voltage on PD20 control unit card.

1. Before acting on the control unit, disconnect through the disconnecting switch on the power line and remove the power supply terminal.
2. Be sure that there is no voltage break upstream the control unit.
3. Check whether the fuse is burnt-out, if so replace it with same value.

OVERLOAD led is on

It means that there is an overload on accessory power supply.

1. Remove the extractable part containing terminals M1 to M12. OVERLOAD led will switch off.
2. Remove the overload cause.
3. Reinsert the terminal board extractable part and check that this led is not on again.

Too long pre-blinking

When a Start command is given and the blinker switches on immediately but the gate is late in opening, it means that the setup cycle count down expired and the control unit shows that service is required.

Slow movement of the gate while closing

This condition can occur when the motor encoder must be realigned: the gate is closed at slow speed until the closed range limit and after resumes normal operation.
This anomaly can occur due to power failure with the gate open or due to other factors related to the malfunctioning of the gate.

Error 1

The following writing appears on display when you exit from programming **Err1**
It means that changed data could not be stored.
This kind of defect has no remedy and the control unit must be sent to V2 S.p.A. for repair.

Error 2

When a Start command is given and the gate does not open and the following writing appears on display **Err2**
This indicates an error in the inverter board operation.
NOTE: If the motor has been heavily used, the motor driver may have overheated. Let it cool and try again.

Error 3

When a Start command is given and the gate does not open and the following writing appears on display **Err3**

It means that the photocell test failed.

1. Be sure that no obstacle interrupted the photocell beam when the Start command was given.
2. Be sure that photocells, as enabled by their relevant menus, have been installed actually.
3. If you have photocells 2, be sure that **Fot2** menu item is on **CF.Ch**.
4. Be sure that photocells are powered and working; when you interrupt their beam, you should hear the relay tripping.

Error 4

When a Start command is given and the gate does not open (or does a partial opening) and the following writing appears on display **Err4**

This anomaly can occur when in one of the following conditions:

1. If a START command is sent with the motor released.
2. During the self-learning cycle if there are any problems with the range limits.
Check the direction of the magnets, if they are backwards, they should be removed and inverted.
If the magnets are installed correctly, it means that the limit switch sensor is damaged or the cabling connecting the sensor to the central control unit is broken/damaged.
Change the end of stroke sensor or the broken wiring.
3. During normal operation. If the error persists send the control unit to V2 S.p.A. for repair.

Error 5

Once given a start control, the gate does not open and the display shows **Err5**

It means that the test of the safety edges failed.

Check that the menu of the test of safety edges (Co.tE) have been set correctly.

Check that the safety edges enabled from the menu are installed.

Error 6

During the manoeuvre the motor stops and the display shows **Err6**

It means that there are communication problems with the inverter board. If the problem persists, the control unit must be sent to V2 SpA for repair.

Error 7

When given a start control the gate does not open and the display shows **Err7**

This indicates an error in the encoders' operation.

Encoder malfunction or broken connection.

Error 8

When executing a self-learning function, one of the following conditions occurs:

1. the control is refused and the display shows **Err8**
It means that the setting of the control unit is not compatible with the requested function.
In order to carry out self-learning, the Start inputs must be enabled in standard mode (**SErE** menu set to **SEAn**) and the ADI interface must be disabled (**i.Adi** menu set to **no**).
2. The procedure stops and the displays shows **Err8**
It means that a safety device has tripped.

Error 9

When you are trying to change the control unit setups and the following writing appears on display **Err9**

It means that programming was locked by means of the programming lock key CL1+ (code 161213).

To change the settings it is necessary to insert in the connector of the ADI interface the same key used to activate the programming lock, and unlock the device.

Error 10

When a start command is given, the gate does not open and the display shows the message **Er 10**

This means that the ADI module function test failed

Error 12

When a Start command is given and the gate does not open (or does a partial opening) and the following writing appears on display **Er 12**

This means the motor overheating protection has tripped.

The system will start working again as soon as the motor has cooled.

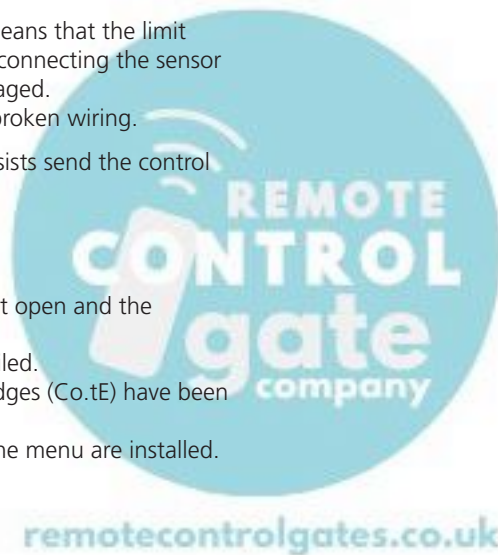

15 - TESTING AND START-UP

In implementing the automation device, these are the most important steps for guaranteeing maximum safety.

V2 recommends the application of the following technical standards:

- EN 12445 (Safety in the use of automated closures, test methods)
- EN 12453 (Safety in the use of automated closures, requirements)
- EN 60204-1 (Safety of Machinery, electrical equipment of machines, part 1: general principles)

In particular, with reference to the table in the section "PRELIMINARY CHECKS and IDENTIFICATION OF THE TYPE OF USE" in the majority of cases, it will be necessary to measure the impact force, in accordance with the provisions of EN 12445.

Adjusting the operating force is possible by programming the electronic circuit board, and the impact force profile should be measured using an appropriate device (itself also certified and subjected to annual calibration) capable of tracing the force-time graph.

The result should be in compliance with the following maximum values:

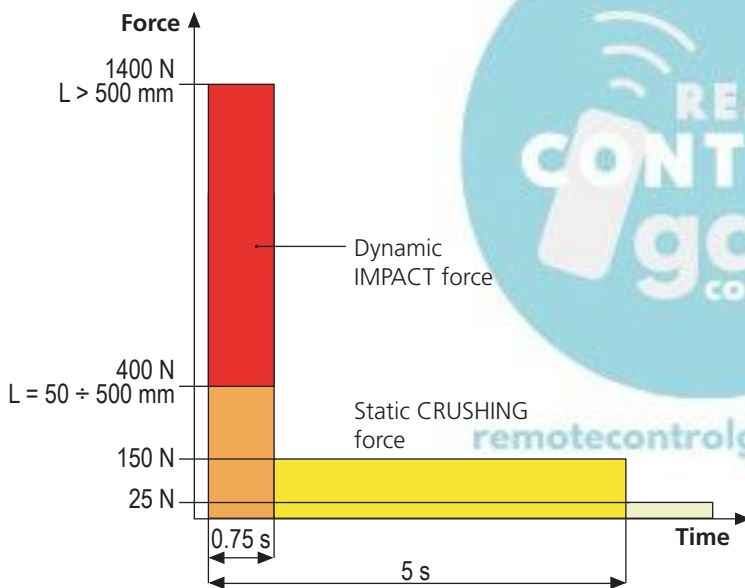

16 - MAINTENANCE

Maintenance should be performed in full compliance with the safety instructions described in this manual and in accordance with current legal and regulatory provisions. The recommended interval between each maintenance operation is six months, the checks involved should at least relate to:

- the perfect efficiency of all warning devices
- the perfect efficiency of all safety devices
- measurement of the gate operating forces
- the lubrication of mechanical parts on the automation device (where necessary)
- the state of wear of the mechanical parts on the automation device
- the state of wear of the electrical cables on the electromechanical actuators

The result of each check should be recorded in a gate maintenance log.



17 - DISPOSAL OF THE PRODUCT

As for the installation operations, even at the end of this product's life span, the dismantling operations must be carried out by qualified experts.

This product is made up of various types of materials: some can be recycled while others need to be disposed of. Find out about the recycling or disposal systems envisaged by your local regulations for this product category.

Important! – Parts of the product could contain pollutants or hazardous substances which, if released into the environment, could cause harmful effects to the environment itself as well as to human health. As indicated by the symbol opposite, throwing away this product as domestic waste is strictly forbidden. So dispose of it as differentiated waste, in accordance with your local regulations, or return the product to the retailer when you purchase a new equivalent product.

Important! – the local applicable regulations may envisage heavy sanctions in the event of illegal disposal of this product.

AUTOMATION DEVICE USERS MANUAL

AUTOMATION DEVICE USER INFORMATION

An automation system is a great convenience, in addition to a valid security system, and with just a little, simple care, it is made to last for years.

Even if your automation device meets all the safety standards, this does not exclude the presence of residual risk, i.e. the possibility that hazardous situations may be created, usually due to irresponsible or even improper use, and for this reason we wish to offer some advice regarding the behaviour to be adopted in order to avoid problems:

Prior to using the automation device for the first time, ask the installer to explain the sources of residual risk to you, and take some time to read the instruction manual and user information delivered by the installer. Keep the manual for any future doubts and give it to any new owners of the device.

Your automation device is a machine that faithfully follows your commands; irresponsible and improper use can make it become hazardous: do not start movement of the device if there are people, animals or objects within its radius of action.

Children: installed in accordance with technical regulations, an automation system guarantees a high level of safety. However, it is prudent to prevent children from playing near the automation device and to avoid unintentional use; never leave the remote control within the reach of children: it is not a toy!

Anomalies: as soon as the automation device shows any anomalous behaviour, remove the electricity supply and perform manual unblocking. Do not attempt any repairs yourself, but ask your installer: in the meantime, the system can operate as a non-automated device.

Maintenance: as with all machinery, your automation devices requires periodic maintenance so that it may continue to work for as long as possible, and in complete safety. Agree a periodic maintenance plan with your installer; V2 SpA recommends a maintenance plan to be performed every 6 months for normal domestic use, but this period may vary depending on the intensity of use. Any inspection, maintenance or repairs should only be performed by qualified personnel. Even if you think you know how, do not modify the system and the automation device programming and adjustment parameters: your installer is responsible for this. Final testing, periodic maintenance and any repairs should be documented by those performing the operations, and the documents held by the system owner.

Disposal: on completion of the device's operating life, ensure that disposal is performed by qualified personnel and that the materials are recycled or disposed of in accordance with valid local regulations.

Important: If your device is fitted with a radio control, the function of which appears to deteriorate over time, or has even ceased to function, this might simply depend on the batteries being run down (depending on the type, this may be from several months to up to two/three years). Before contacting your installer, try replacing the battery with the battery from another, working transmitter: if this was the cause of the problem, then simply replace the battery with another of the same type.

Are you satisfied? Should you wish to add another automation device to your home, contact the same installer and ask for a V2 SpA product: we guarantee you the most advanced products on the market and maximum compatibility with existing automation devices. Thank you for having read these recommendations, and for any present or future needs, we ask you to contact your installer in full confidence.

MOTOR OVERRIDING SYSTEM

In case of absence of current, the gate can be released by operating on the motor:

1. Open the hatch of the lock **J** in front of the motor
2. Insert the key **K** in the lock and turn clockwise to open the hatch of the release on the side
3. Insert the key **L** into the hole and turn clockwise until reached the limit switch
4. At this point you can manually move the gate

To restore the automation, proceed as follows:

1. Bring the gate to the fully closed position
2. turn the key **L** anticlockwise until reached the limit switch, then draw it out
3. turn the key **K** anticlockwise closing the hatch of the lock, then draw it out
4. Close the lock with the hatch **J**

