

INDEX

1 - 1 - GENERAL SAFETY INFORMATION	24
1.1 - PRELIMINARY CHECKS AND IDENTIFICATION OF THE TYPE TO BE USED	25
1.2 - TECHNICAL ASSISTANCE SERVICE	26
1.3 - EU DECLARATION OF CONFORMITY	26
2 - TECHNICAL DATA	26
3 - INSTALLATION OF THE MOTOR	27
3.1 - POSITIONING OF THE MOTOR	27
3.2 - MOUNTING THE RACK	28
3.3 - FIXING OF THE MOTOR	28
3.4 - INSTALLING THE LIMIT SWITCHES	29
3.5 - MOTOR OVERRIDING SYSTEM	29
3.6 - INSTALLATION LAYOUT	30
4 - CONTROL UNIT	31
5. 5. CONTROL UNIT SETTING	31
5.1 - TRIMMER ADJUSTMENT	31
5.2 - DIP-SWITCH ADJUSTMENT	31
6 - ELECTRICAL CONNECTIONS	32
6.1 - LINE POWER SUPPLY	33
6.2 - FLASHING LIGHT	33
6.3 - AUX CONTACT	33
6.4 - SAFETY DEVICES	33
6.5 - GATE OPEN PILOT LIGHT	33
6.6 - WIRED COMMANDS	33
6.7 - ANTENNA	33
7 - TRANSMITTER PROGRAMMING	34
7.1 - START BUTTON PROGRAMMING	34
7.2 - PROGRAMMING OF THE PEDESTRIAN START BUTTON	34
7.3 - TOTAL DELETION OF TRANSMITTERS IN MEMORY	34
7.4 - DELETION OF A SINGLE TRANSMITTER	34
7.5 - REMOTE TRANSMITTER PROGRAMMING	34
8 - PROGRAMMING THE GATE PATH	35
8.1 - BASIC PROGRAMMING OF THE AUTOMATION MOVEMENT	35
8.2 - PROGRAMMING OF THE WIDTH OF THE PEDESTRIAN OPENING	35
8.3 - ADVANCED PROGRAMMING OF THE AUTOMATION MOVEMENT	35
9. LED SIGNALLING	36
9.1 - INPUT STATUS SIGNALLING LEDES	36
9.2 - ERROR SIGNALLING LEDES	36
ADVANCED PROGRAMMING	37
10 - AUX OUTPUT PROGRAMMING	37
10.1 - PROGRAMMING OF THE BUTTON LINKED TO THE "AUX" OUTPUT	37
10.2 - SELECTION OF DEVICE CONNECTED TO "AUX" OUTPUT	37
10.3 - SELECTION OF "AUX" OUTPUT OPERATING MODE	38
11. SAFETY DEVICE ADVANCED PROGRAMMING SEQUENCES	38
11.1 - PHOTO-TEST ACTIVATION/DEACTIVATION	38
11.2 - SELECTION OF THE OUTPUTS LINKED TO THE PHOTO-TEST	39
11.3 - SELECTION OF THE TYPE OF DEVICES LINKED TO "PHO2"	39
12. SETTING THE WIRED COMMANDS	39
12.1 - SELECTING THE WIRED COMMAND MODES	39
12.2 - ACTIVATING/DEACTIVATING START AND PEDESTRIAN LOCK	40
13. OTHER FUNCTIONS	40
13.1 - ACTIVATING/DEACTIVATING THE CONTROL UNIT PROTECTION DEVICE	40
13.2 - RESETTING THE CONTROL UNIT'S DEFAULT PARAMETERS	40
14. F.A.Q	41
15 - TESTING AND START-UP	42
16 - MAINTENANCE	42
17 - DISPOSAL OF THE PRODUCT	42

AUTOMATION DEVICE INSTALLERS MANUAL

1 - GENERAL SAFETY INFORMATION

 **Prior to proceeding with installation, it is essential the instructions be read in full, since they contain important information regarding safety, installation, use and maintenance.**

AUTOMATION MUST BE IMPLEMENTED IN COMPLIANCE WITH THE EUROPEAN REGULATIONS IN FORCE:

EN 60204-1, EN 12445, EN 12453, EN 13241-1, EN 12635

- The installer must provide for a device (es. magnetothermal switch) ensuring the omnipolar sectioning of the equipment from the power supply. The standards require a separation of the contacts of at least 3 mm in each pole (EN 60335-1).
- The plastic case has an IP44 insulation; to connect flexible or rigid pipes, use pipefittings having the same insulation level.
- Installation requires mechanical and electrical skills, therefore it shall be carried out by qualified personnel only, who can issue the Compliance Certificate concerning the whole installation (Machine Directive 2006/42/CEE, Annex IIA).
- Also the automation upstream electric system shall comply with the laws and rules in force and be carried out workmanlike.
- We recommend to make use of an emergency button, to be installed by the automation (connected to the control unit STOP input) so that the gate may be immediately stopped in case of danger.
- For correct installation of the system, we recommend following the instructions issued by UNAC very carefully
- This instruction manual is only for qualified technicians, who specialize in installations and automations.
- The contents of this instruction manual do not concern the end user.
- Every programming and/or every maintenance service should be done only by qualified technicians.
- Anything not expressly described in these instructions is prohibited; unforeseen uses may be a source of danger to people and property.
- Do not install the product in explosive environments and atmospheres: the presence of inflammable gases or fumes is a serious safety hazard.
- Do not make any modifications to any part of the automation device, or the accessories connected to it, unless described in this manual.
- Any other modifications will void the warranty on the product.
- The installation steps should be conducted so as to avoid rainy weather, which can expose electronic circuits to dangerous water seepage.
- All operations requiring the casing of the device to be opened should be performed with the control unit disconnected from the electricity supply and with a warning notice displayed, for example: "CAUTION, MAINTENANCE IN PROGRESS".
- Avoid exposing the device close to sources of heat and flame.

- In the event of interventions on automatic or differential breakers or fuses, it is essential that faults be identified and resolved prior to resetting. In the case of faults that cannot be resolved using the information to be found in this manual, consult the V2 customer assistance service.
- V2 declines all responsibility for failure to comply with good construction practice standards in addition to structural deformation of the gate that might occur during use.
- V2 reserves the right to make modifications to the product without prior warning.
- Installation/maintenance personnel should wear individual protection devices (IPDs), such as overalls, safety helmets, boots and gloves.
- The ambient operating temperature should be that indicated in the technical characteristics table.
- The automation device should be shut down immediately in the event of any anomalous or hazardous situation; the fault or malfunction should be immediately reported to the person responsible.
- All safety and hazard warnings on the machinery and equipment should be complied with.
- Electromechanical actuators for gates are not intended to be used by people (including children) with diminished physical, sensory or mental capacity, or lacking in experience or knowledge, unless they are under supervision or have been instructed in use of the actuator by a person responsible for safety.

V2 has the right to modify the product without previous notice; it also declines any responsibility to damage or injury to people or things caused by improper use or wrong installation.



1.1 - PRELIMINARY CHECKS AND IDENTIFICATION OF THE TYPE TO BE USED

The automation device should not be used until installation, as specified in "Testing and start-up", has been performed. It should be remembered that the device does not compensate for defects caused by improper installation, or poor maintenance, thus, prior to proceeding with installation, ensure that the structure is suitable and meets current standards and, if necessary, perform any structural modifications aimed at the implementation of safety gaps and the protection or segregation of all crushing, shearing and transit zones, and verify that:

- The gate has no friction points, either during closing or opening.
- The gate must be equipped with mechanical stoppers.
- The gate is well balanced, i.e. there is no tendency to move spontaneously when stopped in any position.
- The position identified for fixing the motor reducer allows easy and safe manual manoeuvring, compatible with the size of the motor reducer itself.
- The support on which the automation device will be fixed is solid and durable.
- The mains power supply to which the automation device is connected has a dedicated safety earthing system and differential breaker with tripping current less than or equal to 30 mA (the breaker gap distance should be greater than or equal to 3 mm).

Warning: The minimum safety level depends on the type of use; please refer to the following outline:

TYPE OF ACTIVATION COMMANDS	CLOSURE USE TYPE		
	GROUP 1 Informed people (use in private area)	GROUP 2 Informed people (use in public area)	GROUP 3 Informed people (unlimited use)
Man-present command	A	B	Not possible
Remote control and closure in view (e.g. infrared)	C or E	C or E	C and D or E
Remote control and closure not in view (e.g. radio)	C or E	C and D or E	C and D or E
Automatic control (e.g. timed closure control)	C and D or E	C and D or E	C and D or E

GROUP 1 - Only a limited number of people are authorised for use, and closure is not in a public area. Examples of this type are gates inside business premises, where the sole users are employees, or a part of them who have been suitably informed.

GROUP 2 - Only a limited number of people are authorised for use, but in this case, closure is in a public area. An example of this may be a company gate that accesses onto a public street, and which is only used by employees.

GROUP 3 - Anyone can use the automated closure, which is thus located on public land. For example the access gate to a supermarket or an office, or a hospital.

PROTECTION A - Closure is activated by means of a control button with the person present, i.e. with maintained action.

PROTECTION B - With the person present, closure is activated by a command controlled by means of a key-switch or the like, in order to prevent use by unauthorised persons.

PROTECTION C - Restricts the force of the leaf of the door or gate. I.e., in the case of the gate striking an obstacle, the impact force must fall within a curve established by the regulations.

PROTECTION D - Devices, such as photocells, capable of detecting the presence of people or obstacles. They may be active on just one side or on both sides of the door or gate.

PROTECTION E - Sensitive devices, such as footboards or immaterial barriers, capable of detecting the presence of a person, and installed in such a way that the latter cannot be struck in any way by a moving leaf or panel. These devices should be active within the entire "danger zone" of the gate. The Machinery Directive defines "Danger Zone" as any zone surrounding and/or near machinery where the presence of an exposed person constitutes a risk to the health and safety of that person.

The risk analysis should take into consideration all danger zones for the automation device, which should be appropriately protected and marked.

In a clearly visible area, apply a sign with information identifying the motorised door or gate.

The installer should provide the user with all the information relating to automatic operation, emergency opening and maintenance of the motorised door or gate.



1.2 - TECHNICAL ASSISTANCE SERVICE

For any installation problem please contact our Customer Service at the number +39-0172.812411 operating Monday to Friday from 8:30 to 12:30 and from 14:00 to 18:00.

1.3 - EU DECLARATION OF CONFORMITY AND DECLARATION OF INCORPORATION OF PARTLY COMPLETED MACHINE

Declaration in accordance with Directives: 2014/35/UE (LVD); 2014/30/UE (EMC); 2006/42/CE (MD) ANNEX II, PART B

The manufacturer V2 S.p.A., headquarters in Corso Principi di Piemonte 65, 12035, Racconigi (CN), Italy

Under its sole responsibility hereby declares that:
the partly completed machinery model(s):
TORQ500A-230V
TORQ800A-230V

Description: electromechanical actuator for sliding gates

- is intended to be installed on sliding gates, to create a machine according to the provisions of the Directive 2006/42/EC. The machinery must not be put into service until the final machinery into which it has to be incorporated has been declared in conformity with the provisions of the Directive 2006/42/EC (annex II-A).

- is compliant with the applicable essential safety requirements of the following Directives:
Machinery Directive 2006/42/EC (annex I, chapter 1)
Low Voltage Directive 2014/35/EU
Electromagnetic Compatibility Directive 2014/30/EU
Directive ROHS-3 2015/863/EU

The relevant technical documentation is available at the national authorities' request after justifiable request to:
V2 S.p.A.
Corso Principi di Piemonte 65, 12035, Racconigi (CN), Italy

The person empowered to draw up the declaration and to provide the technical documentation:

Lauro Buoro
Legal representative of V2 S.p.A.
Racconigi, 01/11/2022



2 - TECHNICAL DATA

	TORQ500A-230V	TORQ800A-230V
Gate maximum weight	500 Kg	800 Kg
Power supply	230 VAC / 50 Hz	230 VAC / 50 Hz
Maximum power	300 W	400 W
Gate maximum speed	0,17 m/s	0,17 m/s
Maximum thrust	450 N	850 N
Duty cycle	30 %	30 %
Pinion	M4 - Z15	M4 - Z15
Operation temperature	-20 ÷ +55 °C	-20 ÷ +55 °C
Weight	10 Kg	12 Kg
Protection	IP44	IP44
Maximum load on 24 VAC attachments	250mA	250mA
Protection fuses	F1 = 5A / F2 = 1A	F1 = 5A / F2 = 1A

3 - INSTALLATION OF THE MOTOR

3.1 - POSITIONING OF THE MOTOR

To fix TORQ, follow the instructions below:

1. use the measurements indicated in the drawing for the foundations
2. Arrange for one or two pipes for the passage of electric cables
3. Assemble the 2 clamps on the anchoring plate and fix them with the 4 bolts issued with the motor
4. Pour the concrete and position the anchoring plate

⚠ WARNING: check that the plate be on a perfectly levelled surface and parallel to the gate

5. Wait for the complete setting of the concrete
6. Unscrew the bolts fixing the base to the clamps and put the motor on the plate
7. Insert the 4 grains with their nuts in the proper place. Adjust the 4 grains to make the motor be perfectly levelled
8. Control that the motor is perfectly parallel to the gate, then insert the 2 washers **R** and lightly screw the 2 bolts **D**

⚠ WARNING: put the washer **G** into the hole for the passing of the cables as shown in the picture. Pierce the washer to let the cable to be connected to the control unit pass, paying attention to the dimensions in order to avoid the entrance of insects and other small animals.

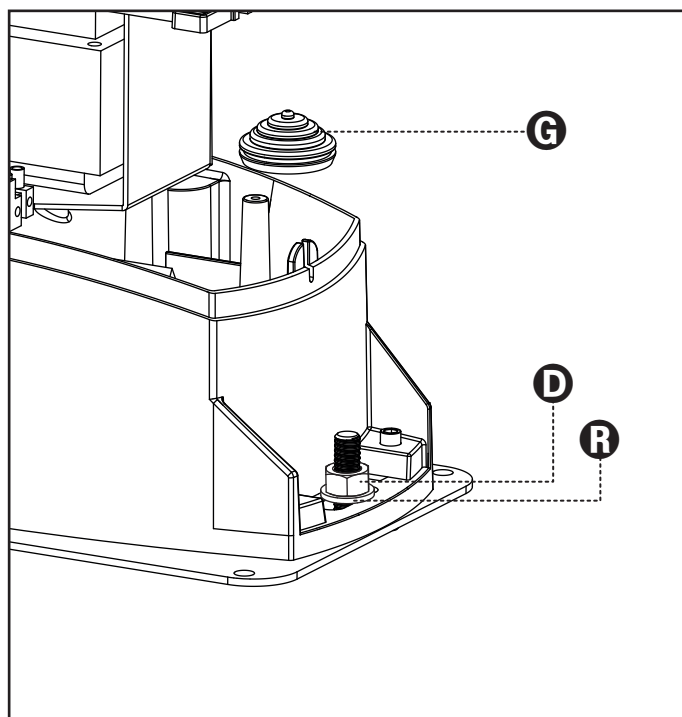
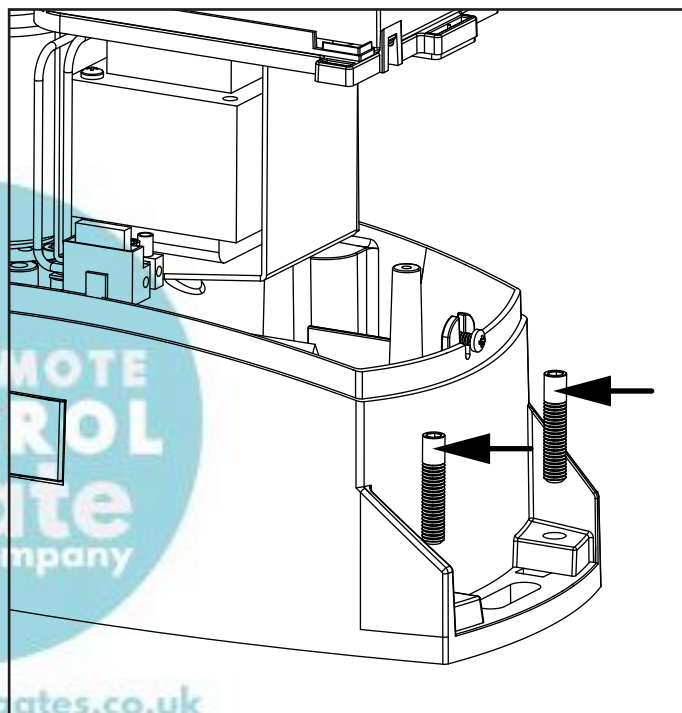
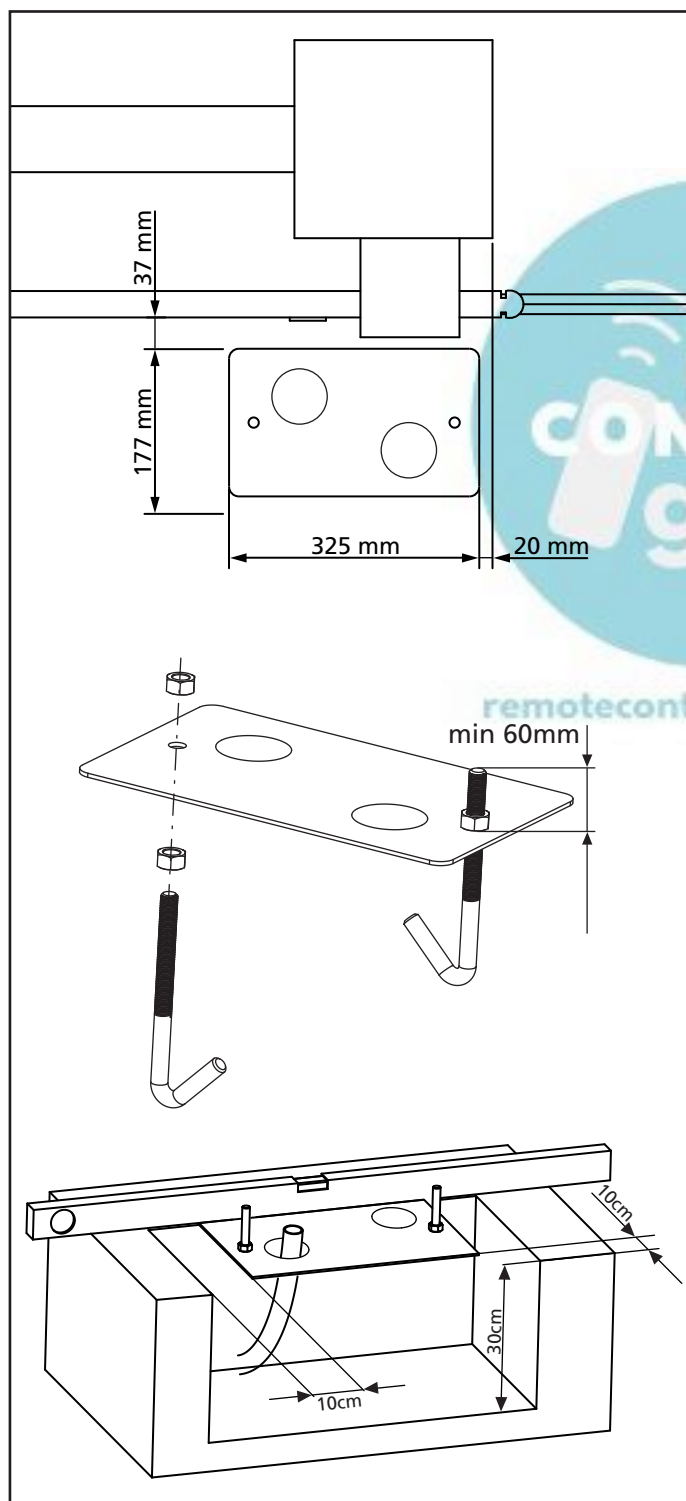

3.2 - MOUNTING THE RACK

1. Release the motor and turn the gate completely open.
2. Fix all the rack elements to the gate, making sure that they stand at the same height than the motor pinion.

The rack **MUST BE** positioned 1 or 2 mm over the pinion of the motor all the gate length.

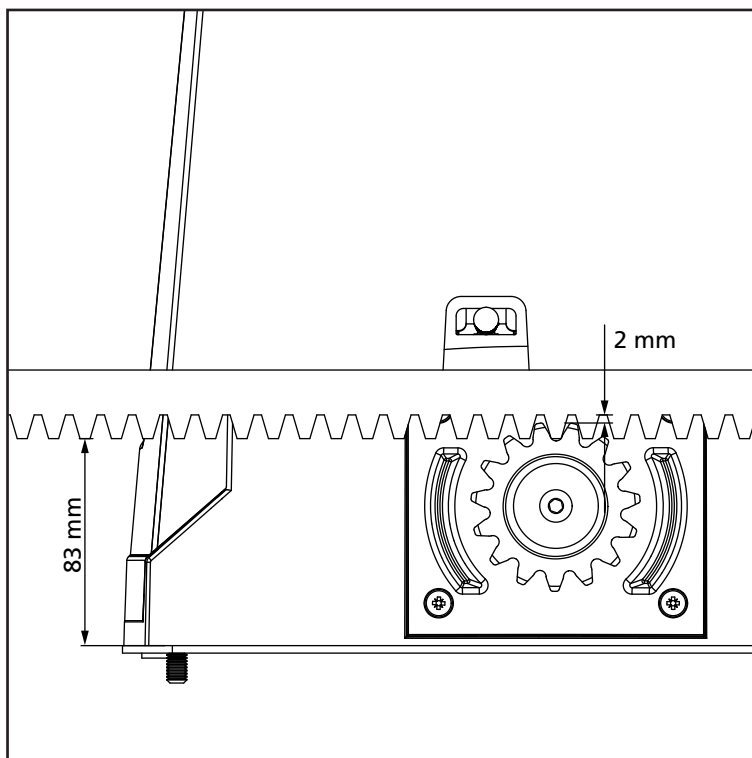

3.3 - FIXING OF THE MOTOR

Check the following points:

1. the motor must be on a levelled surface and perfectly parallel to the gate
2. the distance between pinion and rack must be 1 or 2 mm. If needed, adjust the 4 grains
3. the rack must be trued up with the pinion of the motor
4. the minimum distance between the maximum overall of the gate and the case of the pinion of the motor must be of at least 5 mm
5. Check the above indicated conditions and proceed fixing the 2 bolts **D** anchoring the motor to the plate.

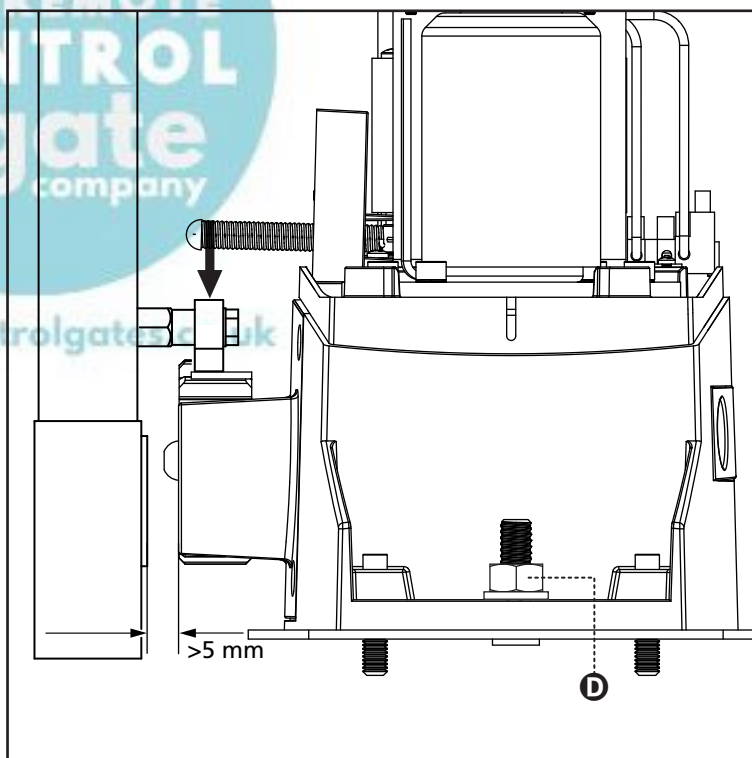

3.4 - INSTALLING THE LIMIT SWITCHES

⚠ WARNING: For your safety, it is necessary that the gate is equipped with mechanical stoppers. If the gate is not equipped with these stoppers, an erratic movement past the range limit may cause the gate to fall.

Move the door to open/close position. Fix the left and right stopstirrups on the rack with the screws provided, considering that when stopping, the gate slides for 2/3 cm more after the limit switch intervenes. Set the motor automatic functioning

⚠ WARNING: Once checked the proper working of the system, we suggest to weld the end-of-stroke brackets on the rack.

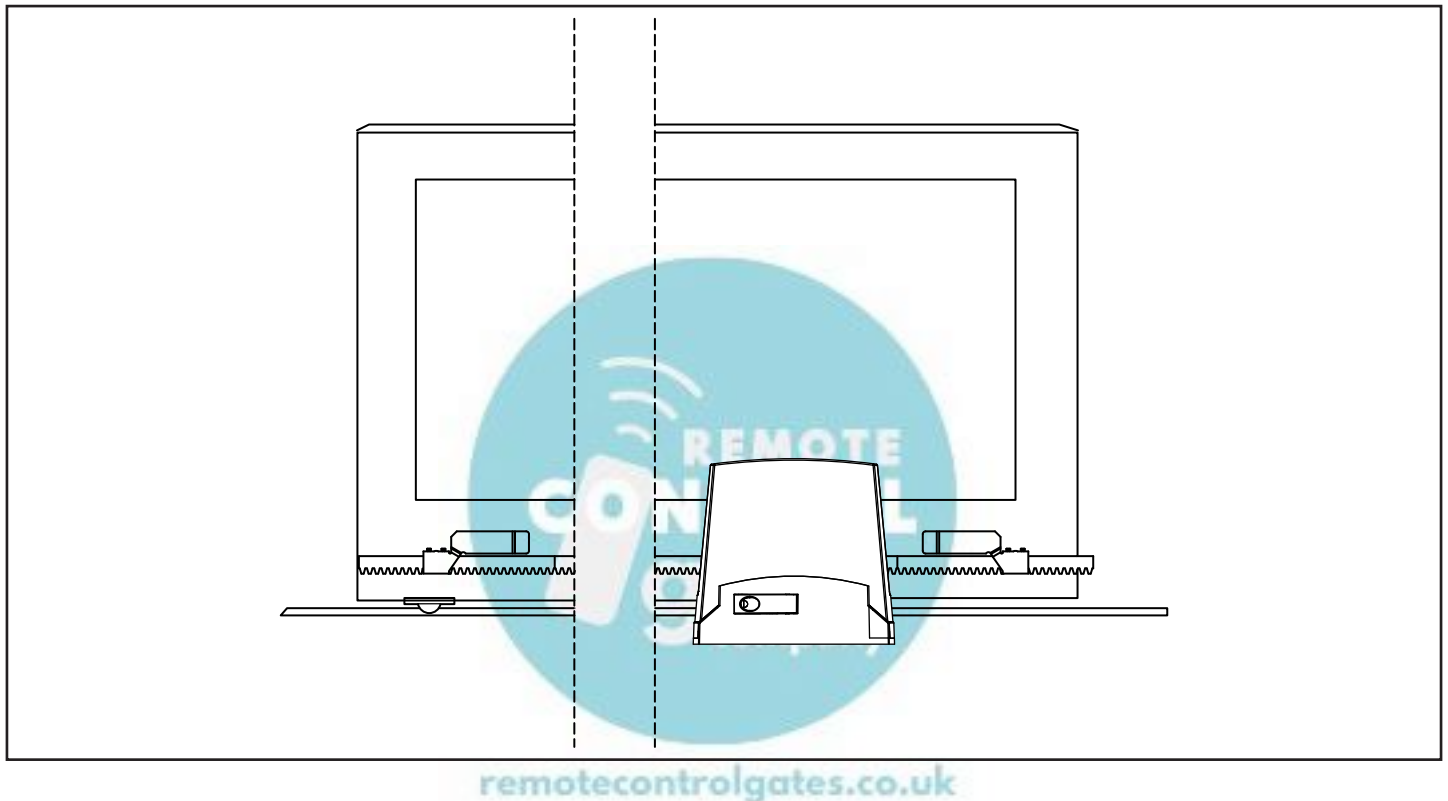

3.5 - MOTOR OVERRIDING SYSTEM

⚠ ATTENTION: before operating the manual release disconnect the power. The motor is anyway disconnected during the release, thanks to the presence of a safety micro-switch.

Manual control has been thought for manual opening of the gate in case of power-cut or motor breakdown.

1. Operate the manual release moving back the key hole cover.
2. Insert the key in the cylinder lock and turn it of 90° clockwise direction.
3. Pull the lever till it is perpendicular to the gear-motor.

Automation restore:

1. Bring back the lever in the original position.
2. Insert the key in the cylinder lock and turn it of 90° anticlockwise direction

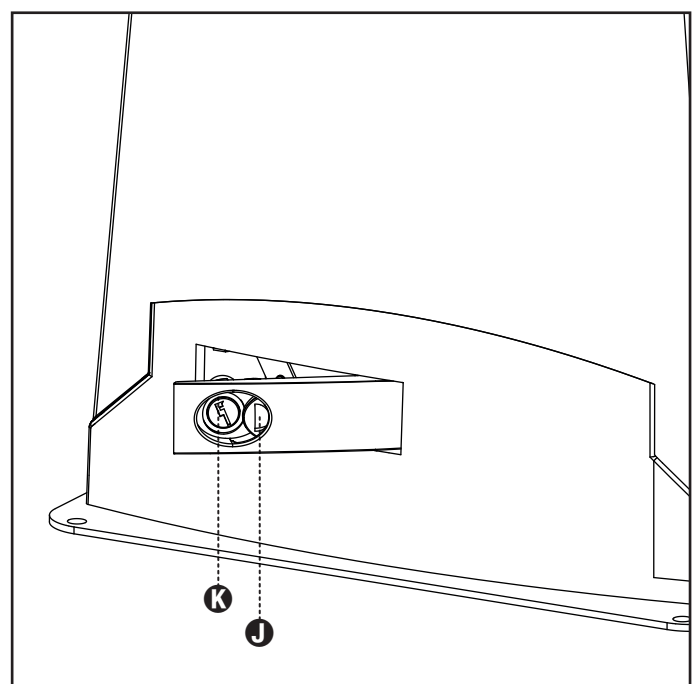

3.6 - INSTALLATION LAYOUT

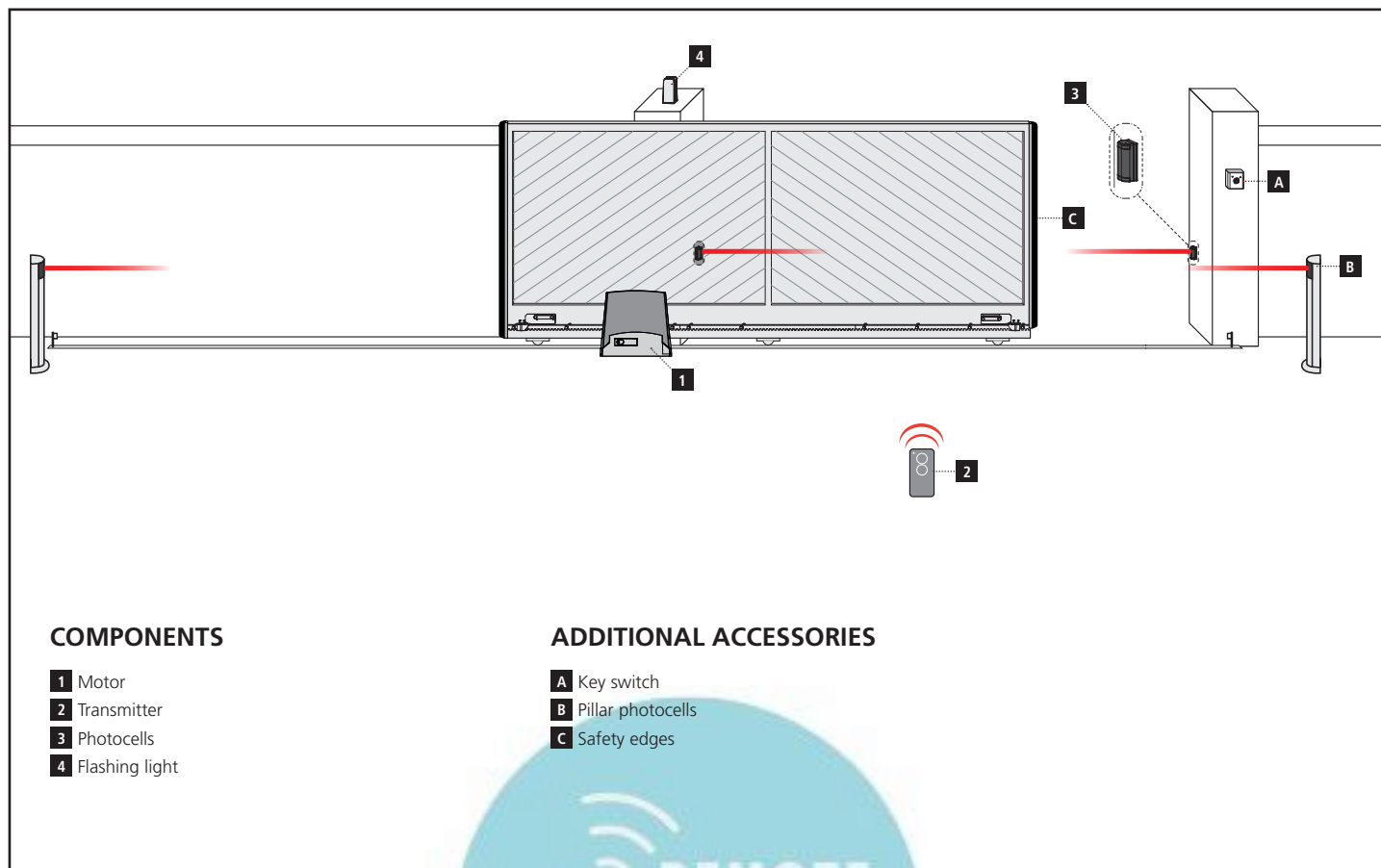

LENGTH OF THE CABLE	< 10 metres	from 10 to 20 metres	from 20 to 30 metres
Power supply 230V/120V	3G x 1,5 mm ²	3G x 1,5 mm ²	3G x 2,5 mm ²
Photocells (TX)	2 x 0,5 mm ²	2 x 0,5 mm ²	2 x 0,5 mm ²
Photocells (RX)	4 x 0,5 mm ²	4 x 0,5 mm ²	4 x 0,5 mm ²
Key switch	2 x 0,5 mm ²	2 x 0,5 mm ²	2 x 0,5 mm ²
Flashing light	2 x 1,5 mm ²	2 x 1,5 mm ²	2 x 1,5 mm ²
Antenna (integrated into the flashing light)	RG174	RG174	RG174

4 - CONTROL UNIT

- Flasher control with/without integrated intermittency function
- Integrated management for electric locks 12V max. 15VA or settable to 24V with dedicated programming. This output can also be used to control courtesy lights
- Inputs for start, stop and pedestrian opening wired commands, customisable to open, stop and close
- Double input for safety devices: "PHO1" during closing and "PHO2" during closing and/or opening
- Possibility of powering 24VDC accessories
- Input for gate status pilot light signalling the position of the leaves
- Input for external antenna that can be used for increasing the range of the transmitters
- Pause time for automatic re-closing adjustable to between 0 and 180 sec. with trimmer
- Obstacle sensitivity adjustment with trimmer
- Motor force adjustment with trimmer
- Incorporated radio receiver (433.92MHz), compatible with V2 rolling transmitters
- 6 signalling LEDs (Paragraph 7).
- Slow-speed opening and closing (customisable through dedicated programming).

5. CONTROL UNIT SETTING

5.1 - TRIMMER ADJUSTMENT

POWER: adjustment of motor power. Turning the trimmer clockwise increases the motor's power. To validate the modification it is necessary to programme the gate path.

OBS: Obstacle, sensitivity to obstacles: adjustment of the obstacle detection function. Turning the trimmer clockwise increases the drive time before obstacle detection (less sensitivity). Therefore, in systems with particularly unfavourable mechanical conditions, it is advisable to keep the drive time high.

PAUSE: Pause time before automatic gate closing. Turning the trimmer clockwise increases the pause time from 0 to 180 seconds. Please note: the AUTO dip-switch must be put to ON.

DELAY: NOT USED

 **Varying the "POWER" trimmer has no effect until the stroke is reprogrammed (par. 8).**

5.2 - DIP-SWITCH ADJUSTMENT

DIP		DESCRIPTION OF OPERATION
DIP 1-2 MOTOR	OFF ON	 do not change the DIP setting
	ON	Step-by-step command mode: Open / Stop / Close / Stop At every start pulse (wired or via transmitter), the control unit performs an action. Starts the motor if the automation system is stopped, and stops it if it is moving.
DIP 3 STEP	OFF	Condominium mode The control unit only accepts commands (either wired or via transmitter) for the opening phase. Starts again from zero with the set delay when the automation system is open. With the automation in the opening phase, it continues to open, and with the system in the closing phase it reopens fully. The automation can re-close with the time set through the "PAUSE" trimmer, if the "AUTO" dip-switch is set to ON. If not, it is necessary to give a START command (either wired or via transmitter) with the automation fully open.
	ON	Automatic closing activated (time set with the "Pause" trimmer)
DIP 4 AUTO	OFF	Automatic closing deactivated
	ON	Safety devices connected to "PHO2" set as photocells (movement stopped during opening and closing)
DIP 5 PHO2	OFF	Safety devices connected to "PHO2" set as edges (reverse of opening movement)
	ON	Intermittent power supply for the flashing light
DIP 6 HAZ	OFF	Fixed power supply for the flashing light
	ON	Immediate re-closing after intervention of "PHO1" photocells
DIP 7 FAST	OFF	No intervention of the photocells during re-closing
	ON	Reverse opening direction (the system must be programmed afterwards)
DIP 8 FUNC	OFF	Reverse opening direction (the system must be programmed afterwards)

6 - ELECTRICAL CONNECTIONS

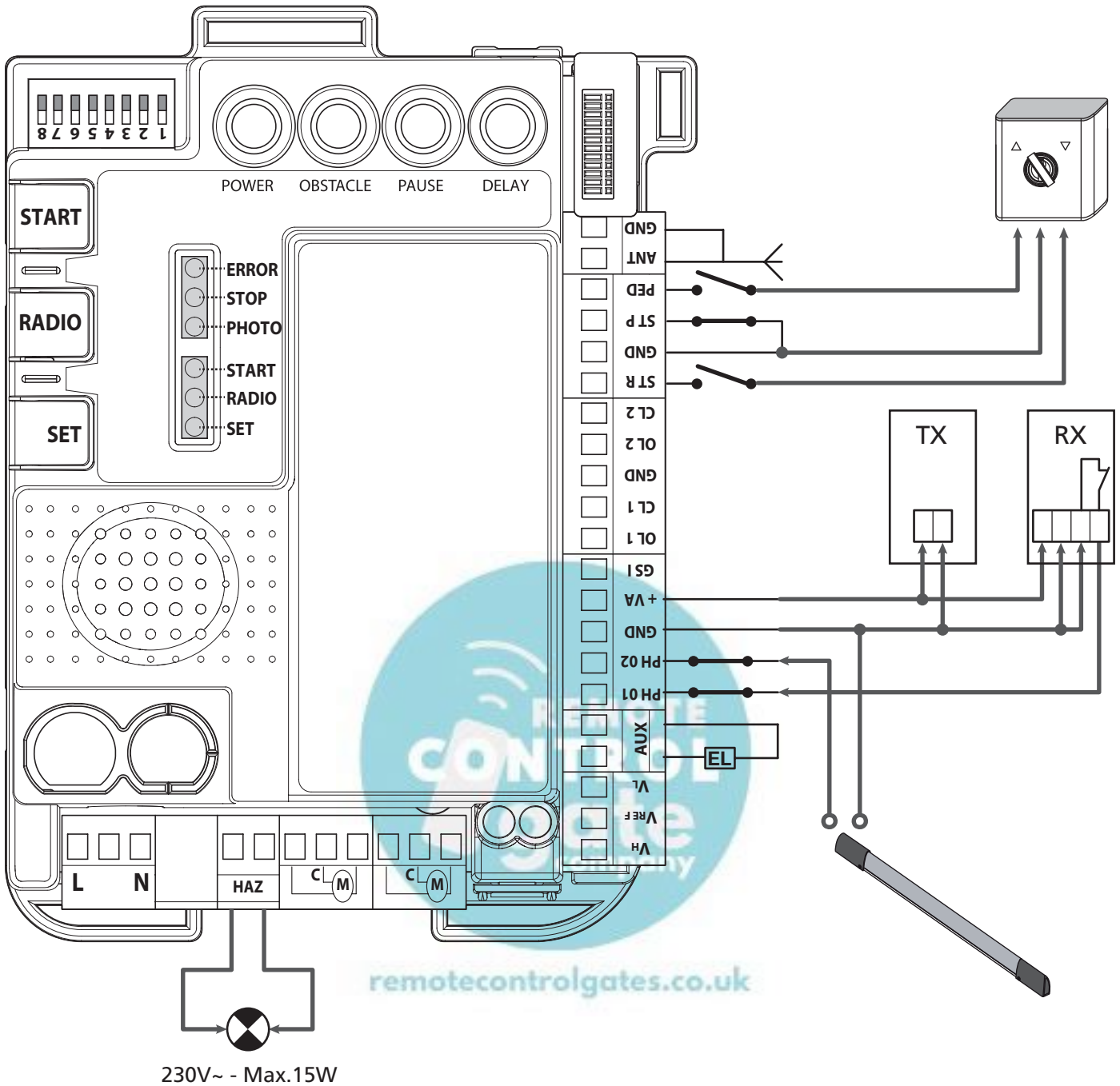

L	Power phase 230 VAC
N	Neutral 230 VAC
HAZ	Flashing light 230Vac max 15W
AUX	AUX contact / electric lock
PH 01	Photocell / safety edge. Normally closed contact
PH 02	Photocell / safety edge. Normally closed contact
GND	Common of the PH01 - PH02 terminals
+VA	Rated power 24Vdc
GSI	Positive gate PILOT LIGHT (24Vdc, max3W)

OL 1	Opening limit switch
CL 1	Closing limit switch
ST R	START: normally open contact
GND	Common of the STR - STP - PED terminals
ST P	STOP: normally closed contact
PED	PEDESTRIAN START: normally open contact
ANT	Antenna shield
GND	Antenna

6.1 - LINE POWER SUPPLY

The "L" and "N" inputs are prearranged for the line voltage connection. This must be 230Vac 50Hz.

6.2 - FLASHING LIGHT

The connected lamps must have 230V with 15W maximum power. Thanks to the "HAZ" dip-switch 6 (see Paragraph 3.1), the control unit can supply oscillating or continuous voltage based on the warning light connected (with or without integrated oscillating circuit)

6.3 - AUX CONTACT

By default, the AUX contact is able to control an electric lock (customisable as courtesy light) with 12V, by giving a 2-second pulse for every movement command received from the control unit. However, this output can be customised with the advanced programming functions mentioned in Paragraph 10.

6.4 - SAFETY DEVICES

 **To ensure correct operation of the accessories, eliminate the standard supplied connection.**

 **If multiple devices are connected on this contact, they must be series connected. If one or more photocell pairs are connected, the receivers must be alternated.**

"PHO1" CLOSING PHASE SAFETY DEVICES

It is possible to connect devices (e.g. photocells or edges with microswitches) with normally closed (NC) contact to the "PHO1" input.

These devices intervene during the gate's closing phase:

- during the closing phase they invert the movement direction and re-open the gate fully;
- during the opening phase they have no effect;
- with the gate closed they do not intervene;
- with the gate open they lock the closing commands.

"PHO2" OPENING OR OPENING/CLOSING PHASE SAFETY DEVICES

It is possible to connect devices (e.g. photocells or edges) with normally closed (NC) contact to the "PHO2" input.

These devices are actuated while the gate is moving, according to the setting of DIP5.

DIP5 = ON (functioning as photocells):

- in closing phase they invert the movement as soon as the device has been cleared
- in opening phase they continue the movement as soon the device has been cleared
- if the access is closed they inhibit the opening commands.
- if the access is open they inhibit the closing commands.

DIP5 = OFF (functioning as opening edge):

- during the closing phase they have no effect
- during the opening phase they re-close the gate fully
- with the gate closed they lock the opening commands.
- with the gate open they have no effect.

6.5 - GATE OPEN PILOT LIGHT

If the photo-test which is deactivated by default (see Paragraph 11.1) is not used, it is possible to connect a gate status pilot light to the "GSI" input. This light will signal the gate's position, specifically:

- gate closed: light off
- gate open: light turned on in fixed mode
- gate opening: light flashes
- gate closing: light flashes fast

 **The led must be powered with 24VDC, max 3W.**

6.6 - WIRED COMMANDS

The inputs for the start, stop and pedestrian opening wired commands can be customised to open, stop and close (Paragraph 12.1).

Moreover, they can be locked to prevent tampering with the system (Paragraph 12.2).

START CONTACT

The "START" input can be used to connect normally open clean contacts (present, for example, in selectors or buttons) for executing commands that pilot the automation, and settable through dip-switch 3.

 **COMPANY FUNCTION: if, with the automation closed, the START contact is pressed and held closed (for example, through a timer-controlled or bistable relay), the control unit opens the gate and the automation does not accept closing commands (neither automatic nor wired) until the contact is reopened.**

In this mode, dip-switch 3 STEP is normally put to OFF and dip-switch 4 AUTO to ON, to ensure that the gate never stops during the opening phase.

 **If multiple START contacts are connected, connect the contacts in parallel.**

PEDESTRIAN START CONTACT

The pedestrian function consists of a partial opening.

To customise the opening width, the pedestrian programming sequence must be carried out (see Paragraph 8.2).

This opening can be controlled via radio, by programming the transmitter (see Paragraph 7.2), and/or via wire by connecting the latter to the "PED" input of the normally open contacts (present, for example, in selectors and buttons).

STOP CONTACT

The "STOP" input can be used for connecting normally closed contacts (normally present in buttons), to immediately lock all the system's movements.

To restore the normal operating mode, the stop contact must be re-closed.

6.7 - ANTENNA

The antenna is used for enhancing the reception of signals of the radio transmitters. The control unit has, by default, a wire that functions as an antenna already connected to the PCB.

An external antenna can be connected to terminals 1 and 2 of the control unit.

 **If an external antenna is connected, the series connected wire must be disconnected.**

7 - TRANSMITTER PROGRAMMING

⚠ If, at the start of the following procedures, the "set", "radio" and "start" LEDs flash, it means that the programming protections have been activated – see Paragraph 13.1.

⚠ To interrupt the following programming procedures at any time, press the SET and RADIO buttons simultaneously or wait 10 seconds.

7.1 - START BUTTON PROGRAMMING

1. Press the RADIO button for 1 second: The red "radio" LED lights up steadily
2. Press the desired button of all the transmitters to be programmed: the red "radio" LED flashes
3. Press the SET and RADIO buttons simultaneously or wait 10 seconds to exit the procedure

7.2 - PROGRAMMING OF THE PEDESTRIAN START BUTTON

1. Press the RADIO button for 1 second: the red "radio" LED lights up steadily
2. Press the START button for 1 second: the red "radio" LED remains lit and the green "start" LED lights up steadily
3. Press the desired button of all the transmitters that you want to program: the red "radio" LED flashes and the green "start" LED stays on steady
4. Press the SET and RADIO buttons simultaneously or wait 10 seconds to exit the procedure

7.3 - TOTAL DELETION OF TRANSMITTERS IN MEMORY

1. Press the RADIO button for 4 seconds: the red "radio" LED flashes
2. Press the RADIO button for 1 second: the red "radio" LED flashes quickly
3. Erasing the memory performed: the red "radio" LED turns off

7.4 - DELETION OF A SINGLE TRANSMITTER

1. Press the RADIO button for 4 seconds: the red "radio" LED flashes
2. Press the SET button for 1 second: the red "radio" LED flashes and the yellow "set" LED lights up steadily
3. Press a button on the transmitter to be deleted: the red "radio" LED flashes and the yellow "set" LED flashes
4. Press the SET and RADIO buttons simultaneously or wait 10 seconds to exit the procedure

7.5 - REMOTE TRANSMITTER PROGRAMMING

1. Press key 1 and key 2 of a transmitter programmed for 4 seconds simultaneously
2. Press button 1 and button 2 of the transmitter you want to program simultaneously for 4 seconds

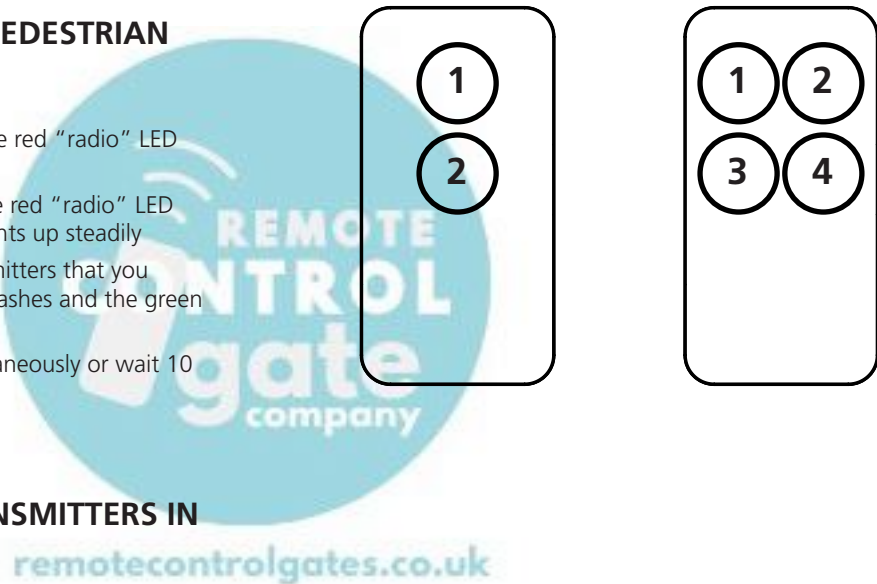

8 - PROGRAMMING THE GATE PATH

To start the system up, one of the following programming procedures must be carried out:

- basic programming of the automation's movement: self-learning of the manoeuvre times and of the slowdown start points.
- advanced programming of the automation's movement: self-learning of the manoeuvre times and manual setting of the slowdown start points.

The procedure for programming the partial opening is used to modify the default opening value.

⚠ If, at the start of the following procedures, the "set", "radio" and "start" LEDs flash, it means that the programming protection has been activated – see Paragraph 13.1.

⚠ To interrupt the following programming sequences at any time, press the SET and RADIO buttons simultaneously or wait 10 seconds.

8.1 - BASIC PROGRAMMING OF THE AUTOMATION MOVEMENT

1. Position the door in an intermediate position
2. Press the SET button for 3 seconds until the yellow "set" LED lights up steadily
3. The control unit performs a partial opening

⚠ WARNING! If the automation starts the movement with the closing instead of the opening it is necessary:

- **exit programming by pressing SET and RADIO simultaneously**
 - **move DIP8, see paragraph 5.2**
 - **redo the run schedule starting from point 1**
5. The control unit performs a total closure
 6. The control unit performs a total opening
 7. The control unit performs a total closure
 8. End of programming: the LEDs return to the normal operating configuration

8.2 - PROGRAMMING OF THE WIDTH OF THE PEDESTRIAN OPENING

⚠ Prior to proceeding with this programming procedure, first verify whether either the "basic automation movement programming" or the "advanced programming" have been completed.

1. Position the door in the fully closed position
2. Press the SET button for 2 seconds: the yellow "set" LED flashes
3. Press the START button for 1 second: the yellow "set" LED lights up steadily
4. Press the START button or a key of a programmed transmitter or a wired command
5. The control unit starts opening the door
6. When the gate reaches the position for pedestrian opening, press the START button or a key of a programmed transmitter: the control unit performs the stop and performs the total closing of the leaf, the yellow "set" LED goes off.
7. End of programming: the LEDs return to the normal operating configuration

8.3 - ADVANCED PROGRAMMING OF THE AUTOMATION MOVEMENT

1. Position the door in an intermediate position
2. Press the SET button for 1 second: the yellow "set" LED flashes
3. Press the RADIO button for 1 second: the yellow "set" LED lights up steadily
4. The control unit performs a partial opening: the yellow "set" LED flashes
5. The control unit waits for a possible change in the direction of movement for 8 seconds (dip 8). Press the SET button to proceed
6. The control unit performs a total closure: the yellow "set" LED remains on steady
7. Press the SET button or a programmed transmitter key
8. The control unit performs the opening
9. If slowing down is desired during opening, during the movement press the SET button or a transmitter button programmed to set the slowdown start point. otherwise, wait for the movement to complete
10. The control unit completes the opening
11. Press the SET button or a programmed transmitter key
12. The control unit performs a total closure
13. If slowing down is desired during closing, during the movement press the SET button or a transmitter button programmed to set the slowdown start point. Otherwise, wait for the movement to complete
14. The control unit completes closing: the yellow "set" LED turns off
15. End of programming: the LEDs return to the normal operating configuration

9. LED SIGNALLING

With the control unit powered up (if control unit protection is not activated) the yellow Set led flashes for 5 seconds and, if everything is correctly hooked up, the red "Photo" and "Stop" leds turn on to indicate that the two safety contacts are closed. The yellow Set LED is exclusively reserved for programming.

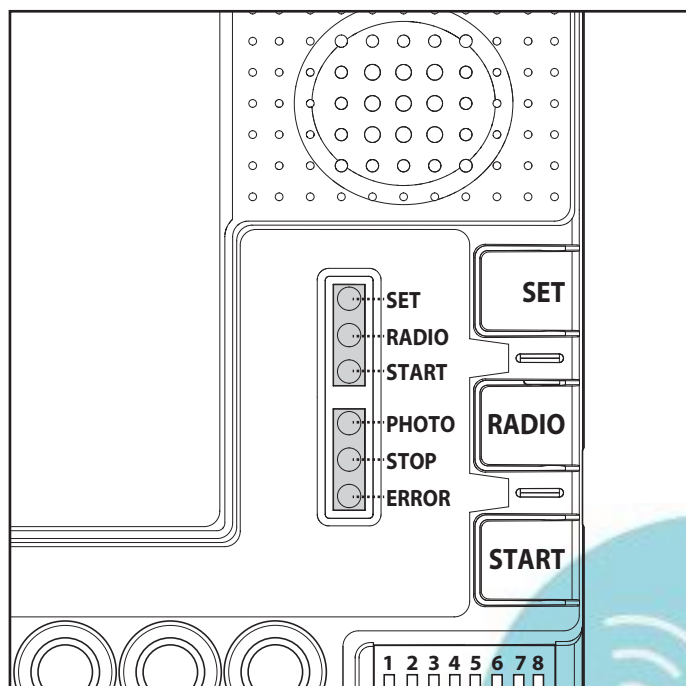

9.1 - INPUT STATUS SIGNALLING LEDES

The following signals refer to the control unit in standby mode, that is, powered and inactive for 12 seconds (not during programming).

GREEN PHOTO LED:

- ON in the fixed mode if the PHO1 and PHO2 contacts are closed
- OFF if at least one of the PHO1 or PHO2 contacts is opened

GREEN STOP LED:

- on in the fixed mode if the STOP contact is closed
- off if the STOP contact is open

GREEN START LED:

- on in the fixed mode if the START contact (terminals 15-16) is closed
- off if the START contact (terminals 15-16) is open

RED RADIO LED:

- flashes when a command is received through King Gates transmitter
- is off when the control unit is in standby mode

9.2 - ERROR SIGNALLING LEDES

RED "ERROR" LED:

The red "error" LED signals any errors that hamper the correct operation of the PCB.

With the control unit in standby mode, the error type is signalled with a series of flashes at regular intervals (1-second pause between two successive series) according to the following scheme:

1 flash: On-board memory damaged

2 flashes: Photo-test of safety devices failed.
See Paragraph 11.1 for solving the problem.

3 flashes: Path programming requested.
See Paragraph 8

4 flashes: Input "PHO2" set as a resistive edge and check failed.
See Paragraph 11.3 for solving the problem

GREEN START LED:

If, when START on the board is pressed or a control signal is sent by wire, the green led flashes three times without the system executing the manoeuvre, then "wire controls blocked" is enabled: see par. 12.2.

GREEN START LED, RED RADIO LED AND YELLOW SET LED:

If, when attempting to enter into any programming scheme, the set, radio and start LEDs flash fast three times, it means that the "control unit protection" is active.
See Paragraph 13.1 for solving the problem.

ADVANCED PROGRAMMING

The control unit has advanced programming that is not needed for commissioning the system but is useful for configuring advanced system operations.

10 - AUX OUTPUT PROGRAMMING

AUX USED AS COURTESY LIGHT

If the AUX output is used as courtesy light for controlling the lamps, a relay must be connected.

The light can be activated through a dedicated transmitter button (to be programmed as indicated in Paragraph 10.1) or associated with the wired or transmitter start button.

ACTIVATION OF THE LIGHT THROUGH A DEDICATED TRANSMITTER BUTTON AND TIMER-BASED SWITCHING OFF:

- connect a timer relay and set the desired switch-on time for the light;
- set the AUX output on courtesy light (see Paragraph 10.2);
- set the monostable work mode (see Paragraph 10.3);
- programme the desired transmitter button for the light command (see Paragraph 10.1).

The light will switch on with the programmed transmitter and switch off after the time set on the relay elapses.

SWITCHING ON/OFF OF THE LIGHT THROUGH A DEDICATED TRANSMITTER BUTTON:

- connect a monostable relay;
- set the AUX output on courtesy light (see Paragraph 10.2);
- set the bistable work mode, ON/OFF (see Paragraph 10.3);
- programme the desired transmitter button for the light command (see Paragraph 10.1).

The light switches on/off whenever the programmed transmitter is pressed.

ACTIVATION OF THE COURTESY LIGHT LINKED TO THE WIRED OR TRANSMITTER START BUTTON:

- connect a timer relay and set the desired switch-on time for the light;
- set the AUX output as electric lock (see Paragraph 10.2);
- set the work mode as electric lock (see Paragraph 10.3);
- if desired, programme the transmitter button for the START command (see Paragraph 7.1).

At every wired or transmitter start command, the light will switch on for the set time.

10.1 - PROGRAMMING OF THE BUTTON LINKED TO THE "AUX" OUTPUT

This procedure allows for programming the button of the radio control linked to the "AUX" output.

To use this function, the AUX output must be set to courtesy light - see Paragraph 10.2.

1. Press the RADIO button for 1 second: the red "radio" LED lights up steadily
2. Press the SET button for 1 second: the yellow "set" LED lights up steadily
3. Press the desired button for all the transmitters you want to program: the red "radio" LED flashes and the yellow "set" LED stays on steady
4. Press the SET and RADIO buttons simultaneously or wait 10 seconds to exit the procedure: the red "radio" LED and the yellow "set" LED go off

 **If, at the start of this procedure, the "set", "radio" and "start" LEDs flash, it means that the programming protection has been activated – see Paragraph 13.1.**

10.2 - SELECTION OF DEVICE CONNECTED TO "AUX" OUTPUT

Default = electric lock

This procedure allows for setting the "AUX" output for the operation as:

ELECTRIC LOCK: the control unit closes the AUX contact whenever a command is received.

By default the contact is closed for 2 seconds (electric lock mode). To change the work mode, see Paragraph 10.3.

COURTESY LIGHT: the control unit closes the AUX contact whenever a radio command is received (the AUX button must be programmed - see Paragraph 10.1). By default the command is monostable. To change the work mode, see Paragraph 10.3.

 **To control the AUX output when it has been set as a courtesy light output, you need to register a transmitter by following the procedure in paragraph 10.1 and connect a suitable relay.**

1. Press the SET, RADIO and START buttons simultaneously for 3 seconds, all the LEDs go out
2. Press the RADIO button for 1 second:
 - If the green "photo" LED is on AUX = Electric lock (if it is the correct setting go to point 5 if not proceed with point 3)
 - If the green "photo" LED is off AUX = Courtesy light (if it is the correct setting go to point 5 if not, proceed to point 4)
3. Press the SET button for 1 second: the red "radio" LED remains lit and the green "photo" LED turns off. Go to step 5
4. Press the SET button for 1 second: the red "radio" LED remains lit and the green "photo" LED lights up
5. Press the SET and RADIO buttons simultaneously or wait 10 seconds to exit the procedure: the LEDs return to the normal operating configuration

10.3 - SELECTION OF "AUX" OUTPUT OPERATING MODE

IF THE "AUX" OUTPUT IS SET AS LOCK the work mode can be set as:

ELECTRIC LOCK (default): at every command, the control unit closes the contact for 2 seconds

MAGNETIC LOCK: the control unit closes the contact only when the automation is fully closed

1. Press the SET, RADIO and START buttons simultaneously for 3 seconds, all the LEDs go out
2. Press the RADIO button for 1 second:
 - If the green "stop" LED is on AUX = Electric lock (if it is the correct setting go to point 5 if not proceed with point 3)
 - If the green "stop" LED is off AUX = Magnetic lock (if it is the correct setting go to point 5 if not, proceed to point 4)
3. Press the RADIO button for 1 second: the red "radio" LED remains lit and the green "stop" LED goes off. Go to step 5
4. Press the RADIO button for 1 second: the red "radio" LED remains lit and the green "stop" LED lights up
5. Press the SET and RADIO buttons simultaneously or wait 10 seconds to exit the procedure: the LEDs return to the normal operating configuration

IF THE "AUX" OUTPUT IS SET AS COURTESY LIGHT it is possible to set the working mode of the AUX contact when receiving a transmitter such as:

MONOSTABLE (default): after every radio command, the control unit closes the contact for 3 seconds.

BISTABLE, ON/OFF: after every radio command, the control unit changes the status from open to closed.

1. Press the SET, RADIO and START buttons simultaneously for 3 seconds, all the LEDs go out
2. Press the RADIO button for 1 second:
 - If the red "error" LED is lit AUX voltage = 12Vdc (if it is the correct setting go to point 5 if not proceed with point 3)
 - If the red "error" LED is off AUX voltage = 24Vdc (if it is the correct setting go to point 5 otherwise go to point 4)
3. Press the START button for 1 second: the red "radio" LED remains lit and the red "error" LED goes out. Go to step 5
4. Press the START button for 1 second: the red "radio" LED remains lit and the red "error" LED lights up
5. Press the SET and RADIO buttons simultaneously or wait 10 seconds to exit the procedure: the LEDs return to the normal operating configuration

11. SAFETY DEVICE ADVANCED PROGRAMMING SEQUENCES

These programming sequences are not essential to the system's operation, but they allow for controlling the safety devices by activating the photo-test when photocells are installed or controlling the resistance when 8.2kOhm resistive edges are mounted.

11.1 - PHOTO-TEST ACTIVATION/DEACTIVATION

Default = deactivated

The photo-test is a check aimed at verifying whether the 24VDC-powered photocells function properly.

It consists in cutting off the power supply to the transmitter photocell (TX) from the control unit, while subsequently verifying that the contact (PHO1, or PHO1 and PHO2, depending on the settings in Paragraph 11.2) opens. Subsequently, the control unit restores the power supply to the transmitter photocell and verifies that the contact closes.

This occurs before each movement of the automation.

For the test to work, the photocells must be wired according to the following scheme:

+24V RX photocell = terminal 8

+24V TX photocell = terminal 9

1. Press the SET, RADIO and START buttons simultaneously for 3 seconds, all the LEDs go out
2. Press the START button for 1 second:
 - If the green "photo" LED is on fototest = activated (if it is the correct setting go to point 5 if not proceed with point 3)
 - If the green "photo" LED is off, fototest = disabled (if it is the correct setting go to point 5 otherwise go to point 4)
3. Press the SET button for 1 second: the green "start" LED remains lit and the green "photo" LED turns off. Go to step 5
4. Press the SET button for 1 second: the green "start" LED remains lit and the green "photo" LED lights up
5. Press the SET and RADIO buttons simultaneously or wait 10 seconds to exit the procedure: the LEDs return to the normal operating configuration



The photo-test can only work with photocells powered at 24VDC.



By default the phototest function works on both contacts "PHO1" and "PHO2". To set this test only on the contact "PHO1", please see paragraph 11.2.



By enabling the photocells test, you will lose the "gate status indicator" function (GSI).



If "PHO2" is set as safety edge (DIP 5 OFF) the phototest will only be active on contact "PHO1".

11.2 - SELECTION OF THE OUTPUTS LINKED TO THE PHOTO-TEST

Default = PHO1 and PHO2 contacts

With this procedure, it is possible to decide on which safety devices to carry out the photo-test.

1. Press the SET, RADIO and START buttons simultaneously for 3 seconds, all the LEDs go out
2. Press the START button for 1 second:
 - If the green "stop" LED is on fototest = on contacts "PHO1" and "PHO2" (if it is the correct setting go to point 5 if not, proceed to point 3)
 - If the green "stop" LED is off, fototest = on the "PHO1" contact (if it is the correct setting go to point 5 if not, proceed to point 4)
3. Press the RADIO button for 1 second: the green "start" LED remains lit and the green "stop" LED goes off. Go to step 5
4. Press the RADIO button for 1 second: the green "start" LED remains lit and the green "stop" LED lights up
5. Press the SET and RADIO buttons simultaneously or wait 10 seconds to exit the procedure: the LEDs return to the normal operating configuration

 **The photo-test can only work with photocells powered at 24VDC.**

11.3 - SELECTION OF THE TYPE OF DEVICES LINKED TO "PHO2"

Default = "PHO2" set for devices with normally closed contact.

This procedure allows for setting the "PHO2" output for managing 8.2kOhm resistive edges. The control unit constantly verifies the integrity of the edge by measuring the resistance between the two dedicated terminals.

1. Press the SET, RADIO and START buttons simultaneously for 3 seconds, all the LEDs go out
2. Press the START button for 1 second:
 - If the red "error" LED is lit "PHO2" = resistive edge (if it is the correct setting go to point 5 if not proceed with point 3)
 - If the red "error" LED is off "PHO2" = device with NC normally closed contact (if it is the correct setting go to point 5 if not, proceed to point 4)
3. Press the START button for 1 second: the green "start" LED remains lit and the red "error" LED goes out. Go to step 5
4. Press the START button for 1 second: the green "start" LED remains lit and the red "error" LED lights up
5. Press the SET and RADIO buttons simultaneously or wait 10 seconds to exit the procedure: the LEDs return to the normal operating configuration

 **In order to carry out the check on the safety devices, the connected edges must be of the resistive type with 8.2 kOhm.**

12. SETTING THE WIRED COMMANDS

These programming sequences allow for locking wired commands, for managing the system solely with radio transmitters or for changing the operation of the wired commands to start and pedestrian.

 **If, at the start of the following procedures, the "set", "radio" and "start" LEDs flash, it means that the programming protection has been activated – see Paragraph 13.1.**

 **PTo interrupt the following programming sequences at any time, press the SET and RADIO buttons simultaneously or wait 10 seconds.**

12.1 - SELECTING THE WIRED COMMAND MODES

Default = "START" contact linked to the "STEP" dip-switch and "PED" partial opening contact.

This programming sequence allows for linking the "START" and "PED" contacts to the following operating modes:

- Open always/close always mode: the "START" contact always opens the automation, the "PED" contact always closes the automation
- Start/ped mode: "START" contact settable with "STEP" dip-switch, "PED" contact opens the automation partially.

1. Press the SET, RADIO and START buttons simultaneously for 3 seconds, all the LEDs go out
2. Press the SET button for 1 second:
 - If the green "stop" LED is on: mode always open / close always (if it is the correct setting go to point 5 if not, proceed to point 3)
 - If the green "stop" LED is off: start / ped mode (if it is the correct setting go to point 5 otherwise go to point 4)
3. Press the RADIO button for 1 second, the yellow "set" LED remains on and the green "stop" LED goes off. Go to step 5
4. Press the RADIO button for 1 second: the yellow "set" LED remains lit and the green "stop" LED lights up
5. Press the SET and RADIO buttons simultaneously or wait 10 seconds to exit the procedure: the LEDs return to the normal operating configuration

 **For controlling the automation also via radio with separate open/close commands, an external radio receiver must be installed.**

 **If you enable the mode "open / close", the dip STEP will affect only the radio commands.**

12.2 - ACTIVATING/DEACTIVATING START AND PEDESTRIAN LOCK

Default = wired start and start button on PCB activated.

This programming sequence allows for locking the "start" / "ped" wired input and the start button on the control unit. This may be useful for controlling the automation exclusively via radio.

1. Press the SET, RADIO and START buttons simultaneously for 3 seconds, all the LEDs go out
2. Press the SET button for 1 second:
 - If the red "error" LED is on lock = activated (if it is the correct setting go to point 5 if not proceed with point 3)
 - If the red "error" LED is off block = deactivated (if it is the correct setting go to point 5 otherwise go to point 4)
3. Press the START button for 1 second, the yellow "set" LED remains lit and the red "error" LED goes out. Go to step 5
4. Press the START button for 1 second, the yellow "set" LED remains on and the red "error" LED lights up
5. Press the SET and RADIO buttons simultaneously or wait 10 seconds to exit the procedure: the LEDs return to the normal operating configuration

 **If the command lock is activated, any device connected to the "start" and "ped" contacts will not be detected by the control unit. When these contacts are closed, the green "start" LED will emit brief flashes.**

13. OTHER FUNCTIONS

 **To interrupt the following programming sequences at any time, press the SET and RADIO buttons simultaneously or wait 10 seconds.**

13.1 - ACTIVATING/DEACTIVATING THE CONTROL UNIT PROTECTION DEVICE

Default = control unit protection device not active.

 **This programming sequence allows for locking all control unit programming sequences and the settings adjustable through the dip-switches. To perform a new programming sequence or make a dip-switch/trimmer modification effective, the protection must be deactivated.**

1. Press the SET, RADIO and START buttons simultaneously for 3 seconds, all the LEDs go out
2. - If the yellow "set", red "radio" and green "start" LEDs remain lit: central block = activated (if it is the correct setting go to point 5 if not proceed with point 3)
 - If the yellow "set", red "radio" and green "start" LEDs are off: central block = deactivated (if it is the correct setting, go to point 5 if not, proceed to point 3)
3. Press the START and RADIO buttons simultaneously for 2 seconds: the yellow "set", red "radio" and green "start" LEDs go out. Go to step 5
4. Press the START and RADIO buttons simultaneously for 2 seconds the yellow "set", red "radio" and green "start" LEDs light up
5. Press the SET and RADIO buttons simultaneously or wait 10 seconds to exit the procedure: the LEDs return to the normal operating configuration

13.2 - RESET THE CONTROL UNIT'S DEFAULT PARAMETERS

 **This procedure allows for restoring the control unit's parameters to their default values. The procedure leaves the memorised radio transmitters unaltered. To reset the radio memory as well, see Paragraph 7.3.**

1. Press the **START** button for 8 seconds or until all leds are flashing: all led flash
2. Release **START** button
3. Press **START** button for 3 seconds: all led light up in series
4. Reset is now completed: the **ERROR** led flashes 3 times continuously
5. A new programming of the gate travel is required

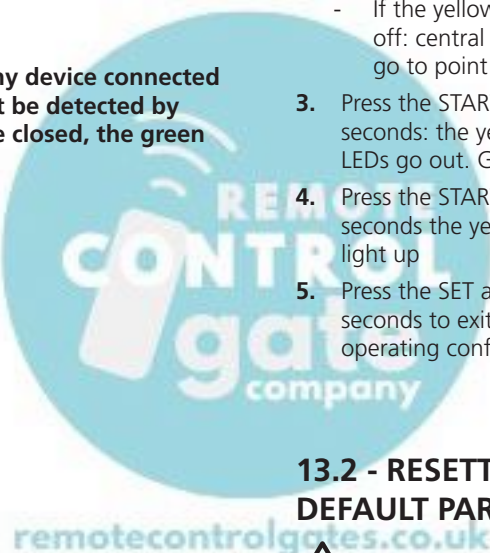

14. F.A.Q

Problem	Symptoms / Causes	Solution
The control unit LEDs are turned off	Mains power shortage	Check for the presence of input mains voltage - see Paragraph 6
	The fuses are damaged. Before replacing them, disconnect the mains electricity and verify that there are no short-circuits in the connections	Replace the fuses (see Paragraph 2.3). If the fuses get damaged again, before replacing them disconnect all the cables and verify the integrity of the PCB
The control unit does not enter the programming sequence	When the button for accessing a programming sequence is pressed, all the LEDs flash. The control unit protection has been activated	Deactivate the protection - see Paragraph 13.1.
The control unit completes the programming sequence, but does not respond to commands in the standard operating mode	Problems with the safety devices, once the programming sequence is completed, the green stop and/or photo LEDs are off	Check that the "PHO1", "PHO2" and "STOP" contacts are closed
	Photo-test of safety devices failed. After a command is pressed for a few seconds, the red "error" LED turns on	Deactivate the photo-test - see Paragraph 11.1.
The control unit causes the automation to start, but the latter does not cover the full path	Obstacle detection problems. If during the manoeuvre the control unit detects power draw peaks, it goes into obstacle present mode.	First of all, verify that the system's works in the manual mode. There must not be any points in which the gate leaf tends to stop. Raise the "OBS" trimmer by turning it clockwise (see Paragraph 3.2). If insufficient, increase the "POWER" trimmer setting and reprogram the stroke. If the problem occurs at the final stage of the path, it may be resolved by eliminating or minimising the slowdown points (see Paragraph 8.3)
	Intervention of the safety devices. Check that the green "photo" and "stop" LEDs remain lit throughout the entire manoeuvre. If there are multiple photocell pairs, these may signal false obstacles	Try bridging the "PHO1", "PHO2" and "STOP" contacts to verify whether the problem can be resolved. Otherwise, connect the photocells with alternating receivers
The transmitter does not function	When the programming sequence mentioned in Paragraph 7.1 is completed, the red "radio" LED does not flash	Verify the transmitter's compatibility: the code must be V2. If the transmitter's LED does not light up clearly, replace the battery
The transmitter has little range	The transmitter's range varies in relation to the environmental conditions	Replace the transmitter's battery. Should this not be sufficient, the control unit is configured for connecting external antennas.
The control unit does not slow down the gate	If the "Power" trimmer is too high, the control unit in the space set by default through the gate path programming procedure is unable to detect the change of speed	Reduce the setting of the POWER trimmer and reprogram the stroke; if this is not sufficient, program the deceleration points (par. 5.3) and set a longer deceleration zone.
The control unit functions correctly, but does not accept wired start and pedestrian commands	When the start or ped contacts are closed, the green "start" LED emits brief flashes. The command lock has been activated	Deactivate the pedestrian and start block. See paragraph 12.2
The control unit does not make the dip-switch or trimmer modifications effective	Once the dip-switch or trimmer positions have been modified, the control unit does not make the modifications effective. The control unit protection has been activated	Deactivate the control unit lock. See Paragraph 13.1
	Once the "power" trimmer, dip-switch 1-2 "motor" or dip-switch 8 "func" positions have been modified, no resulting effects appear on the system	To make the "power" trimmer or dip-switch 1-2 "motor" modifications effective, the basic or advanced path programming must be redone. Should this not be possible, the control unit lock has been activated. See Paragraph 13.1

15 - TESTING AND START-UP

In implementing the automation device, these are the most important steps for guaranteeing maximum safety.

V2 recommends the application of the following technical standards:

- EN 12445 (Safety in the use of automated closures, test methods)
- EN 12453 (Safety in the use of automated closures, requirements)
- EN 60204-1 (Safety of Machinery, electrical equipment of machines, part 1: general principles)

In particular, with reference to the table in the section "PRELIMINARY CHECKS and IDENTIFICATION OF THE TYPE OF USE" in the majority of cases, it will be necessary to measure the impact force, in accordance with the provisions of EN 12445.

Adjusting the operating force is possible by programming the electronic circuit board, and the impact force profile should be measured using an appropriate device (itself also certified and subjected to annual calibration) capable of tracing the force-time graph.

The result should be in compliance with the following maximum values:

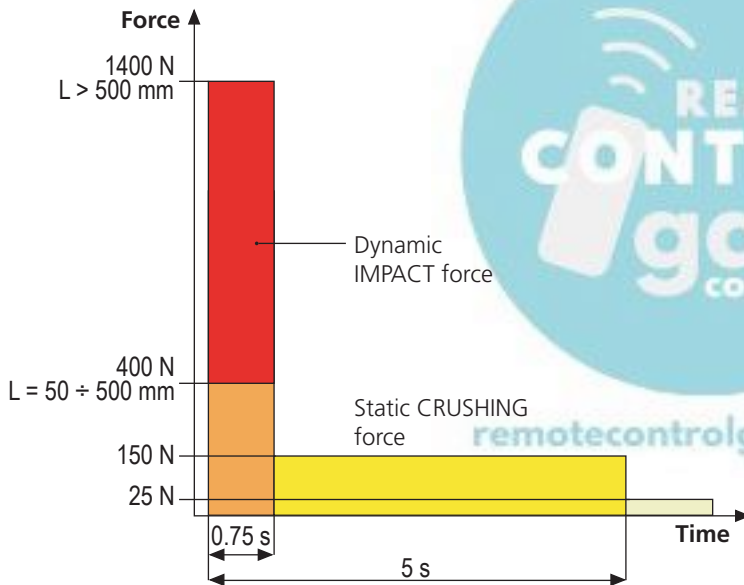

16 - MAINTENANCE

Maintenance should be performed in full compliance with the safety instructions described in this manual and in accordance with current legal and regulatory provisions.

The recommended interval between each maintenance operation is six months, the checks involved should at least relate to:

- the perfect efficiency of all warning devices
- the perfect efficiency of all safety devices
- measurement of the gate operating forces
- the lubrication of mechanical parts on the automation device (where necessary)
- the state of wear of the mechanical parts on the automation device
- the state of wear of the electrical cables on the electromechanical actuators

The result of each check should be recorded in a gate maintenance log.



17 - DISPOSAL OF THE PRODUCT

As for the installation operations, even at the end of this product's life span, the dismantling operations must be carried out by qualified experts.

This product is made up of various types of materials: some can be recycled while others need to be disposed of. Find out about the recycling or disposal systems envisaged by your local regulations for this product category.

Important! – Parts of the product could contain pollutants or hazardous substances which, if released into the environment, could cause harmful effects to the environment itself as well as to human health.

As indicated by the symbol opposite, throwing away this product as domestic waste is strictly forbidden. So dispose of it as differentiated waste, in accordance with your local regulations, or return the product to the retailer when you purchase a new equivalent product.

Important! – the local applicable regulations may envisage heavy sanctions in the event of illegal disposal of this product.

AUTOMATION DEVICE USERS MANUAL

AUTOMATION DEVICE USER INFORMATION

An automation system is a great convenience, in addition to a valid security system, and with just a little, simple care, it is made to last for years.

Even if your automation device meets all the safety standards, this does not exclude the presence of residual risk, i.e. the possibility that hazardous situations may be created, usually due to irresponsible or even improper use, and for this reason we wish to offer some advice regarding the behaviour to be adopted in order to avoid problems:

Prior to using the automation device for the first time, ask the installer to explain the sources of residual risk to you, and take some time to read the instruction manual and user information delivered by the installer.

Keep the manual for any future doubts and give it to any new owners of the device.

Your automation device is a machine that faithfully follows your commands; irresponsible and improper use can make it become hazardous: do not start movement of the device if there are people, animals or objects within its radius of action.

Children: installed in accordance with technical regulations, an automation system guarantees a high level of safety. However, it is prudent to prevent children from playing near the automation device and to avoid unintentional use; never leave the remote control within the reach of children: it is not a toy!

Anomalies: as soon as the automation device shows any anomalous behaviour, remove the electricity supply and perform manual unblocking. Do not attempt any repairs yourself, but ask your installer: in the meantime, the system can operate as a non-automated device.

Maintenance: as with all machinery, your automation devices requires periodic maintenance so that it may continue to work for as long as possible, and in complete safety. Agree a periodic maintenance plan with your installer; V2 SpA recommends a maintenance plan to be performed every 6 months for normal domestic use, but this period may vary depending on the intensity of use. Any inspection, maintenance or repairs should only be performed by qualified personnel. Even if you think you know how, do not modify the system and the automation device programming and adjustment parameters: your installer is responsible for this. Final testing, periodic maintenance and any repairs should be documented by those performing the operations, and the documents held by the system owner.

Disposal: on completion of the device's operating life, ensure that disposal is performed by qualified personnel and that the materials are recycled or disposed of in accordance with valid local regulations.

Important: If your device is fitted with a radio control, the function of which appears to deteriorate over time, or has even ceased to function, this might simply depend on the batteries being run down (depending on the type, this may be from several months to up to two/three years). Before contacting your installer, try replacing the battery with the battery from another, working transmitter: if this was the cause of the problem, then simply replace the battery with another of the same type.

Are you satisfied? Should you wish to add another automation device to your home, contact the same installer and ask for a V2 SpA product: we guarantee you the most advanced products on the market and maximum compatibility with existing automation devices. Thank you for having read these recommendations, and for any present or future needs, we ask you to contact your installer in full confidence.

MOTOR OVERRIDING SYSTEM

⚠ ATTENTION: before operating the manual release disconnect the power. The motor is anyway disconnected during the release, thanks to the presence of a safety micro-switch.

Manual control has been thought for manual opening of the gate in case of power-cut or motor breakdown.

1. Operate the manual release moving back the key hole cover.
2. Insert the key in the cylinder lock and turn it of 90° clockwise direction.
3. Pull the lever till it is perpendicular to the gear-motor.

Automation restore:

1. Bring back the lever in the original position.
2. Insert the key in the cylinder lock and turn it of 90° anticlockwise direction

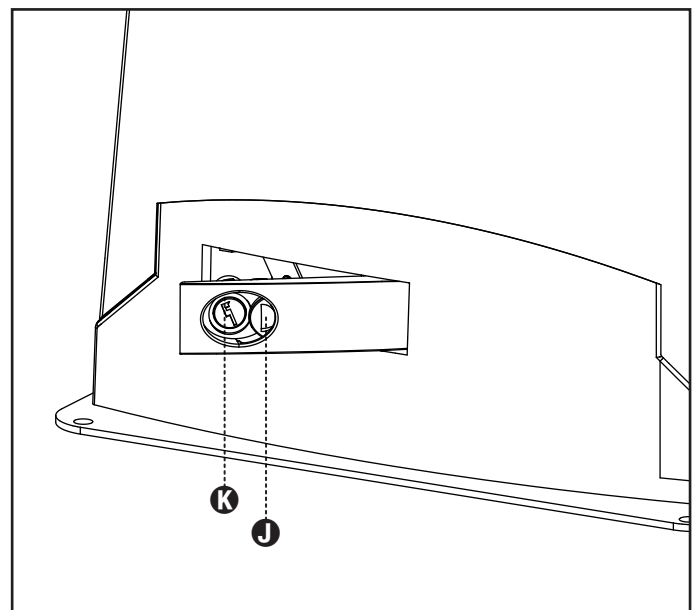



remotecontrolgates.co.uk